



**MANUFACTURED BY:**  
**Backyard Discovery**  
 3305 Airport Drive, Pittsburg, KS 66762  
 800-856-4445

Basepoint Business Centre: Rivermead Drive, Westlea, Swindon SN5 7EX Phone: 0800-118-2476  
 J.P. Coenstraat 7, The Bridge, The Hague, 2595 WP, Netherlands Phone: 0800-567-8990

# MYSTIC TOWER

## Swing Set Model # 2300255

The assembly manual must be retained since it contains important information



**WARNING**  
**Adult Assembly Required.**  
 Not suitable for children under 36 months due to small parts.  
**FOR DOMESTIC USE ONLY. INTENDED FOR OUTDOOR USE.**

CAN ICES-003 (B)/NMB-003(B)



**Please visit [www.backyarddiscovery.com](http://www.backyarddiscovery.com)**

For the most up to date assembly manual, to register your set, or to order replacement parts  
*Para obtener instrucciones en español, visite [www.backyarddiscovery.com](http://www.backyarddiscovery.com)*



**EASY STEP-BY-STEP**  
**3D INTERACTIVE INSTRUCTIONS**  
 DOWNLOAD THE FREE APP



Made in China  
 INS-2300255-A-MYSTIC TOWER-ENG 08/04/23

# Owner's Manual - Basic Setup Dimensions & Assembly Notes

Place the set on level ground, not less than 6'-7" [2 m] from any structure or obstruction such as a fence, garage, house, overhanging branches, laundry lines, or electrical wires.

- While assembling unit, take time before and after each phase to make sure fort is level. If fort is not level, assembly will be difficult and improper assembly may result. Extra care must be taken to insure the fort is square.
- The safe play area refers to a zone extending 6'-7" (2 m) beyond the play product on all sides, including the space above the play product.

## SAFE PLAY AREA DIAGRAM

### Ground Dimensions

16'-3 1/4" [5.0 m] x 12'-7 3/4" [3.9 m] x 12'-11" [3.9 m]

### Safe Play Area

29'-5 1/4" [9.0 m] x 25'-9 3/4" [7.9 m] x 19'-6" [5.9 m]

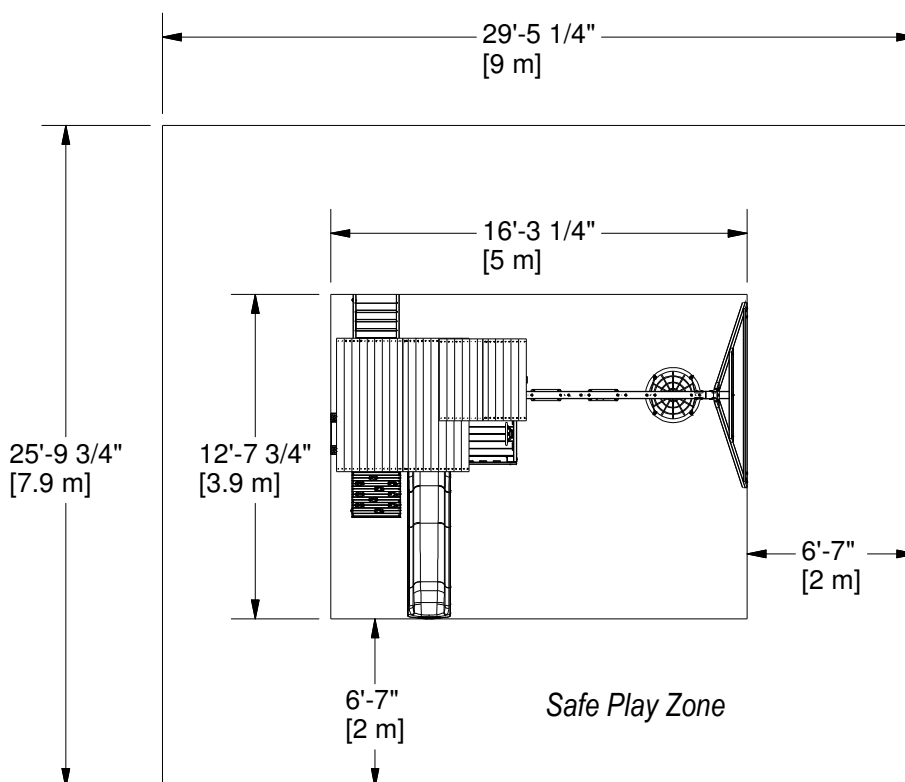

**SAFE PLAY HEIGHT: 19'-6" [5.9 m]**  
**MAXIMUM FALL HEIGHT: 6'-8 1/4" [2.0 m]**

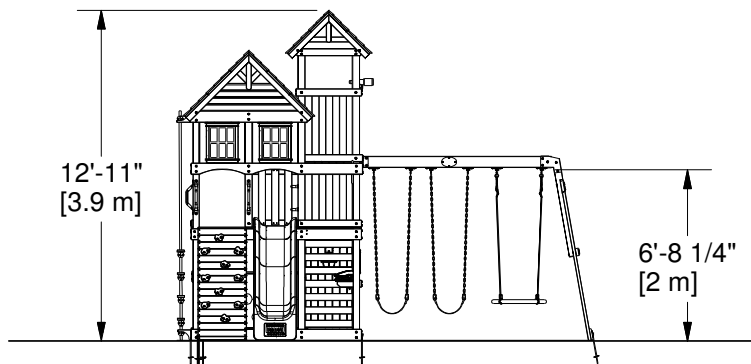

### General Information:

Your set has been designed and engineered for children only and for residential use only.  
 A maximum of 150 lbs. per child is recommended for play activities designed for individual use.  
 A maximum of 120 lbs. per child is recommended for play activities designed for multiple child use.  
 A maximum of 9 children is recommended for this swing set.

# Owner's Manual - Parts Identification

## Wood Components (Not to Scale)



**A50 SWING BEAM - W4L17936**  
(x1) 3 3/8"x5 1/4"x89 1/2" (86x134x2274)

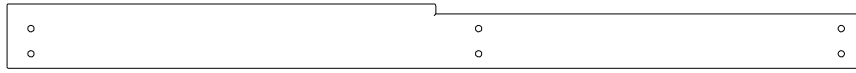

**AD01 WALL RAIL - W4L17756**  
(x1) 1"x4"x53 5/8" (24x102x1363)

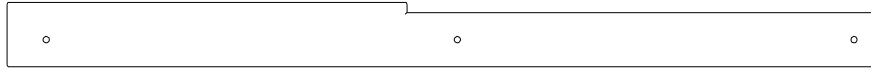

**AD02 WALL RAIL - W4L17743**  
(x1) 1"x4"x54 5/8" (24x102x1388)



**B01 POST - W4L17692**  
(x1) 3"x3"x52 3/8" (76x76x1330)



**B02 POST - W4L17693**  
(x1) 3"x3"x52 3/8" (76x76x1330)

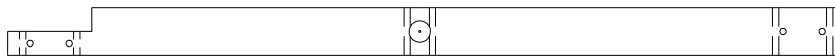

**B03 POST - W4L17694**  
(x1) 3"x3"x52 3/8" (76x76x1330)

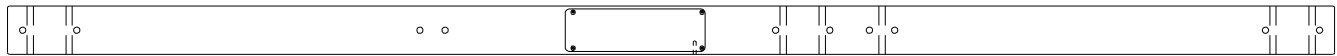

**B04 W2A03754 - POST**  
(x1) 3"x3"x83" (76x76x2108)



**B05 POST - W4L17696**  
(x1) 3"x3"x60 3/8" (76x76x1532)

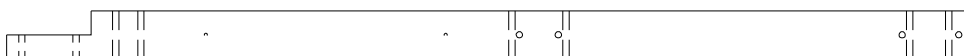

**B06 POST - W4L17697**  
(x1) 3"x3"x60 3/8" (76x76x1532)

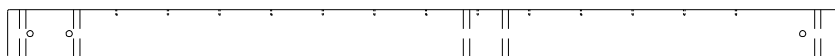

**B07 POST - W4L17700**  
(x1) 3"x3"x52 3/8" (76x76x1330)



**B08 POST - W4L17720**  
(x1) 3"x3"x89 1/2" (76x76x2273)

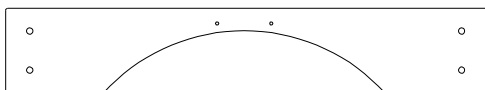

**D01 TUNNEL RAIL - W4L17725**  
(x1) 1 3/8"x5 1/4"x30 1/4" (36x134x767)

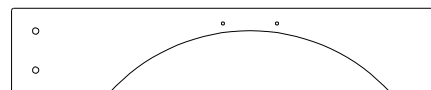

**D02 TUNNEL RAIL - W4L17726**  
(x1) 1 3/8"x5 1/4"x26 3/4" (36x134x681)

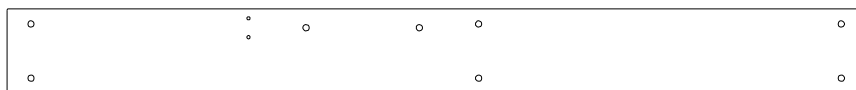

**D03 MID RAIL - W4L17713**  
(x1) 1 3/8"x5 1/4"x53 5/8" (36x134x1363)



**D04 TOP RAIL - W4L17763**  
(x1) 1 3/8"x5 1/4"x53 5/8" (36x134x1363)

# Owner's Manual - Parts Identification

## Wood Components (Not to Scale)

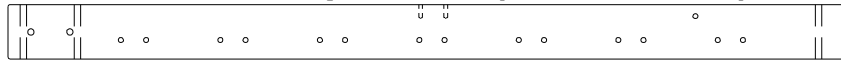

**E01 POST - W4L17702**  
(x1) 1 3/8"x3 3/8"x52 3/8" (36x86x1330)



**E02 POST - W4L17707**  
(x1) 1 3/8"x3 3/8"x52 3/8" (36x86x1330)



**E03 POST - W4L17712**  
(x1) 1 3/8"x3 3/8"x52 3/8" (36x86x1330)

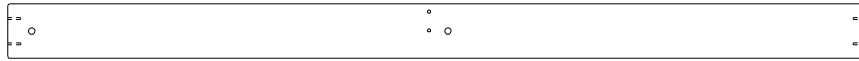

**E04 FLOOR JOIST - W4L17722**  
(x1) 1 3/8"x3 3/8"x53 5/8" (36x86x1363)



**E05 FLOOR JOIST - W4L17723**  
(x2) 1 3/8"x3 3/8"x53 5/8" (36x86x1363)



**E06 ANGLE BRACE - W4L17727**  
(x4) 1 7/16"x3 3/8"x13 3/4" (36x86x350)

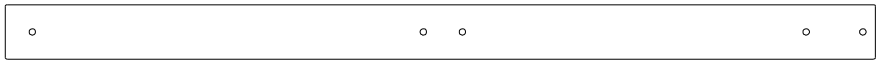

**E07 POST - W4L17734**  
(x1) 1 3/8"x3 3/8"x54 3/8" (36x86x1382)



**E08 POST - W4L17735**  
(x1) 1 3/8"x3 3/8"x52 3/8" (36x86x1330)

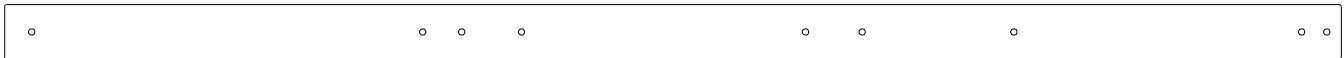

**E09 POST - W4L17739**  
(x1) 1 3/8"x3 3/8"x83 5/8" (36x86x2123)



**E10 WALL RAIL - W4L17757**  
(x1) 1 3/8"x3 3/8"x30 1/4" (36x86x767)

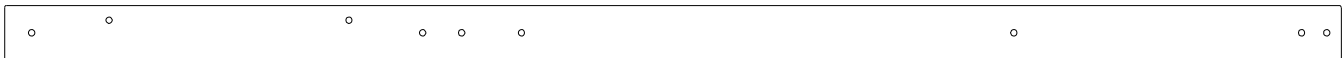

**E11 POST - W4L17753**  
(x1) 1 3/8"x3 3/8"x83 5/8" (36x86x2123)



**E12 POST - W4L17768**  
(x1) 1 3/8"x3 3/8"x83 5/8" (36x86x2123)



**E72 ROCKWALL RAIL - W4L17929**  
(x2) 1 3/8"x3 3/8"x57 3/8" (36x86x1457)



**E74 LEFT UPRIGHT - W4L17924**  
(x1) 1 3/8"x3 3/8"x57 1/4" (36x86x1453)



**E75 RIGHT UPRIGHT - W4L17925**  
(x1) 1 3/8"x3 3/8"x57 1/4" (36x86x1453)

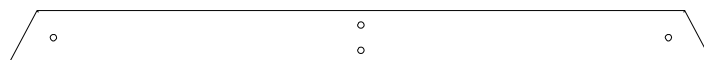

**E79 END SUPPORT - W4L17939**  
(x1) 1 1/2"x3 1/2"x44" (36x86x1120)



**E80 ANGLE BRACE - W4L17938**  
(x2) 1 3/8"x3 3/8"x87 1/8" (36x86x2212)



# Owner's Manual - Parts Identification

## Wood Components (Not to Scale)



**G01 GROUND BOARD - W4L17698**  
(x1) 1"x5 1/4"x80" (24x134x2032)



**G02 GROUND BOARD - W4L17699**  
(x1) 1"x5 1/4"x53 5/8" (24x134x1363)



**G03 GROUND BOARD - W4L17701**  
(x1) 1"x5 1/4"x29 1/2" (24x134x748)



**G04 FLOOR RAIL - W4L17703**  
(x1) 1"x5 1/4"x80" (24x134x2032)



**G05 FLOOR RAIL - W4L17704**  
(x1) 1"x5 1/4"x53 5/8" (24x134x1363)



**G06 FLOOR RAIL - W4L17705**  
(x1) 1"x5 1/4"x53 5/8" (24x134x1363)



**G07 FLOOR RAIL - W4L17706**  
(x1) 1"x5 1/4"x80" (24x134x2032)

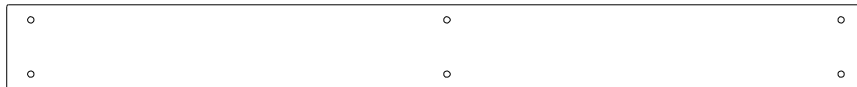

**G08 GROUND BOARD - W4L17708**  
(x1) 1"x5 1/4"x53 5/8" (24x134x1363)



**G09 GROUND BOARD - W4L17710**  
(x1) 1"x5 1/4"x52 5/8" (24x134x1336)



**G10 GROUND BOARD - W4L17711**  
(x1) 1"x5 1/4"x78 1/8" (24x134x1984)

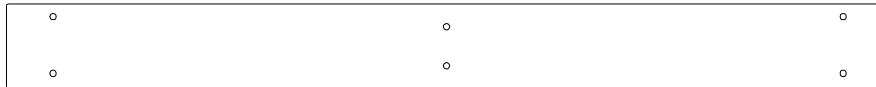

**G11 WALL RAIL - W4L17737**  
(x1) 1"x5 1/4"x55" (24x134x1396)



**G12 GROUND BOARD - W4L17715**  
(x1) 1"x5 1/4"x25 7/8" (24x134x657)

# Owner's Manual - Parts Identification

## Wood Components (Not to Scale)

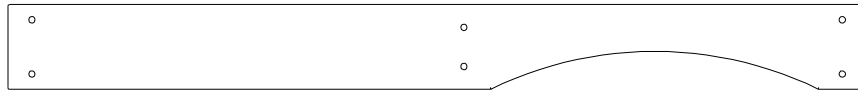

**G13 MID RAIL - W4L17716**  
(x1) 1"x5 1/4"x53 5/8" (24x134x1363)

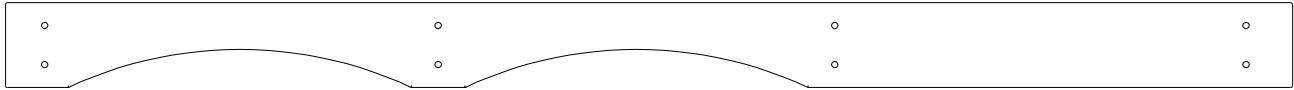

**G14 MID RAIL - W4L17717**  
(x1) 1"x5 1/4"x80 1/2" (24x134x2044)



**G15 MID RAIL - W4L17718**  
(x1) 1"x5 1/4"x80 1/2" (24x134x2044)

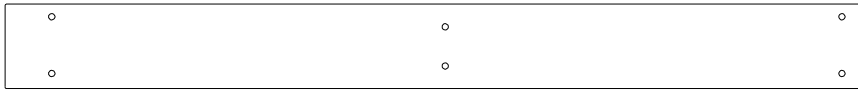

**G16 WALL RAIL - W4L17738**  
(x1) 1"x5 1/4"x54" (24x134x1372)

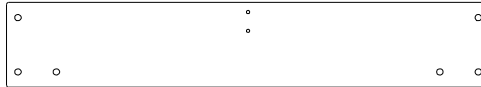

**G17 FLOOR RAIL - W4L17744**  
(x1) 1"x5 1/4"x30 1/4" (24x134x767)



**G18 FLOOR SUPPORT - W4L17754**  
(x1) 1"x5 1/4"x29 7/8" (24x134x758)



**G19 SUPPORT BOARD - W4L17966**  
(x1) 1"x5 1/4"x48 1/4" (24x134x1226)



**G50 GROUND BOARD - W4L17940**  
(x1) 1"x5 1/4"x86 11/16" (24x134x2202)

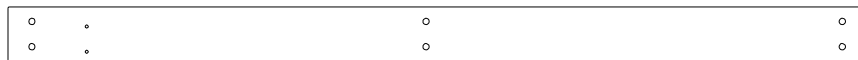

**H01 LOWER RAIL - W4L17719**  
(x1) 1"x3 3/8"x53 5/8" (24x86x1363)



**H02 LADDER RUNG - W4L17724**  
(x7) 1"x3 3/8"x26 1/8" (24x86x662)

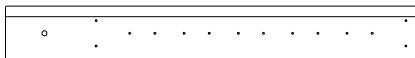

**H03 DOOR RAIL - W4L17764**  
(x1) 1"x3 3/8"x26 1/4" (24x86x666)



**H04 UPRIGHT - W4L17732**  
(x1) 1"x3 3/8"x29 3/4" (24x86x756)



**H05 PICKET RAIL - W4L17733**  
(x1) 1"x3 3/8"x30 1/4" (24x86x767)

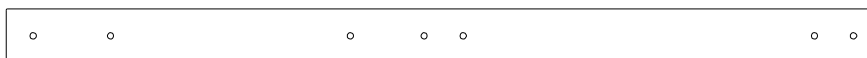

**H06 UPRIGHT - W4L17736**  
(x2) 1"x3 3/8"x54 3/8" (24x86x1382)

# Owner's Manual - Parts Identification

## Wood Components (Not to Scale)



**H07 WALL RAIL - W4L17740**  
(x1) 1"x3 3/8"x30 3/8" (24x86x770)



**H08 WALL RAIL - W4L17741**  
(x1) 1"x3 3/8"x30 3/8" (24x86x770)



**H09 WALL RAIL - W4L17742**  
(x1) 1"x3 3/8"x30 1/4" (24x86x767)



**H10 FLOOR SUPPORT - W4L17758**  
(x3) 15/16"x3 3/8"x2 5/8" (24x86x66)



**H11 STEP PICKET - W4L17745**  
(x2) 1"x3 3/8"x27 3/8" (24x86x695)



**H12 FLOOR JOIST - W4L17979**  
(x1) 1"x3 3/8"x24 1/8" (24x86x612)



**H13 WALL RAIL - W4L17755**  
(x1) 1"x3 3/8"x29 7/8" (24x86x758)



**H14 WALL RAIL - W4L17765**  
(x1) 1"x3 3/8"x30 3/4" (24x86x782)



**H15 WALL RAIL - W4L17766**  
(x1) 1"x3 3/8"x30 3/4" (24x86x782)



**H16 WALL RAIL - W4L17767**  
(x1) 1"x3 3/8"x30 1/4" (24x86x767)



**H17 WALL RAIL - W4L17769**  
(x1) 1"x3 3/8"x30 1/4" (24x86x767)



**H18 TABLE SUPPORT - W4L17980**  
(x1) 1"x2 3/4"x10 1/2" (24x70x268)



**H19 TABLE SUPPORT - W4L17981**  
(x1) 1"x2 3/4"x10 1/2" (24x70x268)



**H20 DOOR RAIL - W4L17984**  
(x2) 1"x3 3/8"x21 3/4" (24x86x552)



**H22 LADDER RUNG - W4L17915**  
(x4) 1"x3 3/8"x18 1/8" (24x86x460)

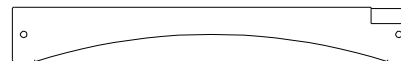

**H23 WALL RAIL - W4L17775**  
(x1) 1"x3 3/8"x24 7/8" (24x86x632)



**H24 ROOF RAFTER - W4L17774**  
(x4) 1"x3 3/8"x42 5/8" (24x86x1083)



**H25 ROOF RAFTER - W4L17918**  
(x4) 1"x3 3/8"x27 1/2" (24x86x700)



**H77 ATTACHMENT BOARD - W4L17931**  
(x1) 1"x3 3/8"x22 7/8" (24x86x580)



**H81 LADDER RUNG - W4L17927**  
(x4) 1"x3 3/8"x19 3/4" (24x86x502)



**H102 ATTACHMENT BOARD - W4L17928**  
(x1) 1"x3 3/8"x21 5/8" (24x86x550)

# Owner's Manual - Parts Identification

## Wood Components (Not to Scale)



**J01 FLOOR SUPPORT - W4L17729**  
(x4) 15/16"x3"x2 3/8" (24x76x60)



**J02 FLOOR JOIST - W4L17746**  
(x1) 1"x2 3/8"x28 7/8" (24x60x734)



**J03 GABLE BOARD - W4L17978**  
(x2) 1"x2 3/8"x9 5/8" (24x60x245)



**J04 GABLE BOARD - W4L17921**  
(x2) 1"x2 3/8"x13" (24x60x330)



**J05 DOOR BOARD - W4L17987**  
(x1) 1"x2 3/8"x40 1/2" (24x60x1030)



**J06 DOOR BOARD - W4L17985**  
(x1) 1"x2 3/8"x40 1/2" (24x60x1030)



**K02 TABLE TOP - W4L17982**  
(x1) 5/8"x5 1/4"x22 3/8" (16x134x568)



**K03 TABLE TOP - W4L17983**  
(x1) 5/8"x5 1/4"x22 3/8" (16x134x568)

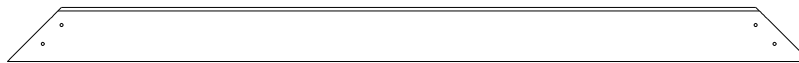

**K901 GABLE BOARD - W4L17968**  
(x2) 3/8"x3 3/8"x50 1/4" (11x86x1275)



**K902 GABLE BOARD - W4L17969**  
(x2) 3/8"x3 3/8"x43 7/8" (11x86x1113)



**K903 GABLE BOARD - W4L17970**  
(x2) 3/8"x3 3/8"x37 1/2" (11x86x951)

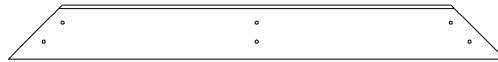

**K904 GABLE BOARD - W4L17971**  
(x2) 3/8"x3 3/8"x31 1/8" (11x86x789)

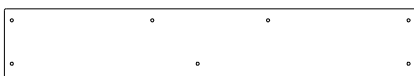

**L01 FLOOR BOARD - W4L17760**  
(x1) 5/8"x4 3/8"x25 3/4" (16x112x654)

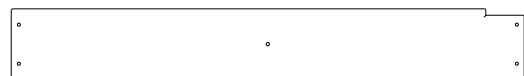

**L02 FLOOR BOARD - W4L17761**  
(x1) 5/8"x4 3/8"x32 1/8" (16x112x815)

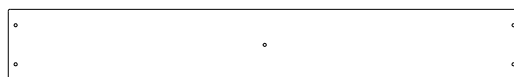

**L03 FLOOR BOARD - W4L17721**  
(x1) 5/8"x4 3/8"x32 1/8" (16x112x815)

# Owner's Manual - Parts Identification

## Wood Components (Not to Scale)



**M01 FLOOR BOARD - W4L17709**  
(x7) 5/8"x3 3/8"x80" (16x86x2032)



**M02 FLOOR BOARD - W4L17714**  
(x16) 5/8"x3 3/8"x23 7/8" (16x86x605)



**M03 FLOOR BOARD - W4L17728**  
(x7) 5/8"x3 3/8"x55" (16x86x1396)



**M04 WALL BOARD - W4L17747**  
(x3) 5/8"x3 3/8"x46 1/2" (16x86x1182)

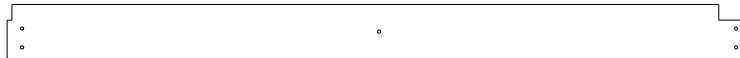

**M05 WALL BOARD - W4L17748**  
(x1) 5/8"x3 3/8"x46 1/2" (16x86x1182)

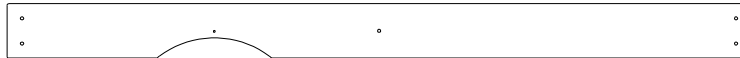

**M06 WALL BOARD - W4L17749**  
(x2) 5/8"x3 3/8"x46 1/2" (16x86x1182)



**M07 WALL BOARD - W4L17750**  
(x1) 5/8"x3 3/8"x29 1/4" (16x86x742)



**M08 WALL BOARD - W4L17751**  
(x1) 5/8"x3 3/8"x8 5/8" (16x86x219)



**M09 PICKET - W4L17752**  
(x26) 5/8"x3 3/8"x26 5/8" (16x86x675)



**M10 WALL BOARD - W4L17770**  
(x5) 5/8"x3 3/8"x23 5/8" (16x86x600)



**M11 WALL BOARD - W4L17771**  
(x6) 5/8"x3 3/8"x23 5/8" (16x86x600)



**M12 WALL BOARD - W4L17773**  
(x10) 5/8"x3 3/8"x31 3/4" (16x86x808)



**M13 WALL BOARD - W4L17941**  
(x1) 5/8"x3 3/8"x23 5/8" (16x86x600)



**M14 WALL RAIL - W4L17913**  
(x1) 5/8"x3 3/8"x30 1/4" (16x86x767)



**M15 WALL RAIL - W4L17914**  
(x1) 5/8"x3 3/8"x30 1/4" (16x86x767)



**M16 WALL RAIL - W4L17911**  
(x2) 5/8"x3 3/8"x30 1/8" (16x86x766)



**M18 DOOR BOARD - W4L17989**  
(x1) 5/8"x3 3/8"x5 1/4" (16x86x133)



**M19 DOOR BOARD - W4L17990**  
(x1) 5/8"x3 3/8"x26 5/8" (16x86x676)

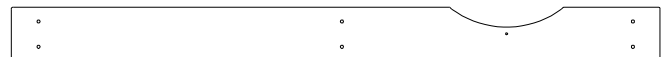

**M20 DOOR BOARD - W4L17988**  
(x2) 5/8"x3 3/8"x40 1/2" (16x86x1030)



**M21 DOOR BOARD - W4L17986**  
(x2) 5/8"x3 3/8"x40 1/2" (16x86x1030)

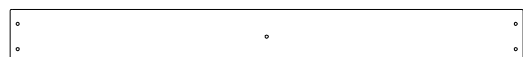

**M22 FLOOR BOARD - W4L17762**  
(x4) 5/8"x3 3/8"x32 1/8" (16x86x815)

# Owner's Manual - Parts Identification

## Wood Components (Not to Scale)



**M74 ROCK WALL BOARD - W4L17932**  
(x9) 5/8"x3 3/8"x22 7/8" (16x86x580)



**M75 ROCK WALL BOARD - W4L17933**  
(x4) 5/8"x3 3/8"x22 7/8" (16x86x580)



**M76 ROCK WALL BOARD - W4L17934**  
(x3) 5/8"x3 3/8"x22 7/8" (16x86x580)



**M103 REAR SUPPORT - W4L17926**  
(x1) 5/8"x3 3/8"x21 5/8" (16x86x550)

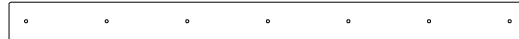

**N01 ROOF CLEAT - W4L17922**  
(x3) 5/8"x2 3/8"x32 3/8" (16x60x822)

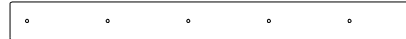

**N02 ROOF CLEAT - W4L17923**  
(x1) 5/8"x2 3/8"x25 3/8" (16x60x644)



**N03 GABLE BOARD - W4L17919**  
(x4) 5/8"x2 3/8"x9" (16x60x230)



**N04 GABLE BOARD - W4L17920**  
(x2) 5/8"x2 3/8"x25 5/8" (16x60x650)



**N73 ROCK WALL BOARD - W4L17930**  
(x1) 5/8"x1 3/4"x22 7/8" (16x45x580)

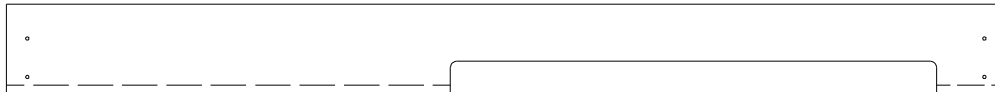

**R01 ROOF BOARD - W4L17916**  
(x1) 3/4"x5 1/2"x62 1/2" (18x140x1586)



**R02 ROOF BOARD - W4L17917**  
(x1) 3/4"x5 1/2"x62 1/2" (18x140x1586)



**SP71 SWING BEAM SUPPORT - W4L17937**  
(x1) 3 3/8"x3 3/8"x46 1/8" (86x86x1172)

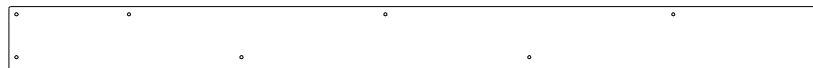

**Y01 FLOOR BOARD - W4L17730**  
(x1) 5/8"x3 7/8"x51" (16x100x1296)



**Y02 FLOOR BOARD - W4L17731**  
(x1) 5/8"x3 7/8"x72 1/8" (16x100x1832)



**Y03 FLOOR BOARD - W4L17759**  
(x1) 5/8"x4 3/8"x27 3/8" (16x111x694)



**Y04 WALL BOARD - W4L17772**  
(x12) 5/8"x3 7/8"x4 1/8" (16x98x105)



**Y78 ROCK WALL END BOARD - W4L17935**  
(x1) 5/8"x3 7/8"x22 7/8" (16x98x580)

# Owner's Manual - Parts Identification

## Wood Components (Not to Scale)



**RP1 PEAK ROOF PANEL - W2A03756**  
*(x2) 1 5/8"x13 3/8"x62 1/2" (42x341x1586)*

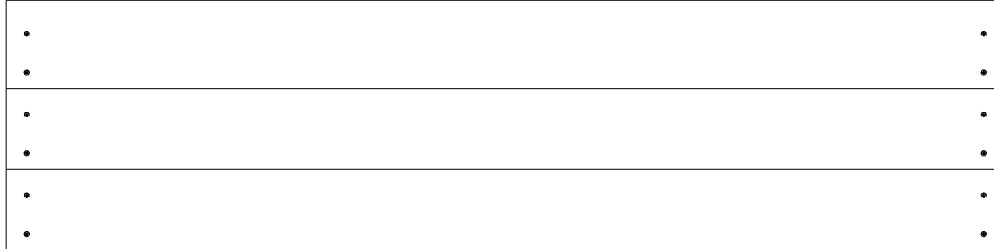

**RP2 ROOF PANEL - W2A03757**  
*(x2) 1 5/8"x15 5/8"x59" (42x396x1586)*

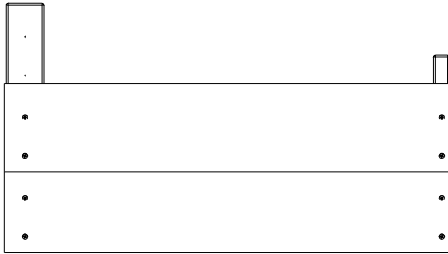

**RP3 ROOF PANEL - W2A03758**  
*(x1) 1 5/8"x15 1/2"x27 3/4" (42x395x707)*



**RP4 ROOF PANEL - W2A03759**  
*(x1) 1 5/8"x15 1/2"x27 3/4" (42x395x111)*

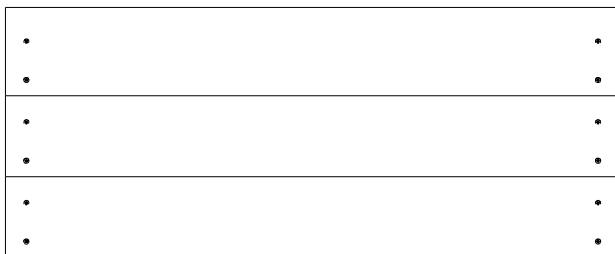

**RP5 ROOF PANEL - W2A03760**  
*(x2) 1 5/8"x15 5/8"x59" (42x396x974)*

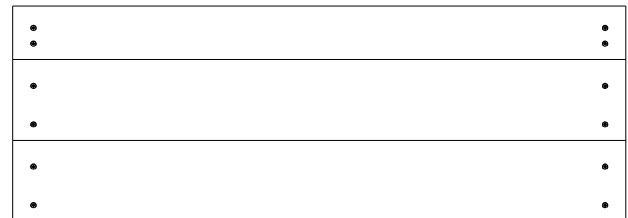

**RP6 PEAK ROOF PANEL - W2A03761**  
*(x2) 1 5/8"x13 3/8"x62 1/2" (42x341x974)*

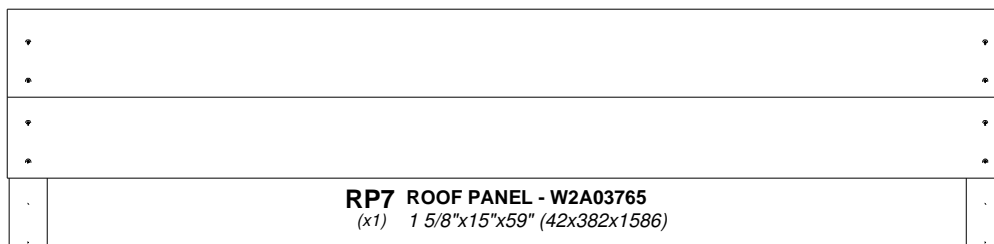

**RP7 ROOF PANEL - W2A03765**  
*(x1) 1 5/8"x15"x59" (42x382x1586)*

# Owner's Manual - Parts Identification

## Hardware Components

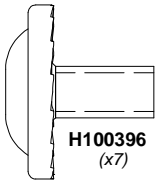

**H100396 BOLT WH BLK**  
(x7) 5/16x1/2

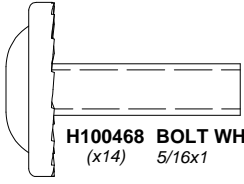

**H100468 BOLT WH BLK**  
(x14) 5/16x1

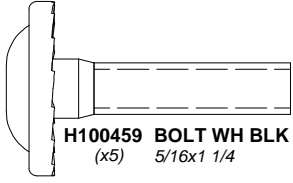

**H100459 BOLT WH BLK**  
(x5) 5/16x1 1/4

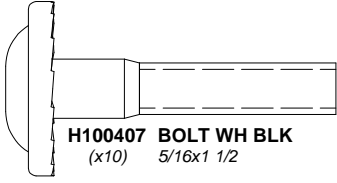

**H100407 BOLT WH BLK**  
(x10) 5/16x1 1/2

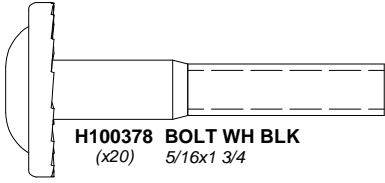

**H100378 BOLT WH BLK**  
(x20) 5/16x1 3/4

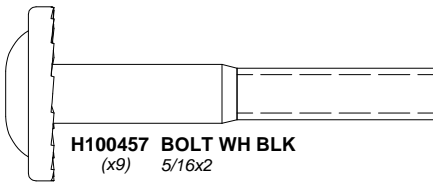

**H100457 BOLT WH BLK**  
(x9) 5/16x2

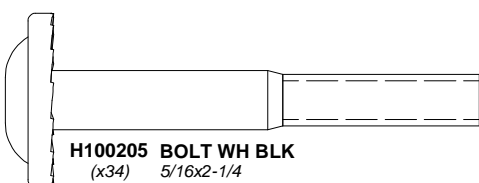

**H100205 BOLT WH BLK**  
(x34) 5/16x2-1/4

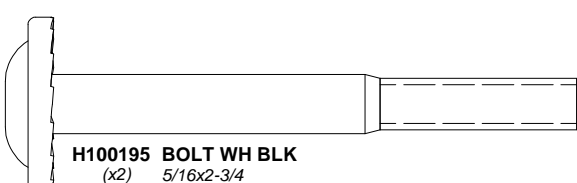

**H100195 BOLT WH BLK**  
(x2) 5/16x2-3/4

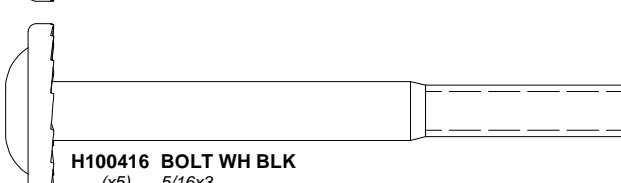

**H100416 BOLT WH BLK**  
(x5) 5/16x3



**H100114 TORX WRENCH**  
(x1) T-30



**H100480 BOLT WH BLK**  
(x15) 5/16x4 3/4

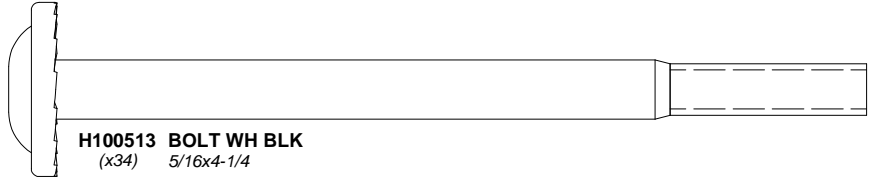

**H100513 BOLT WH BLK**  
(x34) 5/16x4-1/4

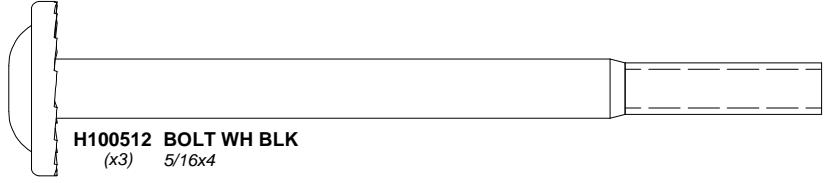

**H100512 BOLT WH BLK**  
(x3) 5/16x4

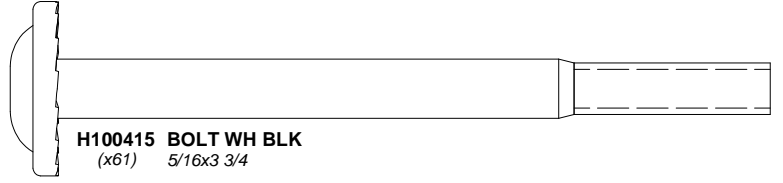

**H100415 BOLT WH BLK**  
(x61) 5/16x3 3/4

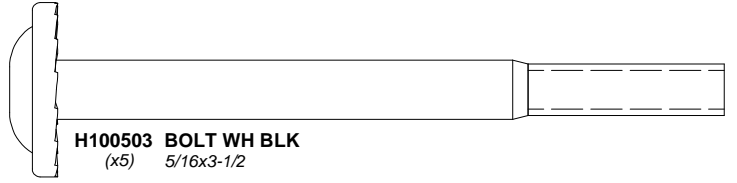

**H100503 BOLT WH BLK**  
(x5) 5/16x3-1/2

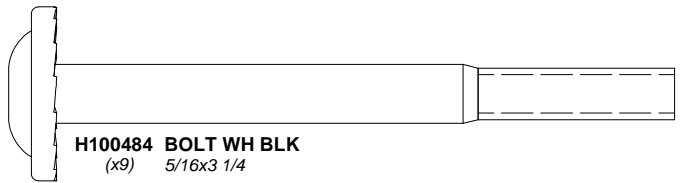

**H100484 BOLT WH BLK**  
(x9) 5/16x3 1/4

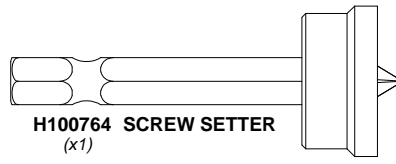

**H100764 SCREW SETTER**  
(x1)



**H100197 LAG SCREW WH BLK**  
(x3) 5/16x2 1/2

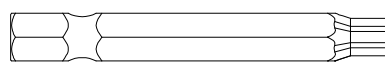

**H100147 TORX BIT**  
(x1) T-30

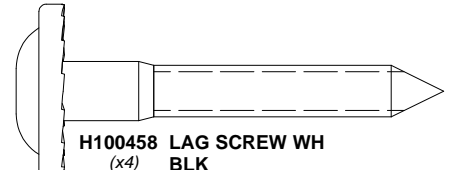

**H100458 LAG SCREW WH BLK**  
(x4) 5/16x2

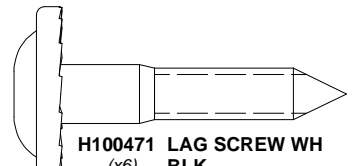

**H100471 LAG SCREW WH BLK**  
(x6) 5/16x1 1/2



**H101100 MAGNETIC DRIVER**  
(x1)



# Owner's Manual - Parts Identification

## Hardware Components

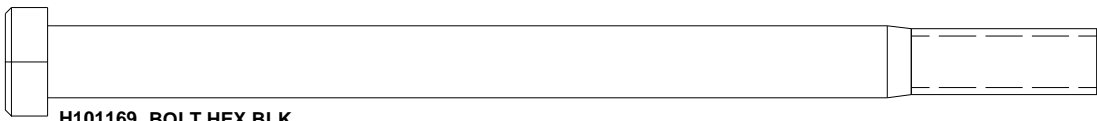

**H101169 BOLT HEX BLK**  
(x12) 3/8x5-1/2

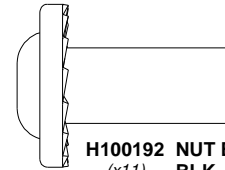

**H100192 NUT BARREL WH BLK**  
(x11) 5/16x7/8



**H100476 BOLT HEX BLK**  
(x2) 5/16x4 1/4

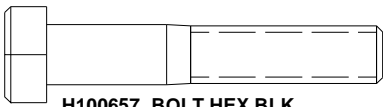

**H100657 BOLT HEX BLK**  
(x12) 5/16x1 3/4

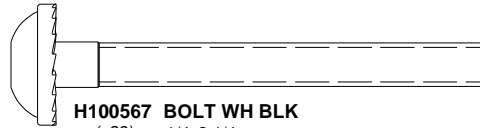

**H100567 BOLT WH BLK**  
(x29) 1/4x2 1/4

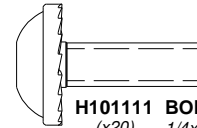

**H101111 BOLT WH BLK**  
(x20) 1/4x3/4

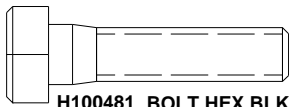

**H100481 BOLT HEX BLK**  
(x8) 5/16x1 1/4

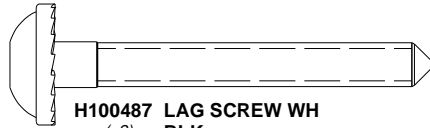

**H100487 LAG SCREW WH BLK**  
(x3) 1/4x2

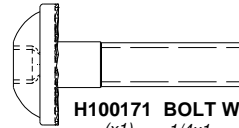

**H100171 BOLT WH BLK**  
(x1) 1/4x1

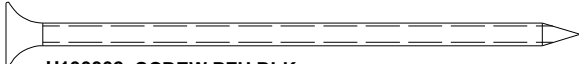

**H100362 SCREW PFH BLK**  
(x6) 8x3

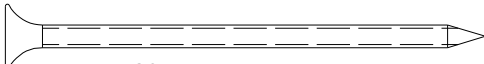

**H100201 SCREW PFH BLK**  
(x26) 8x2-1/2

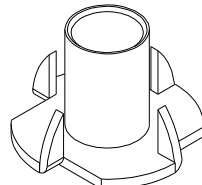

**H101168 T-NUT BLK**  
(x12) 3/8

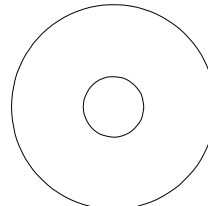

**H100478 WASHER FLAT BLK**  
(x24) 8x27

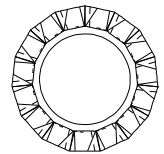

**H100199 WASHER LOCK EXT BLK**  
(x6) 12x19

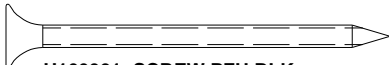

**H100391 SCREW PFH BLK**  
(x66) 8x2

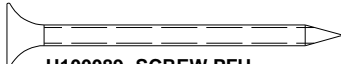

**H100089 SCREW PFH**  
(x78) 8x1 3/4

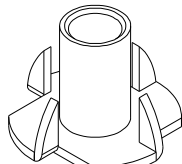

**H100379 T-NUT BLK**  
(x242) 5/16

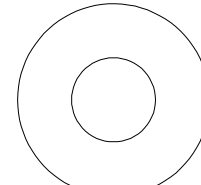

**H101167 WASHER FLAT BLK**  
(x12) 11x25

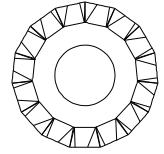

**H100198 WASHER LOCK EXT BLK**  
(x193) 8x19

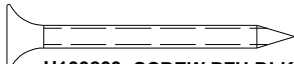

**H100200 SCREW PFH BLK**  
(x4) 8x1 1/2

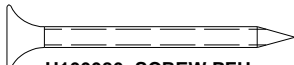

**H100086 SCREW PFH**  
(x217) 8x1 1/2

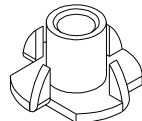

**H100398 T-NUT BLK**  
(x50) 1/4

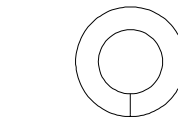

**H100477 WASHER SPLIT BLK**  
(x20) 5/16

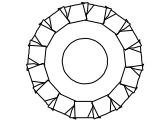

**H100405 WASHER LOCK EXT BLK**  
(x33) 6x15

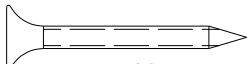

**H100387 SCREW PFH BLK**  
(x11) 8x1 1/4

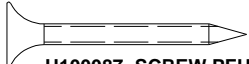

**H100087 SCREW PFH**  
(x350) 8x1 1/4

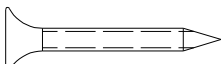

**H100380 SCREW PFH BLK**  
(x26) 8x1 1/8

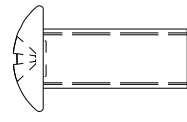

**H100831 NUT BARREL PTH BLK**  
(x4) 1/4x3/4

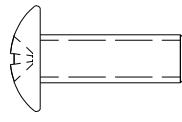

**H100832 BOLT PTH BLK (with LOCTITE)**  
(x4) 1/4x3/4

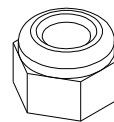

**H100479 NUT LOCK BLK**  
(x2) 5/16

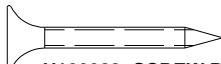

**H100088 SCREW PFH**  
(x18) 8x1 1/8

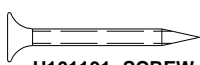

**H101191 SCREW PFH BLK**  
(x26) 6x1

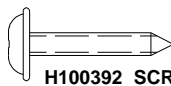

**H100392 SCREW PWH BLK**  
(x62) 8x3/4

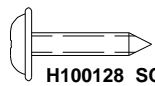

**H100128 SCREW PWH**  
(x12) 8x5/8

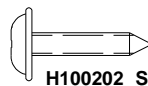

**H100202 SCREW PWH BLK**  
(x4) 8x5/8

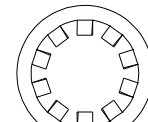

**H101166 WASHER LOCK INT BLK**  
(x12) 10x18

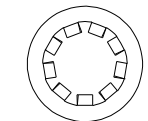

**H100473 WASHER LOCK INT BLK**  
(x20) 8x15

# Owner's Manual - Parts Identification

## Accessory Components (Not to Scale)

A6P00564 ROPE  
(x2)

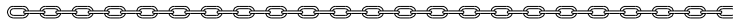

A4M02212 CHAIN BLACK  
(x4) 57"



A4M02062 HINGE 1025mm  
(x1)

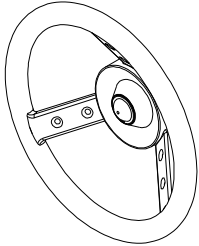

A6P00618 STEERING WHEEL  
(x1)



A6P00595 SWING SEAT  
(x2) GREY 22"



A100164 BYD ID TAG  
(x1) (LARGE) AGES 3-10

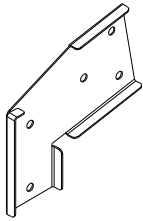

A4M00617 SWING BEAM  
(x1) EXTENSION BRACKET-LEFT

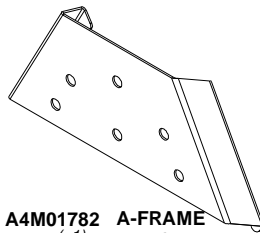

A4M01782 A-FRAME  
(x1) BRACKET

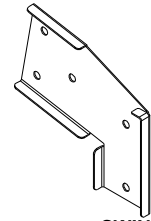

A4M00618 SWING BEAM  
(x1) EXTENSION BRACKET-RIGHT

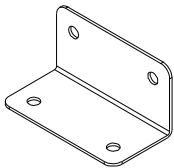

A4M00619 L BRACKET  
(x2) 66x66x127 - BLK

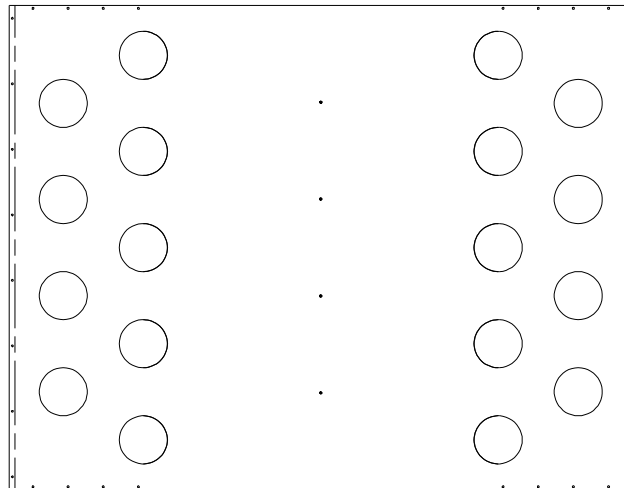

A6P00557 TUNNEL  
(x1)

**TIP:**  
PLACING THE TUNNEL OUT IN THE SUN MAKES IT EASIER TO FORM.

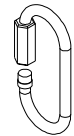

A4M00633 QUICK LINK BLK  
(x4)

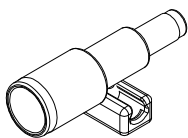

A6P00596 TELESCOPE  
(x1)

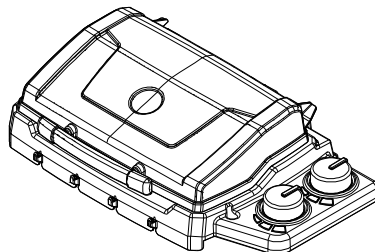

A6P00282 BBQ GRILL  
(x1)

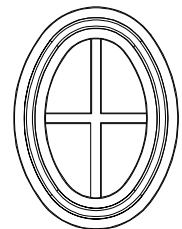

A6P00052 OVAL WINDOW  
(x2)

# Owner's Manual - Parts Identification

## Accessory Components (Not to Scale)

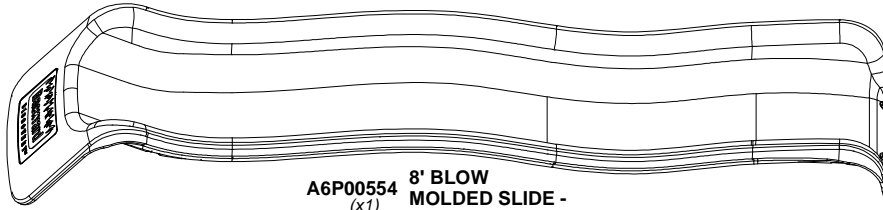

**A6P00554** 8' BLOW  
(x1) MOLDED SLIDE -  
GRAY

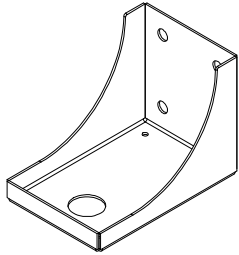

**A4M02061** ROPE LADDER  
(x4) BRACKET

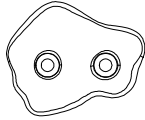

**A6P00593** GREY HC ROCK  
(x5) #2

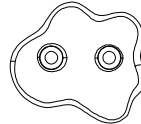

**A6P00592** GREY HC ROCK  
(x5) #1



**A4M02252** AUGER GROUND  
(x8) STAKE

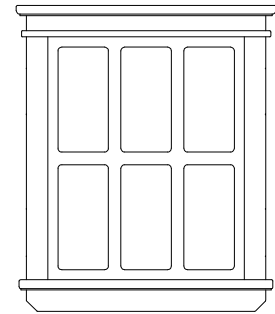

**A100321** PLASTIC  
(x3) WINDOW  
44x412x485

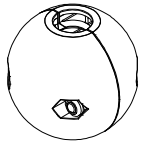

**A6P00508** ROPE CLAMP  
(x12) KIT

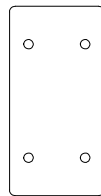

**A4M02100** GABLE CLEAT  
(x4)

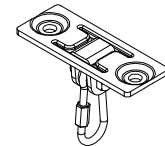

**A4M02171** SWING HANGER  
(x6)

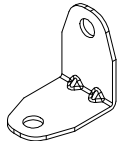

**A4M01047** L BRACKET  
(x6) 2.5x38x55x55

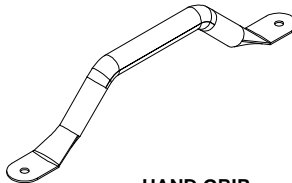

**A4M02249** HAND GRIP  
(x8) METAL GREY 381  
c/c

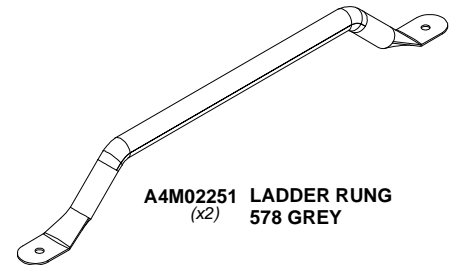

**A4M02251** LADDER RUNG  
(x2) 578 GREY

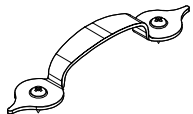

**A4M00627** DOOR HANDLE  
(x1) KIT

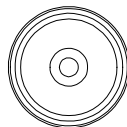

**A4M02063** MAGNETIC  
(x1) DOOR CATCH



**141154** GRILL FOOD SET - SINGLE SERVING  
(x1)



**A4M01126** 26" WEB SWING  
(x1)

# PRE-ASSEMBLY STEP 1 - SORTING PARTS

It is critical for ease of assembly that you take the time to sort and organize the wood and hardware.

---

## WOOD PARTS:

- Organize wood parts by the three-digit, alpha-numeric number stamped on each board (ex. P01).
- If there are multiple boards with the same stamped number, stack those pieces together.
- Stamps can be found on the flat surface of the boards or on the end of the boards.
- Allow yourself plenty of room - the wood pieces can take up a significant amount of space.

**NOTE: CARTONS ARE NOT ORGANIZED BY BOARD NUMBER.**

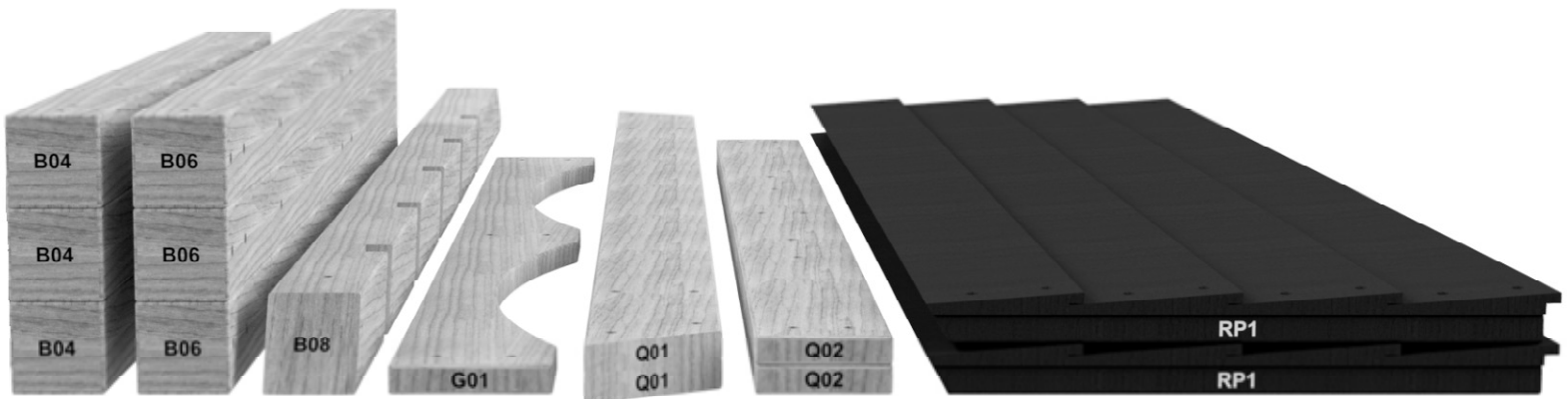

---

## HARDWARE PARTS:

- We recommend that you have a separate table to organize the hardware.
- Hardware bags are printed with a seven-digit, alpha-numeric part number.
- You can organize your hardware by part number or group by hardware type (i.e. bolts, nuts, etc.).
- During assembly you only need to reference the last four digits of the number.

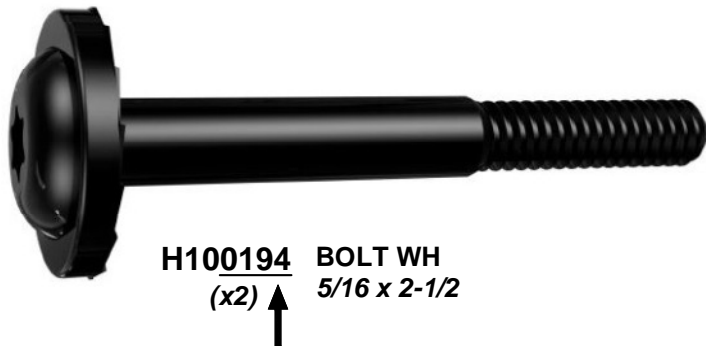

# PRE-ASSEMBLY STEP 2 - TOOLS REQUIRED



Cordless Drill or  
Electric Drill



Drill Attachments:  
Phillips Head



1/8", 3/16", 3/8" & 7/16"  
Drill Bits



Phillips Screw Driver



Open End Wrenches 1/2" & 9/16"



3/8" Drive Ratchet, 1/2" &  
9/16" STD Sockets 1/2" & 9/16" Deep  
Sockets



Claw Hammer



Rubber Mallet - Optional



Tape Measure

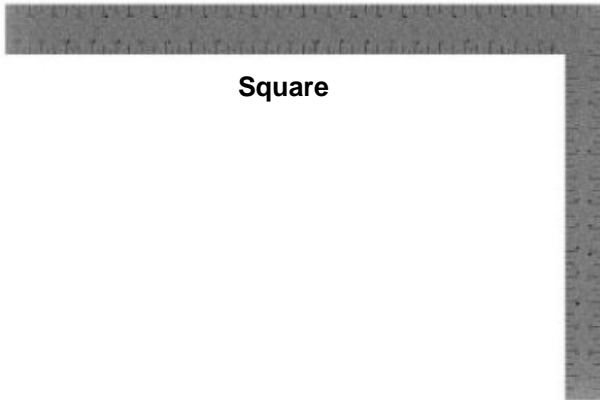

Square



Level 24"

# PRE-ASSEMBLY STEP 3 - CHOOSE YOUR ASSEMBLY METHOD

There are several types of assembly instructions available to you.

1. Printed Assembly Manual included with your set
2. BILT APP - 3D interactive instructions
3. Combination of the Printed Manual and BILT APP (Note: Step numbers can differ between the two methods)

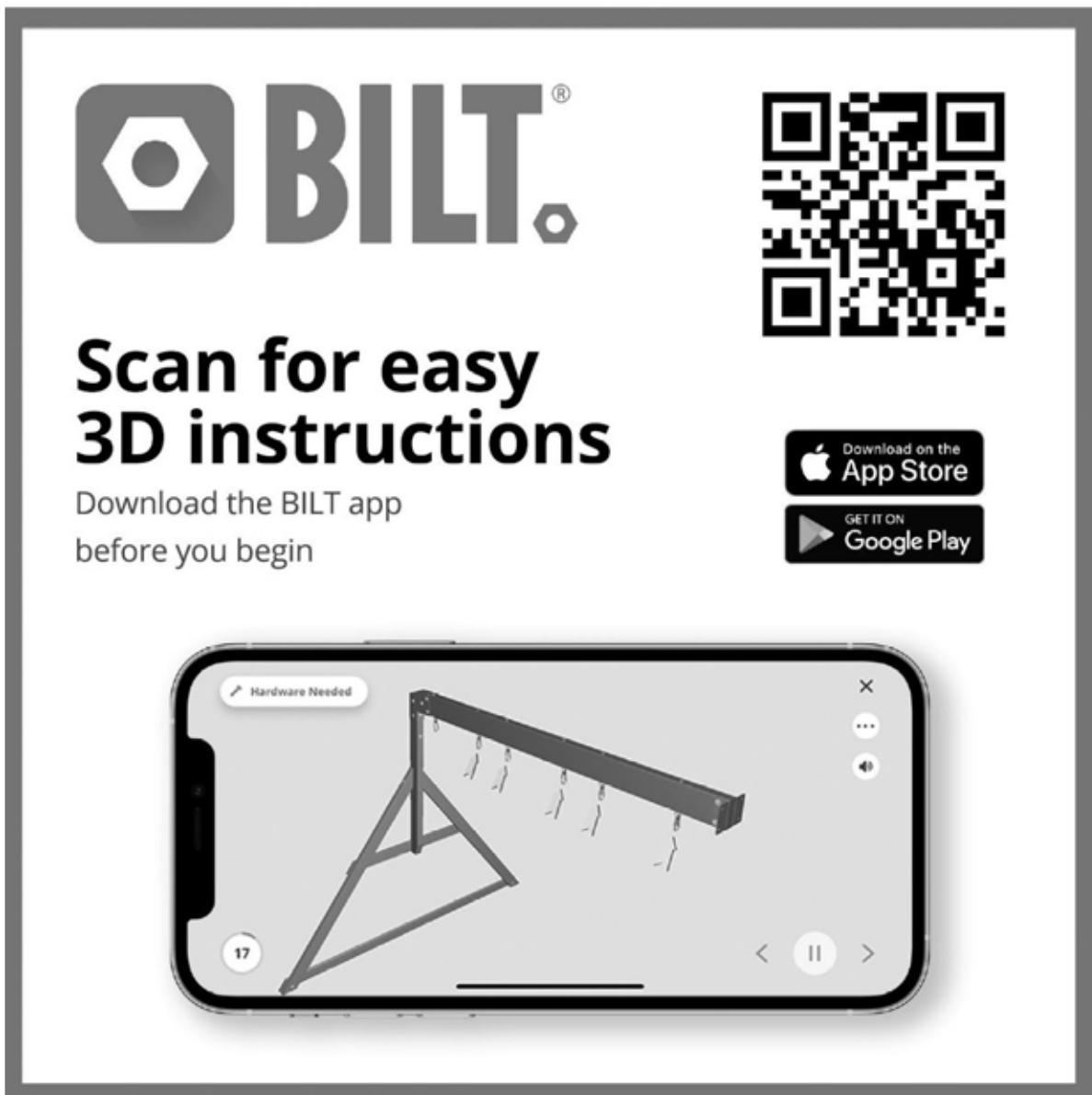

The advertisement features the BILT logo on the left, a QR code on the right, and a smartphone displaying a 3D assembly instruction. The text 'Scan for easy 3D instructions' is prominently displayed in the center, with a sub-headline 'Download the BILT app before you begin'. Below the text are two buttons: 'Download on the App Store' and 'GET IT ON Google Play'.

**BILT.**<sup>®</sup>

**Scan for easy  
3D instructions**

Download the BILT app  
before you begin

Download on the  
App Store

GET IT ON  
Google Play

Hardware Needed

17

# STEP 1 - DOOR ASSEMBLY

QTY	PART NUMBER	DESCRIPTION
20	H100087	SCREW PFH 8x1-1/4"
8	H100089	SCREW PFH 8x1-3/4"
4	H100128	SCREW PWH 8x5/8
13	H101191	SCREW PWH 6x1" BLK



**M19 DOOR BOARD - W4L17990**  
(x1) 5/8"x3 3/8"x26 5/8" (16x86x676)



**M20 DOOR BOARD - W4L17988**  
(x2) 5/8"x3 3/8"x40 1/2" (16x86x1030)

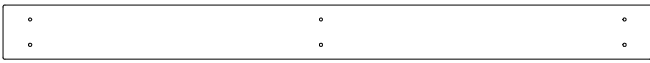

**M21 DOOR BOARD - W4L17986**  
(x2) 5/8"x3 3/8"x40 1/2" (16x86x1030)

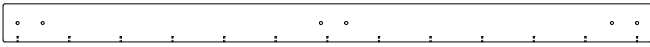

**J05 DOOR BOARD - W4L17987**  
(x1) 1"x2 3/8"x40 1/2" (24x60x1030)

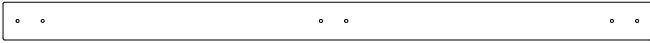

**J06 DOOR BOARD - W4L17985**  
(x1) 1"x2 3/8"x40 1/2" (24x60x1030)



**A4M02062 HINGE 1025mm**  
(x1)



**M18 DOOR BOARD - W4L17989**  
(x1) 5/8"x3 3/8"x5 1/4" (16x86x133)

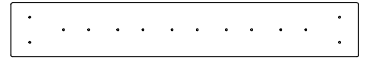

**H20 DOOR RAIL - W4L17984**  
(x2) 1"x3 3/8"x21 3/4" (24x86x552)

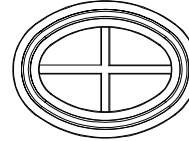

**A6P00052 OVAL WINDOW**  
(x1)

**NOTE:**  
FLUSH TOP, SIDE, & BOTTOM EDGES  
ON H20 BOARDS.  
ALIGN PILOT HOLES.

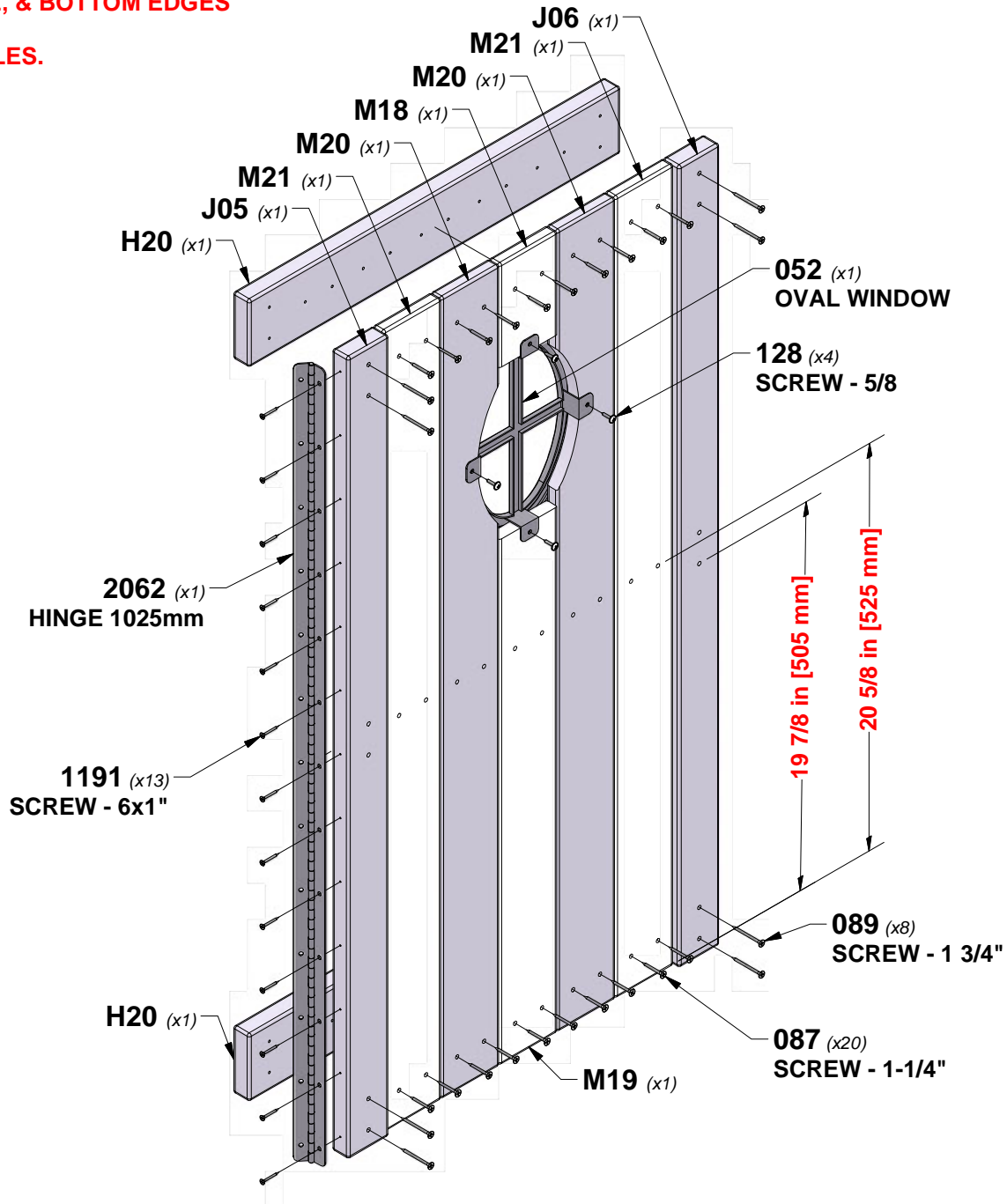

# STEP 1 - LADDER ASSEMBLY

QTY	PART NUMBER	DESCRIPTION
8	H100391	SCREW PFH 8x2 BLK



**E74 LEFT UPRIGHT - W4L17924**  
(x1) 1 3/8"x3 3/8"x57 1/4" (36x86x1453)



**H81 LADDER RUNG - W4L17927**  
(x4) 1"x3 3/8"x19 3/4" (24x86x502)

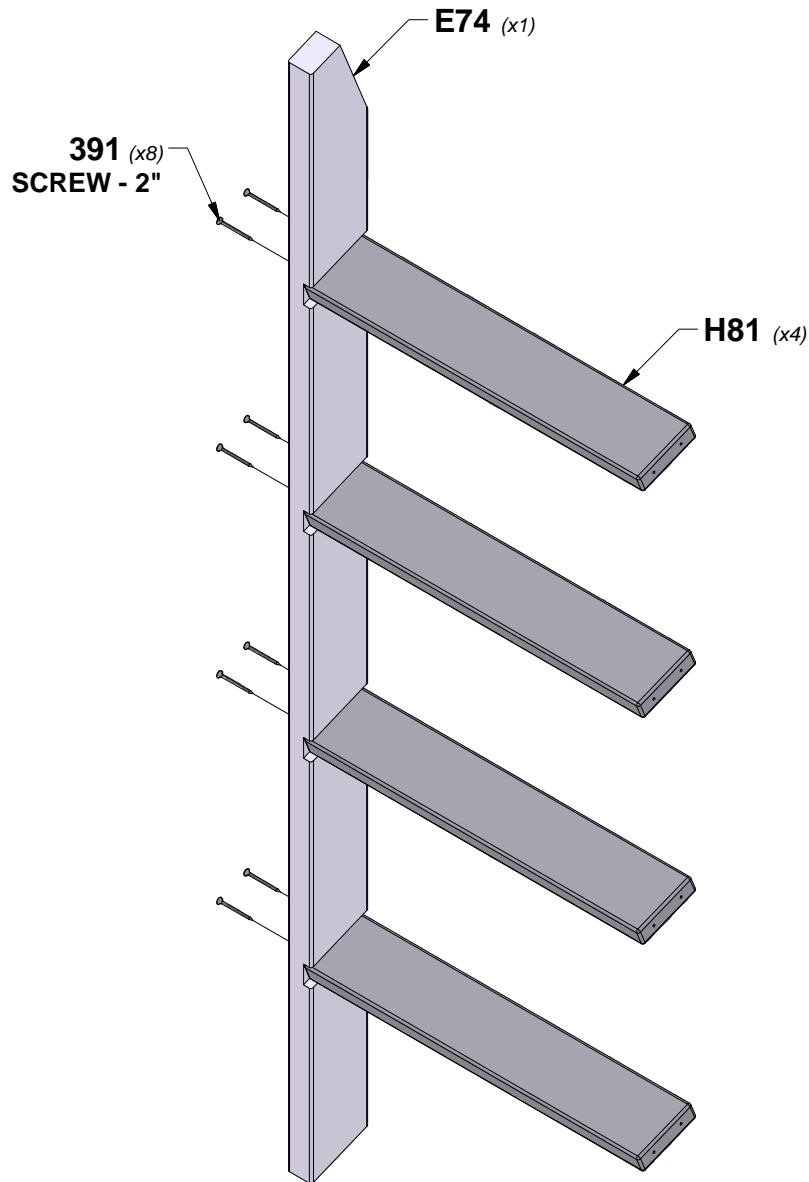



# STEP 2 - LADDER ASSEMBLY

QTY	PART NUMBER	DESCRIPTION
8	H100391	SCREW PFH 8x2 BLK

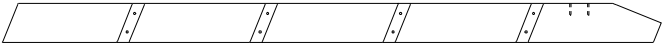

**E75 RIGHT UPRIGHT - W4L17925**  
(x1) 1 3/8"x3 3/8"x57 1/4" (36x86x1453)

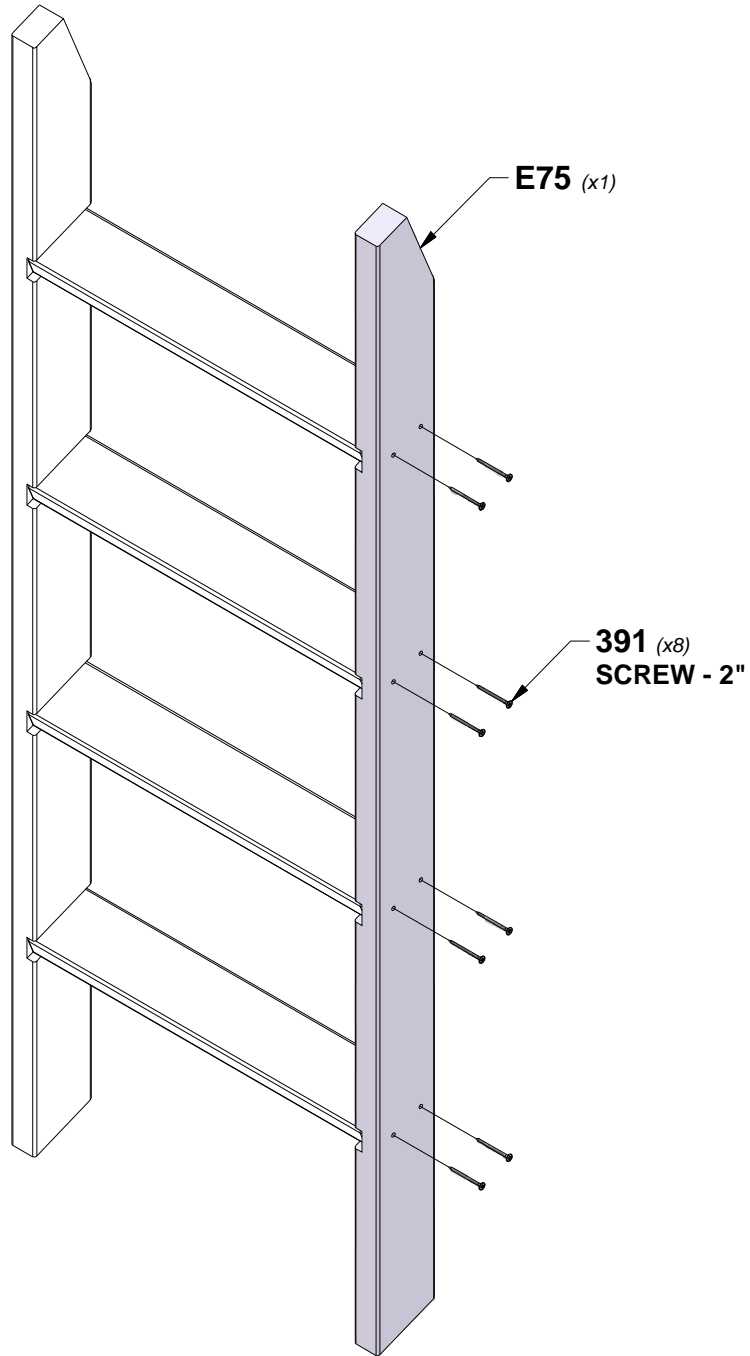

# STEP 3 - LADDER ASSEMBLY

QTY	PART NUMBER	DESCRIPTION
4	H100200	SCREW PFH 8x1-1/2 BLK
4	H100391	SCREW PFH 8x2 BLK



**H102 ATTACHMENT BOARD - W4L17928**  
 (x1) 1"x3 3/8"x21 5/8" (24x86x550)



**M103 REAR SUPPORT - W4L17926**  
 (x1) 5/8"x3 3/8"x21 5/8" (16x86x550)

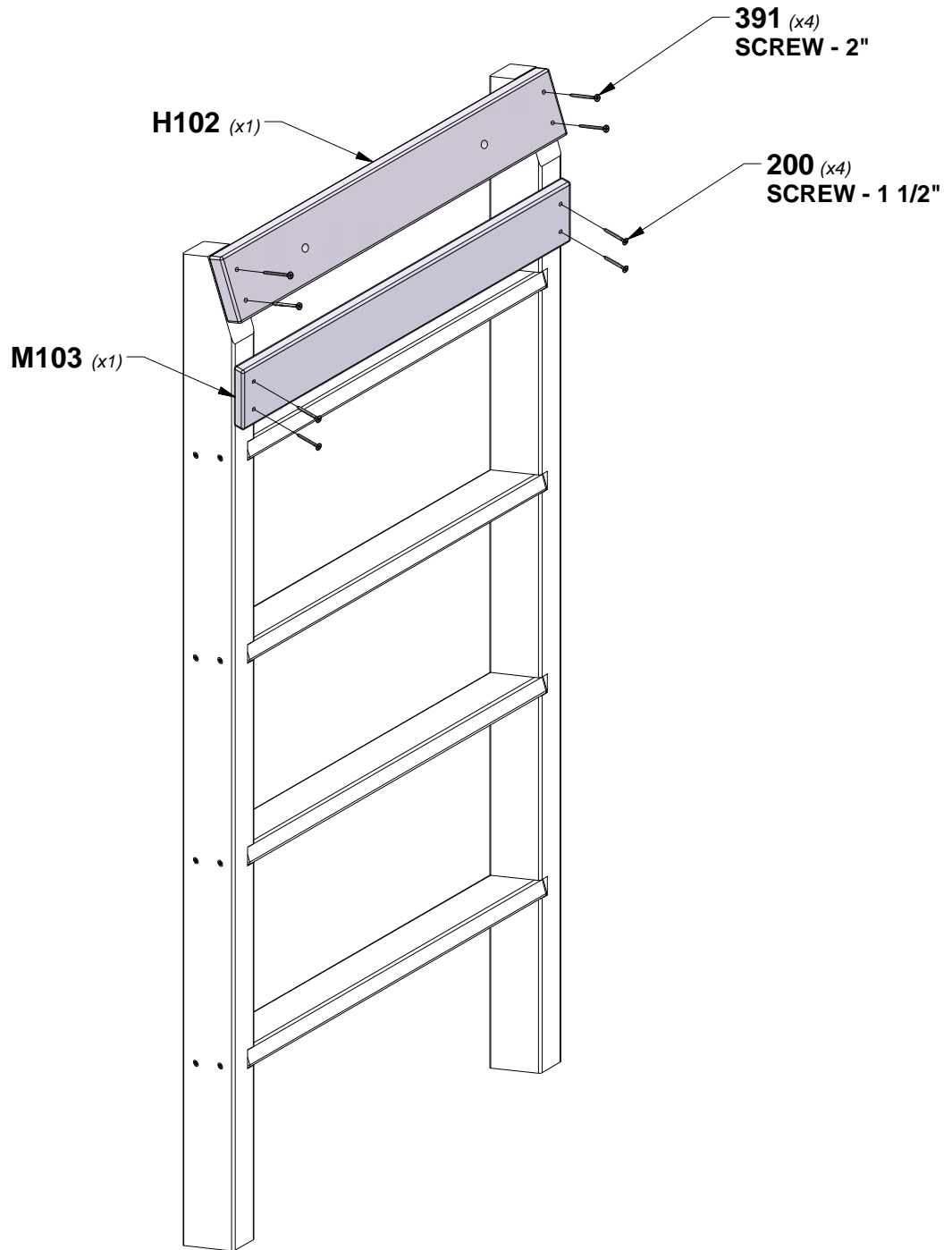

# STEP 1 - ROCK WALL

QTY	PART NUMBER	DESCRIPTION
20	H100398	T-NUT 1/4 BLK
20	H100473	WASHER LOCK INT 8x15 BLK
20	H101111	BOLT WH 1/4x3/4 BLK



**M75 ROCK WALL BOARD - W4L17933**  
(4) 5/8"x3 3/8"x22 7/8" (16x86x580)



**M76 ROCK WALL BOARD - W4L17934**  
(3) 5/8"x3 3/8"x22 7/8" (16x86x580)



**A6P00592**  
(5) **GREY HC ROCK #1**



**A6P00593**  
(5) **GREY HC ROCK #2**

**TIP:**  
**INSTALL T-NUTS IN WOOD FIRST**

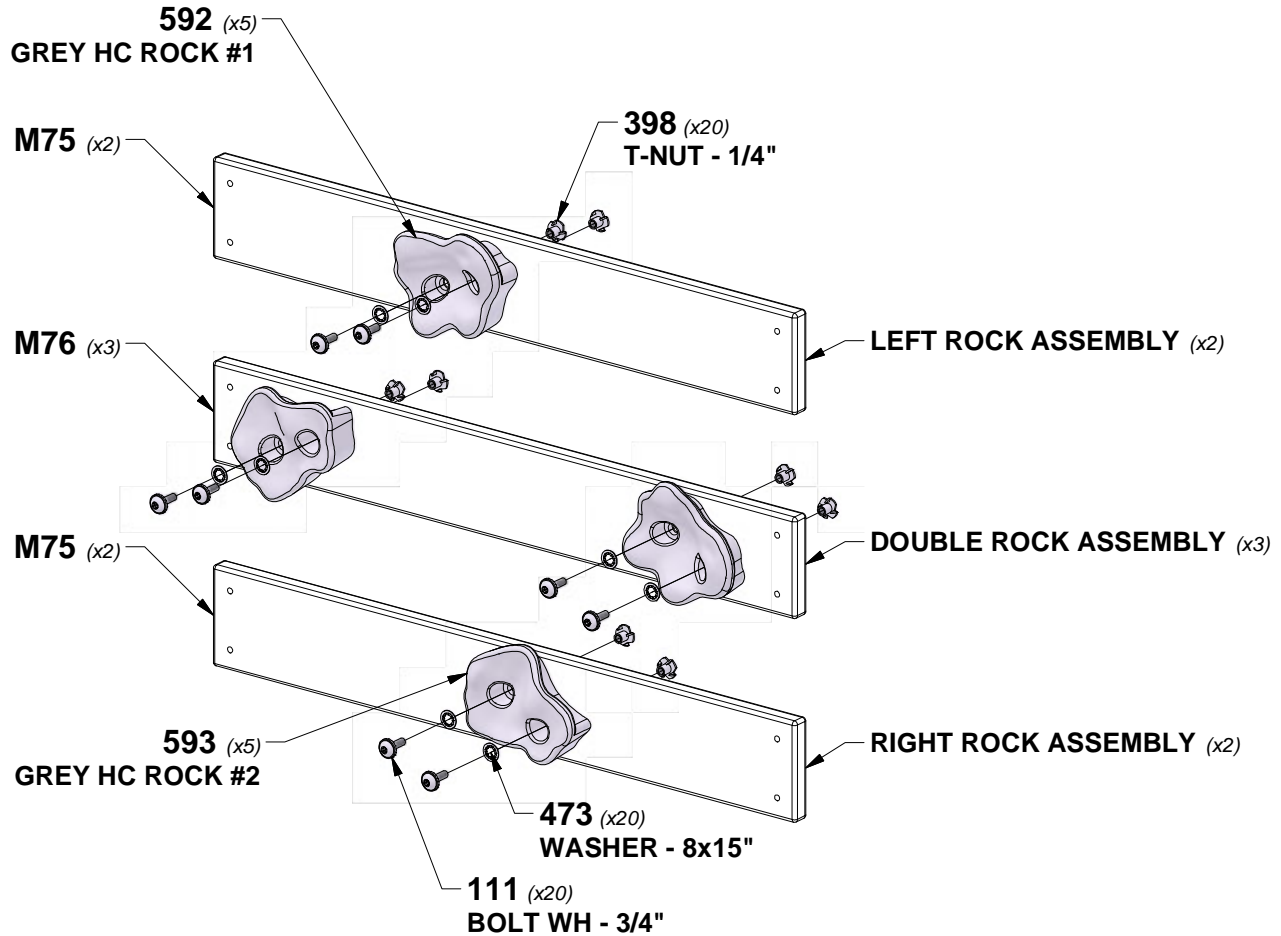
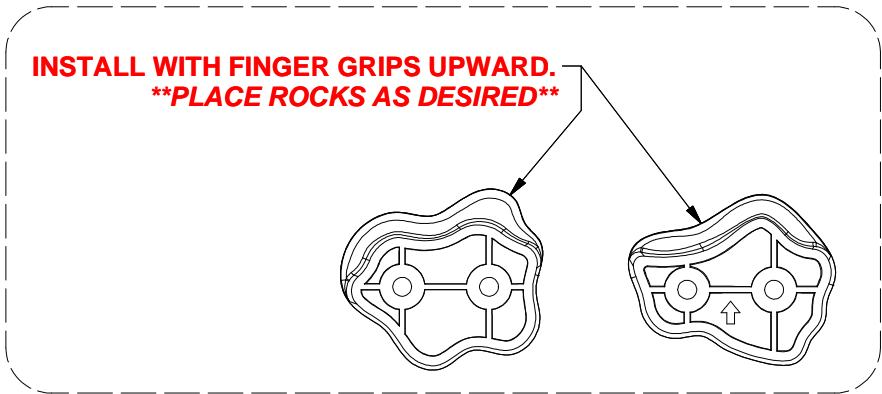

# STEP 2 - ROCK WALL

QTY	PART NUMBER	DESCRIPTION
66	H100089	SCREW PFH 8x1-3/4"



(2) LEFT ROCK ASSEMBLY

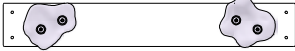

(3) DOUBLE ROCK ASSEMBLY



(2) RIGHT ROCK ASSEMBLY

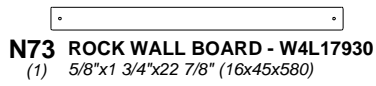

**N73 ROCK WALL BOARD - W4L17930**  
(1) 5/8"x1 3/4"x22 7/8" (16x45x580)



**M74 ROCK WALL BOARD - W4L17932**  
(9) 5/8"x3 3/8"x22 7/8" (16x86x580)



**E72 ROCKWALL RAIL - W4L17929**  
(2) 1 3/8"x3 3/8"x57 3/8" (36x86x1457)

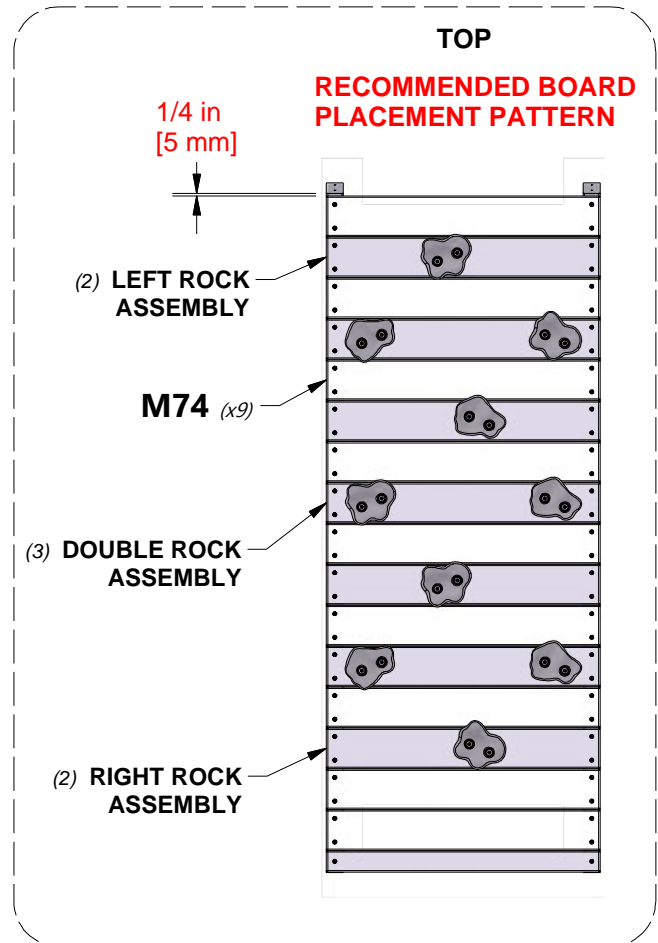
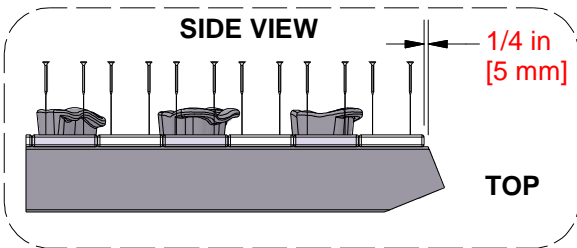
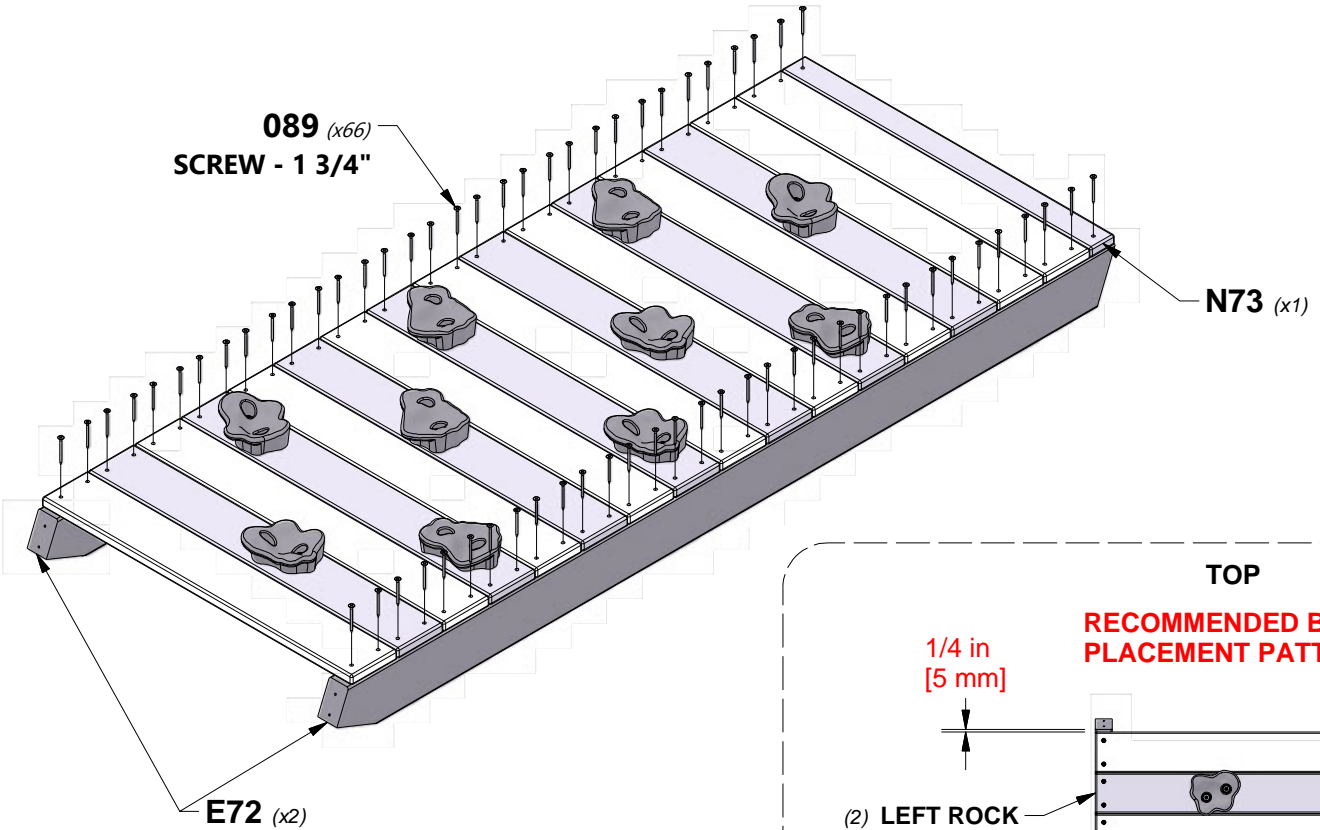

# STEP 3 - ROCK WALL

QTY	PART NUMBER	DESCRIPTION
4	H100087	SCREW PFH 8x1-1/4"



**Y78 ROCK WALL END BOARD - W4L17935**  
(1) 5/8"x3 7/8"x22 7/8" (16x98x580)

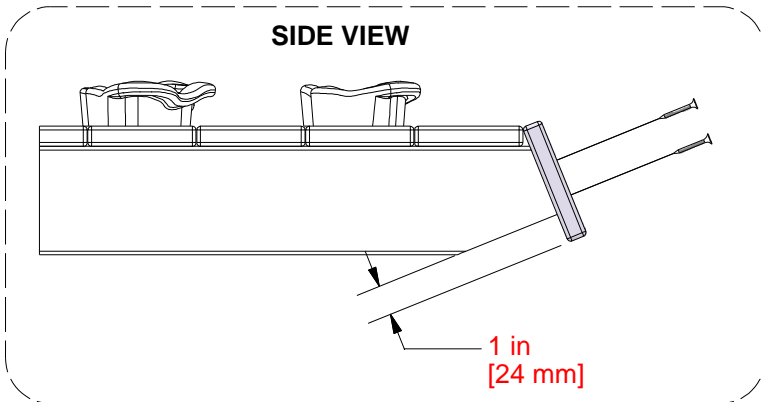
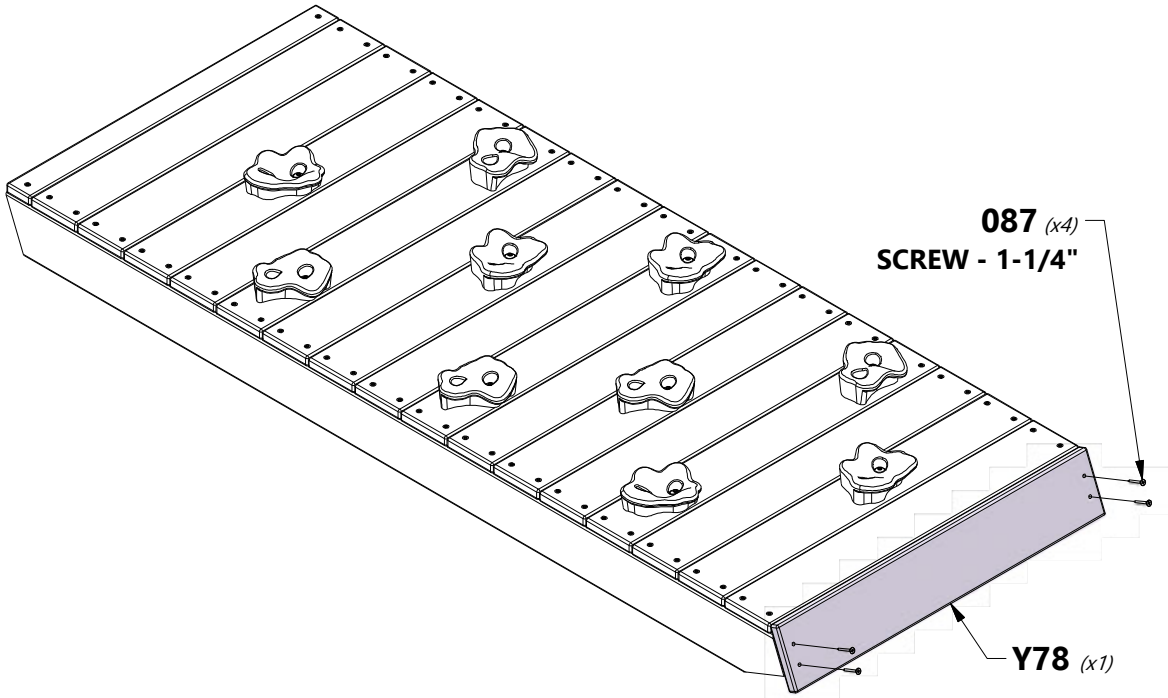

# STEP 4 - ROCK WALL

QTY	PART NUMBER	DESCRIPTION
2	H100379	T-NUT 5/16 BLK
4	H100391	SCREW PFH 8x2 BLK



**H77 ATTACHMENT BOARD - W4L17931**  
 (1) 1"x3 3/8"x22 7/8" (24x86x580)

**TIP:**  
**INSTALL T-NUTS IN WOOD FIRST**

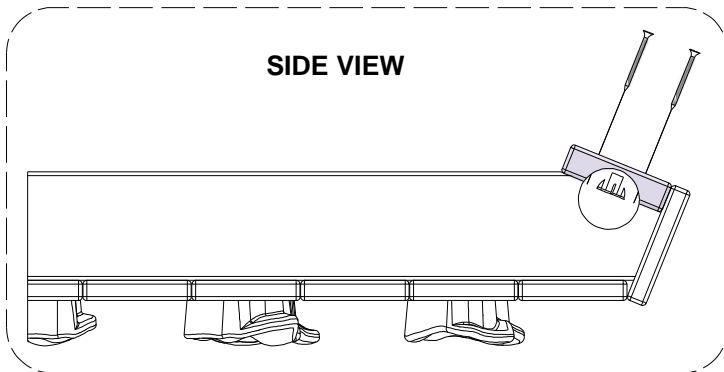
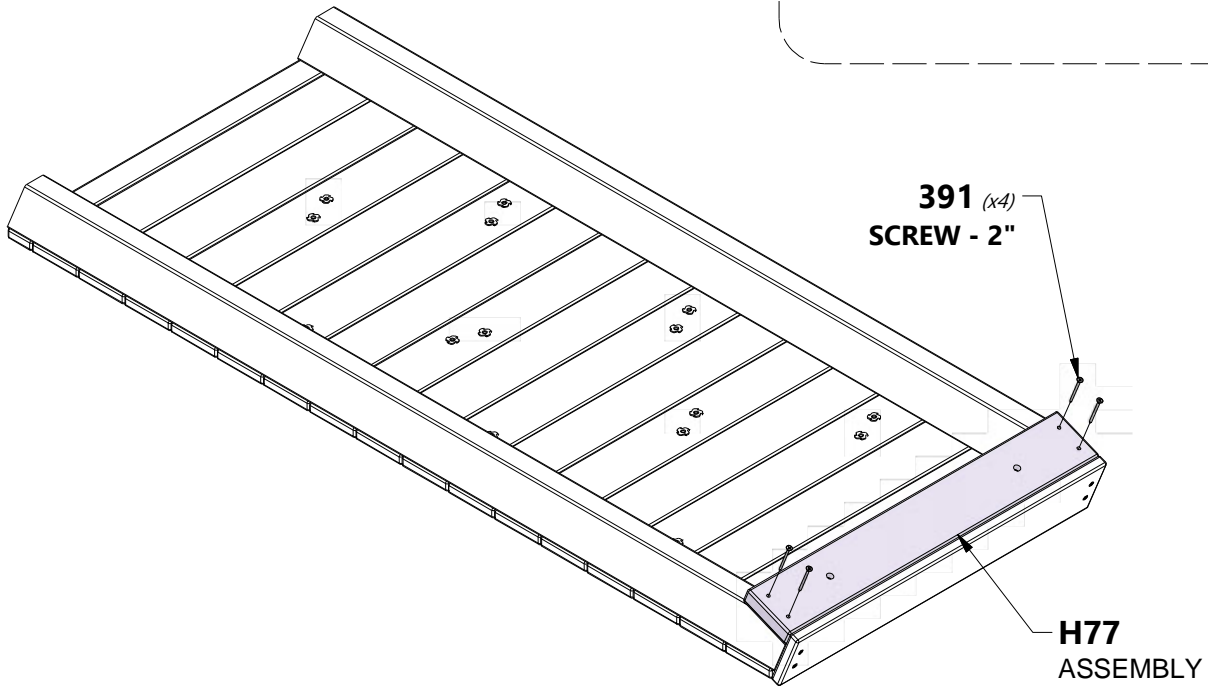
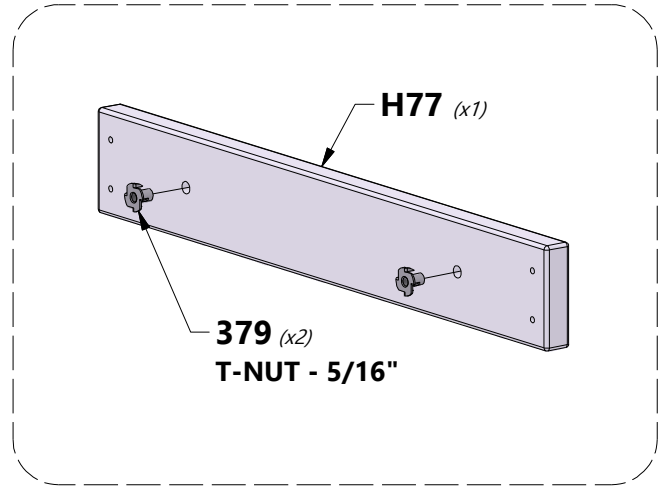

**NOTE:**  
**T-NUTS TO THE INSIDE**  
**WHEN INSTALLING BOARD**

# STEP 1 - SWING BEAM



**A50 SWING BEAM - W4L17936**  
(x1) 3 3/8"x5 1/4"x89 1/2" (86x134x2274)



**A4M00619 L BRACKET**  
(x2) 66x66x127 - BLK

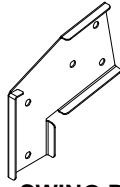

**A4M00617 SWING BEAM EXTENSION BRACKET-LEFT**  
(x1)

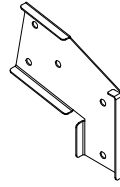

**A4M00618 SWING BEAM EXTENSION BRACKET-RIGHT**  
(x1)

QTY	PART NUMBER	DESCRIPTION
3	H100192	NUT BARREL WH 5/16x7/8 BLK
3	H100416	BOLT WH 5/16x3 BLK
2	H100476	BOLT HEX 5/16x4 1/4 BLK
4	H100478	WASHER FLAT 8x27 BLK
2	H100479	NUT LOCK 5/16 BLK

**TIP:**  
LEAVE 416 BOLTS & 192 NUT BARRELS HAND TIGHT.

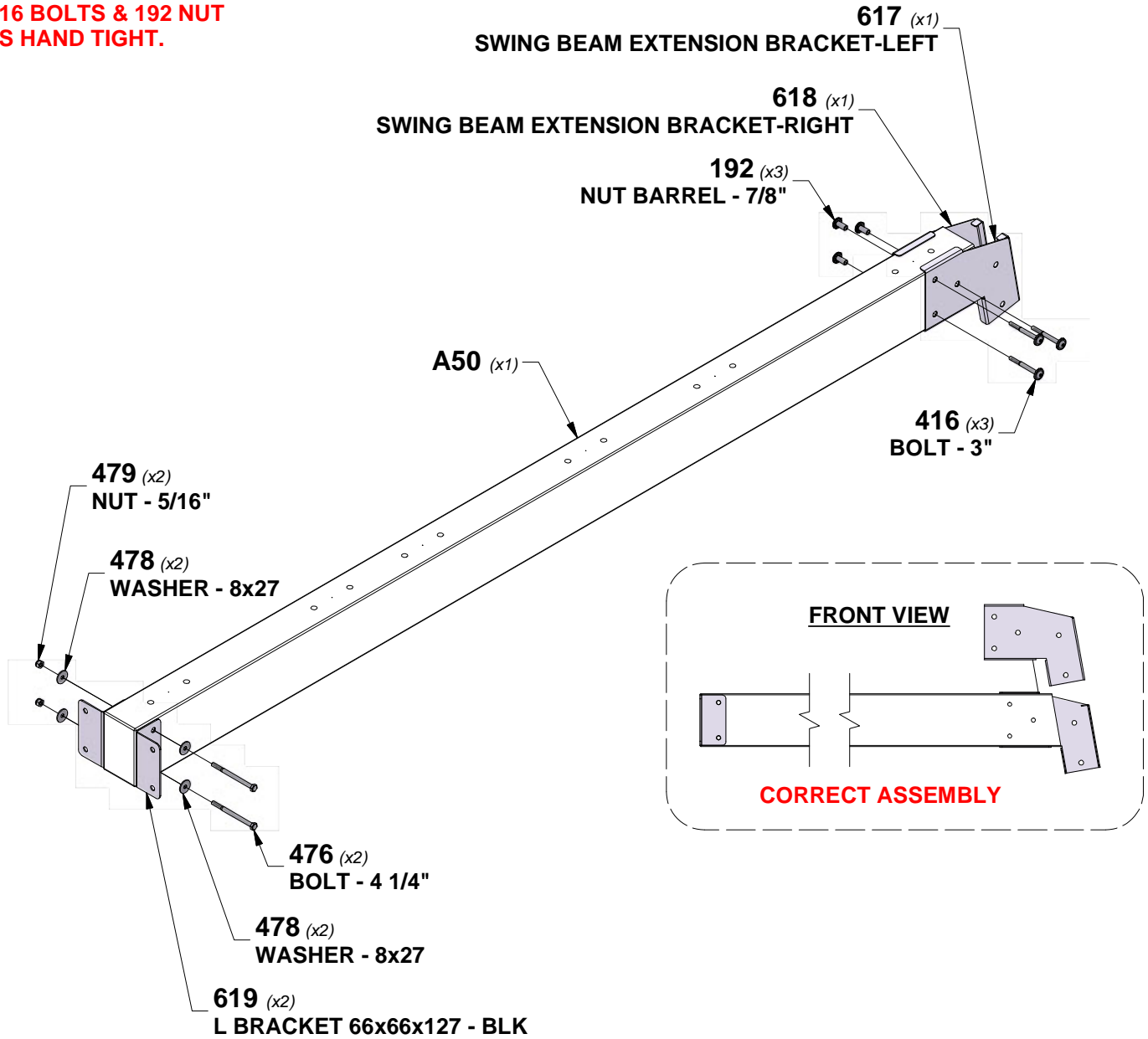

# STEP 2 - SWING BEAM

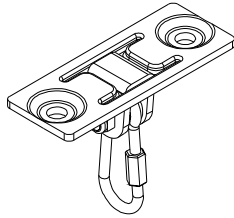

**A4M02171**  
(x6) **SWING HANGER**

QTY	PART NUMBER	DESCRIPTION
12	H101166	WASHER LOCK INT 10x18 BLK
12	H101167	WASHER FLAT 11x25 BLK
12	H101168	T-NUT 3/8 BLK
12	H101169	BOLT HEX 3/8x5-1/2 BLK

**TIP:**  
**INSTALL T-NUTS IN WOOD FIRST**

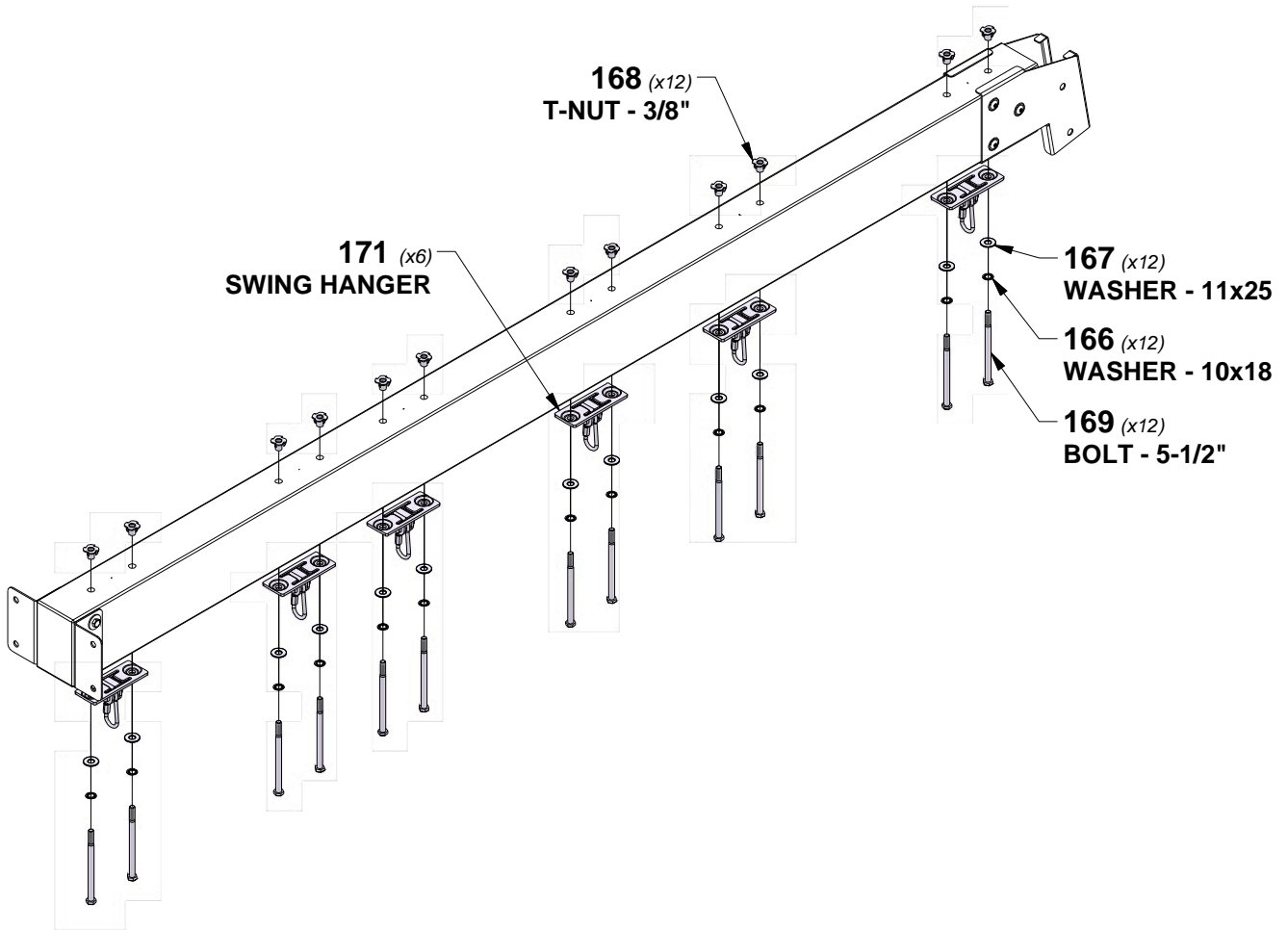



# STEP 3 - SWING BEAM

QTY	PART NUMBER	DESCRIPTION
4	H100202	SCREW PWH 8x5/8 BLK



**A100164** BYD ID TAG  
(x1) (LARGE) AGES  
3-10

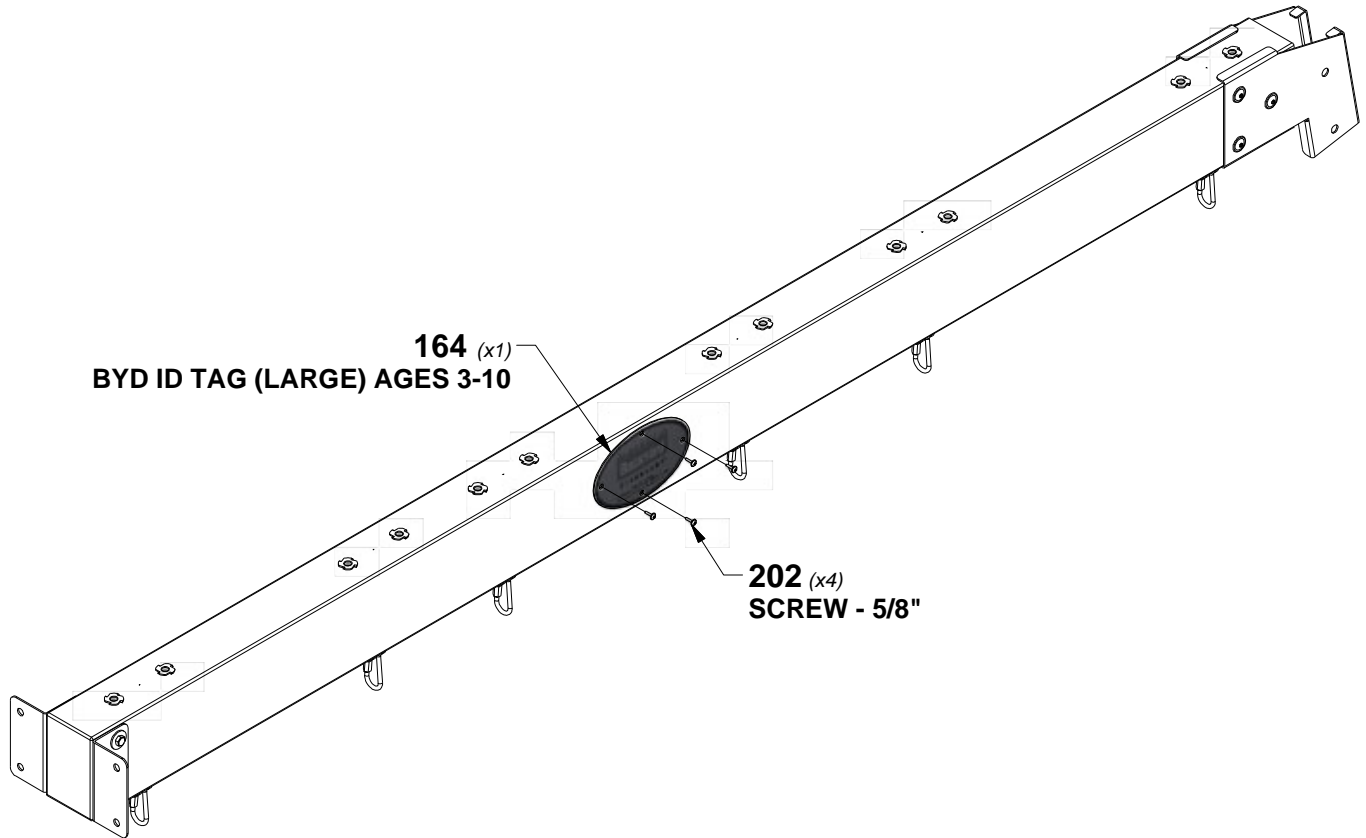
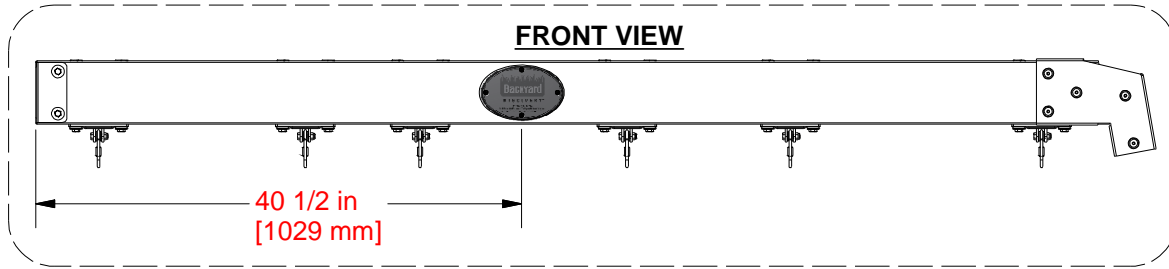

# STEP 4 - SWING BEAM

QTY	PART NUMBER	DESCRIPTION
6	H100379	T-NUT 5/16 BLK
4	H100407	BOLT WH 5/16x1 1/2 BLK
2	H100503	BOLT WH 5/16x3-1/2 BLK

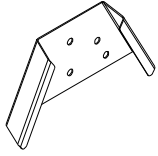

**A4M01782** A-FRAME BRACKET  
(x1)

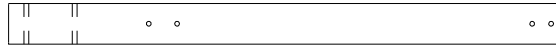

**SP71** SWING BEAM SUPPORT - W4L17937  
(x1) 3 3/8"x3 3/8"x46 1/8" (86x86x1172)



**E80** ANGLE BRACE - W4L17938  
(x2) 1 3/8"x3 3/8"x87 1/8" (36x86x2212)

**TIP:**  
INSTALL T-NUTS IN WOOD FIRST

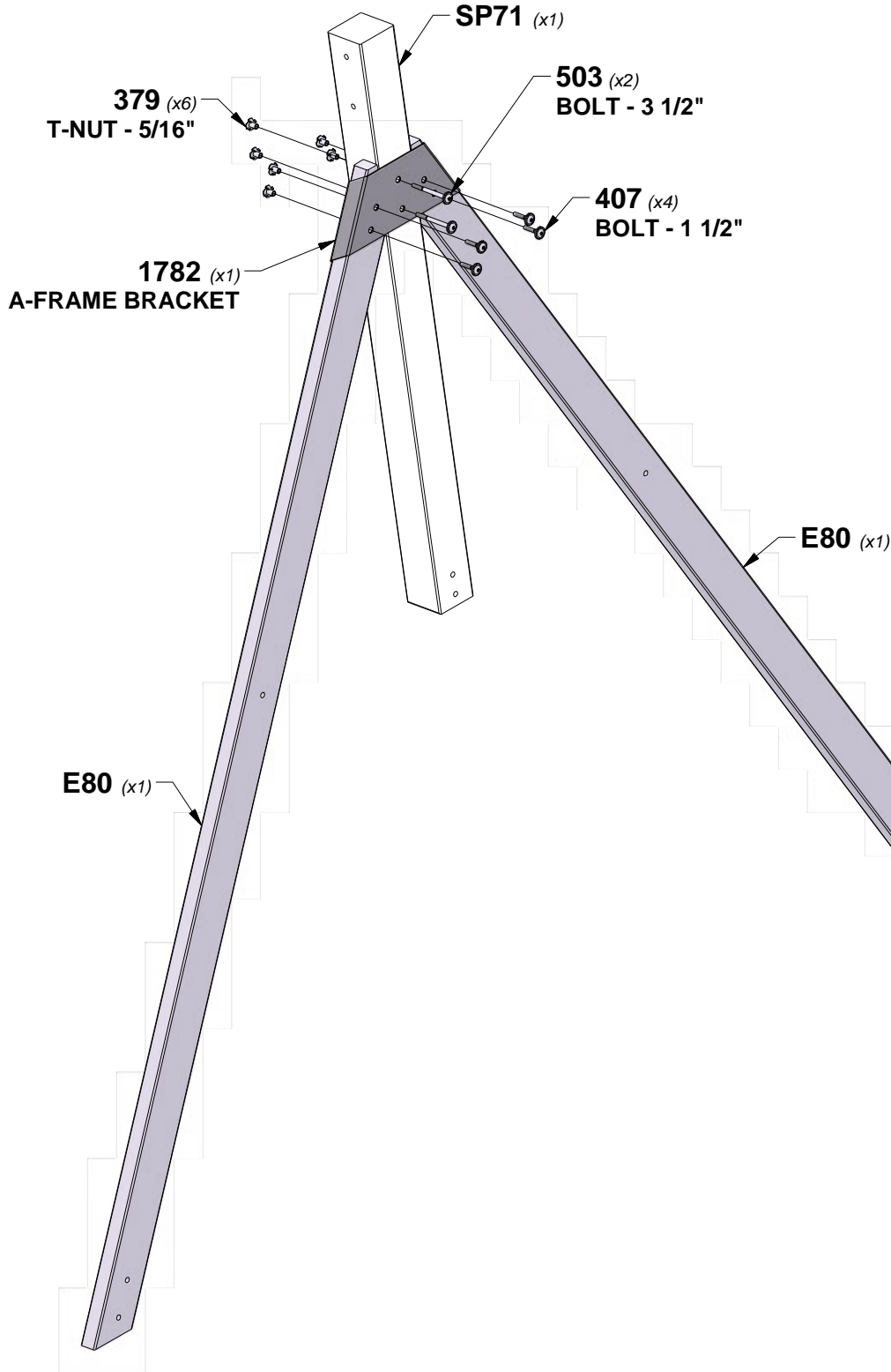

# STEP 5 - SWING BEAM

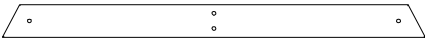

**E79 END SUPPORT - W4L17939**  
(x1) 1 1/2"x3 1/2"x44" (36x86x1120)



**G50 GROUND BOARD - W4L17940**  
(x1) 1"x5 1/4"x86 11/16" (24x134x2202)

QTY	PART NUMBER	DESCRIPTION
2	H100195	BOLT WH 5/16x2-3/4 BLK
8	H100198	WASHER LOCK EXT 8x19 BLK
4	H100205	BOLT WH 5/16x2-1/4 BLK
8	H100379	T-NUT 5/16 BLK
2	H100480	BOLT WH 5/16x4 3/4 BLK

**TIP:**  
**INSTALL T-NUTS IN WOOD FIRST**

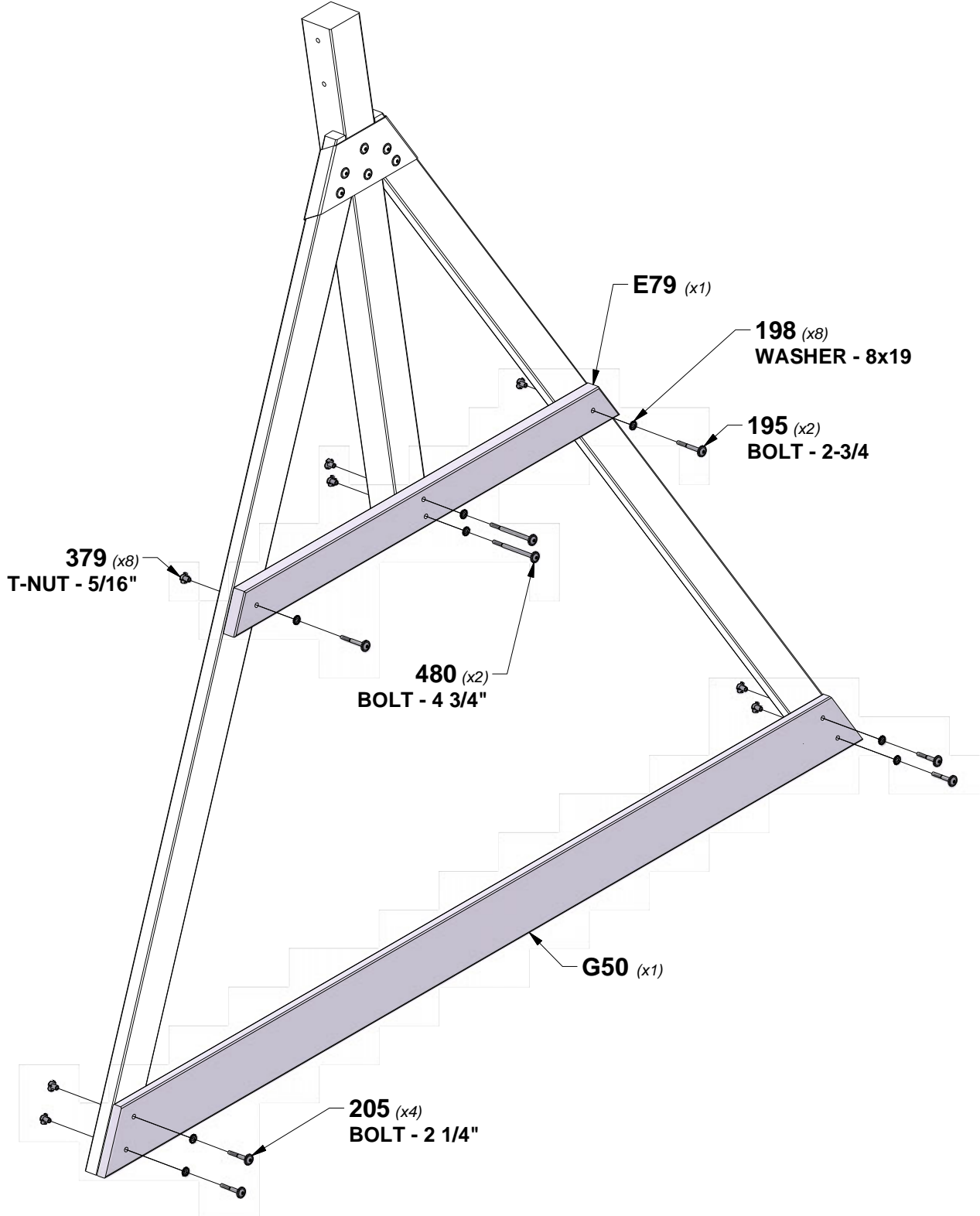

# STEP 6 - SWING BEAM

QTY	PART NUMBER	DESCRIPTION
2	H100192	NUT BARREL WH 5/16x7/8 BLK
2	H100416	BOLT WH 5/16x3 BLK

**TIP:**  
**TIGHTEN ALL (5) 416 BOLTS & 192 NUT BARRELS NOW.**

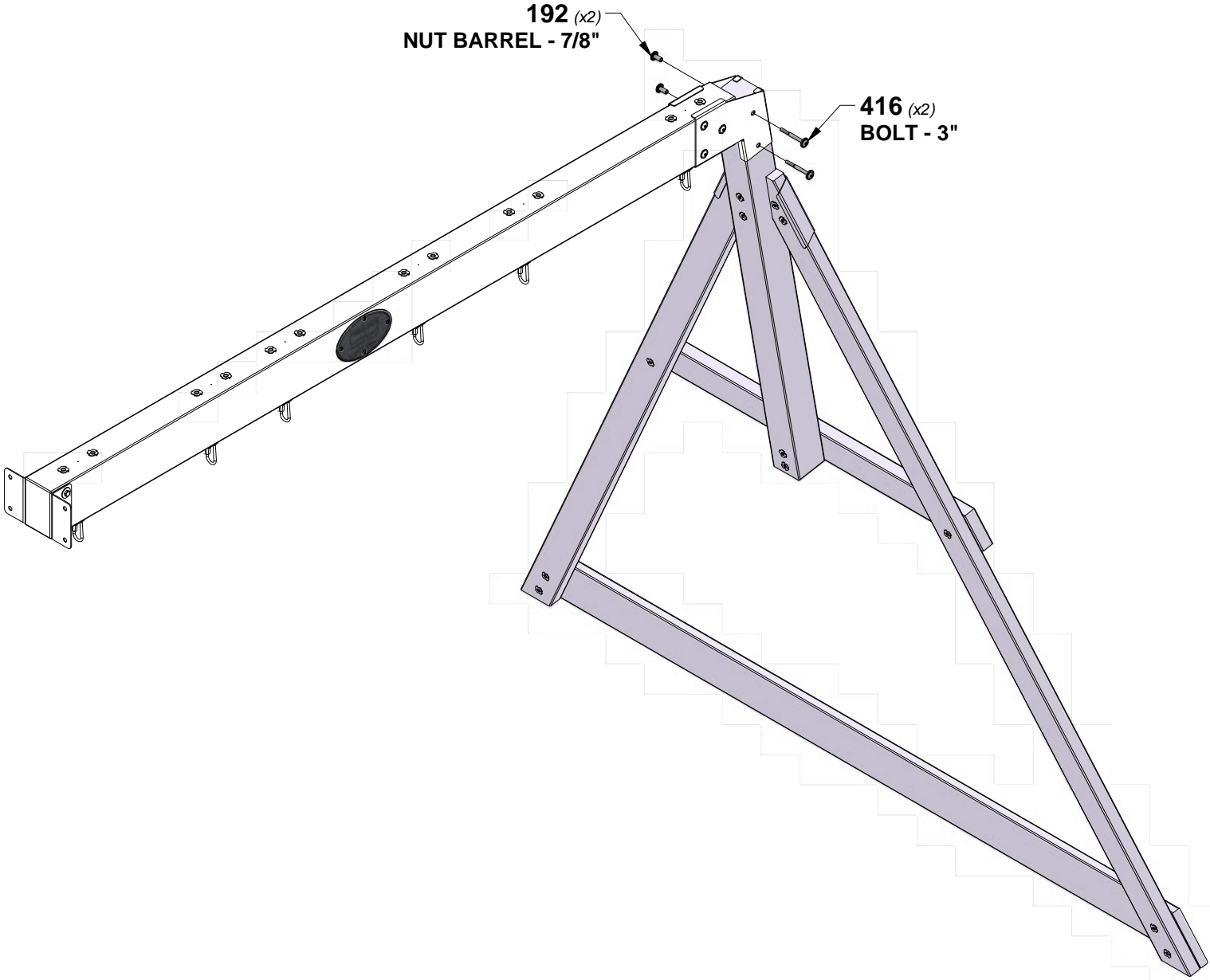

# STEP 1 - FORT ASSEMBLY

QTY	PART NUMBER	DESCRIPTION
11	H100198	WASHER LOCK EXT 8x19 BLK
11	H100379	T-NUT 5/16 BLK
9	H100415	BOLT WH 5/16x3 3/4 BLK
2	H100480	BOLT WH 5/16x4 3/4 BLK

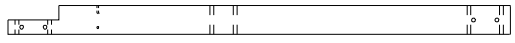

**B02 POST - W4L17693**  
(x1) 3"x3"x52 3/8" (76x76x1330)

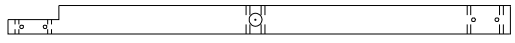

**B03 POST - W4L17694**  
(x1) 3"x3"x52 3/8" (76x76x1330)

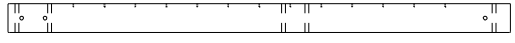

**B07 POST - W4L17700**  
(x1) 3"x3"x52 3/8" (76x76x1330)



**G07 FLOOR RAIL - W4L17706**  
(x1) 1"x5 1/4"x80" (24x134x2032)

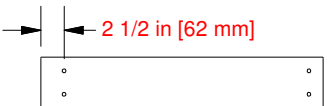

**G03 GROUND BOARD - W4L17701**  
(x1) 1"x5 1/4"x29 1/2" (24x134x748)



**G09 GROUND BOARD - W4L17710**  
(x1) 1"x5 1/4"x52 5/8" (24x134x1336)

**TIP:**  
**INSTALL T-NUTS IN WOOD FIRST**

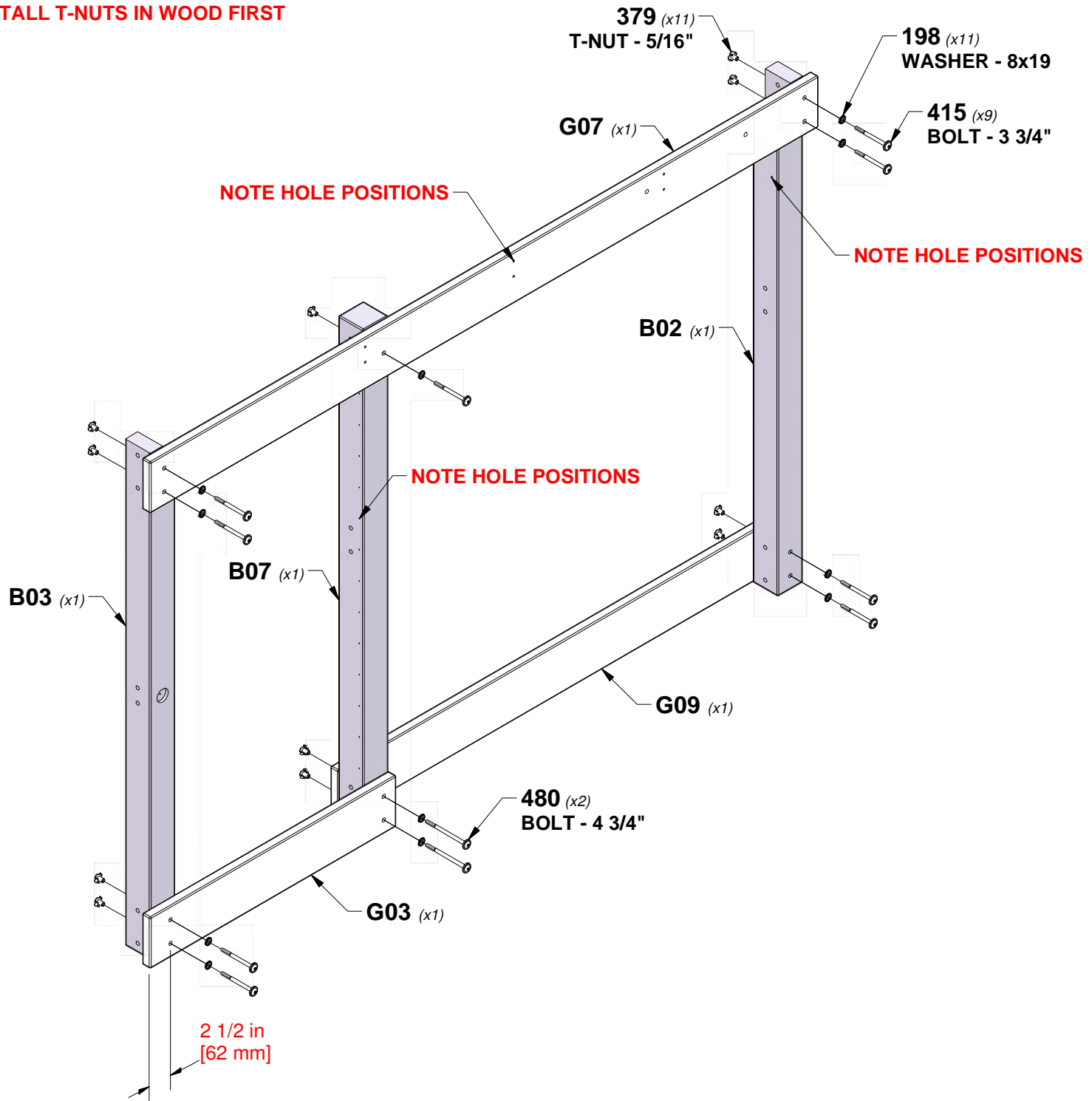

# STEP 2 - FORT ASSEMBLY

QTY	PART NUMBER	DESCRIPTION
1	H100387	SCREW PFH 8x1-1/4" BLK

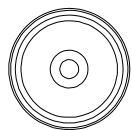

**A4M02063 MAGNETIC  
(x1) DOOR CATCH**

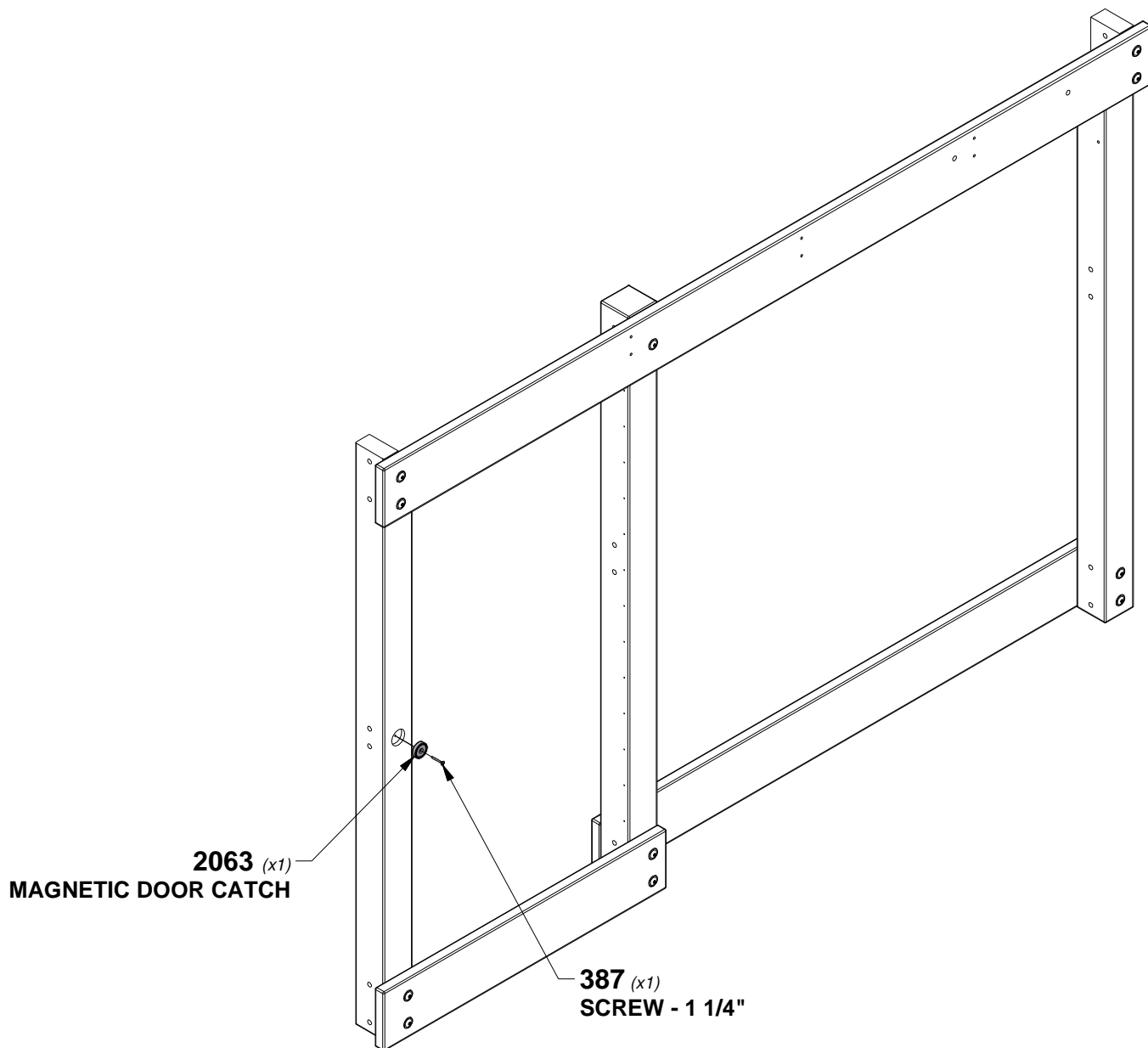

# STEP 3 - FORT ASSEMBLY

QTY	PART NUMBER	DESCRIPTION
8	H100198	WASHER LOCK EXT 8x19 BLK
8	H100379	T-NUT 5/16 BLK
8	H100415	BOLT WH 5/16x3 3/4 BLK



**B01 POST - W4L17692**  
(x1) 3"x3"x52 3/8" (76x76x1330)

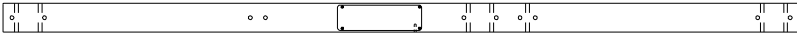

**B04 W2A03754 - POST**  
(x1) 3"x3"x83" (76x76x2108)



**G01 GROUND BOARD - W4L17698**  
(x1) 1"x5 1/4"x80" (24x134x2032)



**G04 FLOOR RAIL - W4L17703**  
(x1) 1"x5 1/4"x80" (24x134x2032)

**TIP:**  
**INSTALL T-NUTS IN WOOD FIRST**

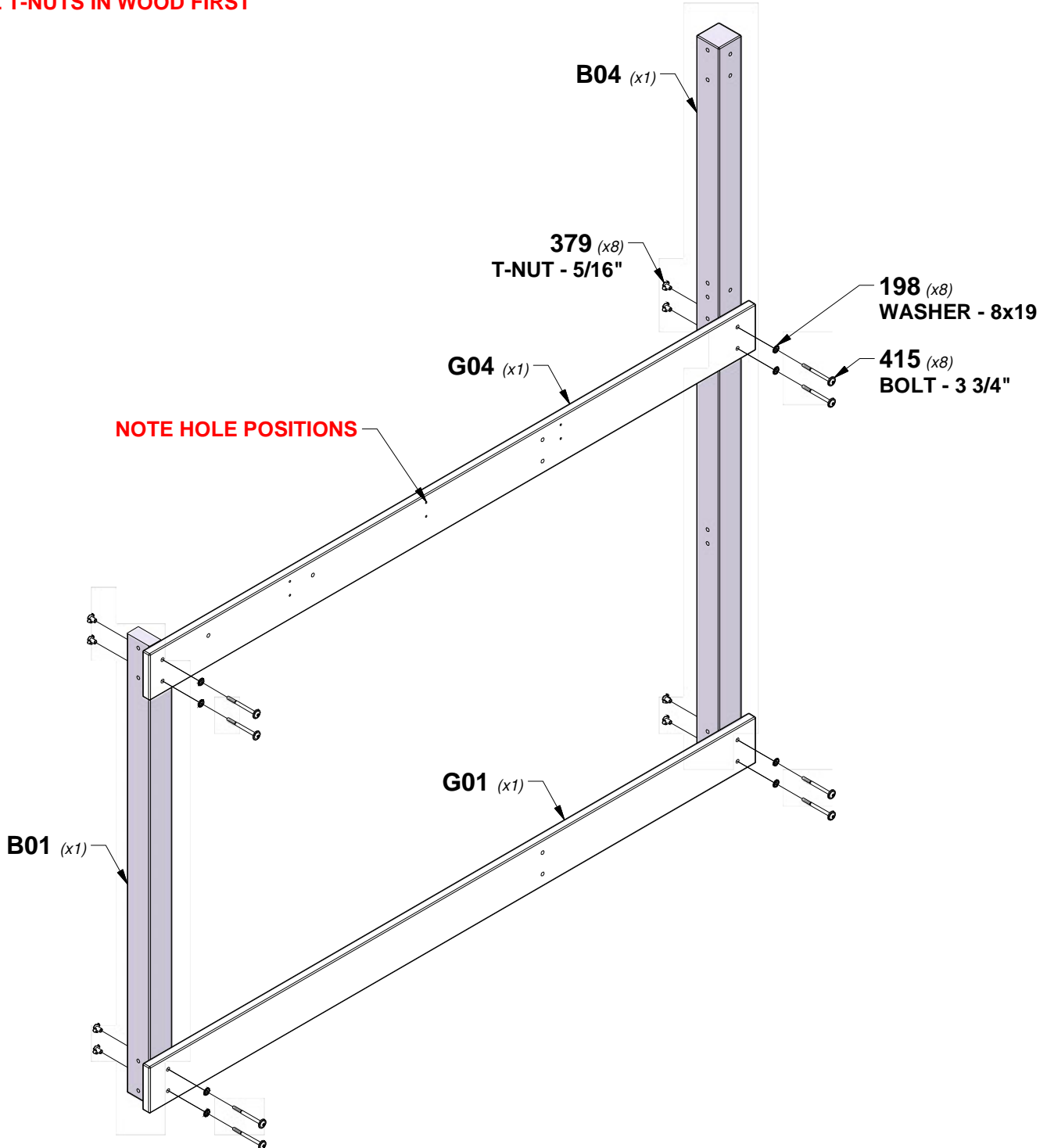

# STEP 4 - FORT ASSEMBLY

QTY	PART NUMBER	DESCRIPTION
4	H100198	WASHER LOCK EXT 8x19 BLK
4	H100205	BOLT WH 5/16x2 1/4 BLK
4	H100379	T-NUT 5/16 BLK



**E08 POST - W4L17735**  
 (x1) 1 3/8"x3 3/8"x52 3/8" (36x86x1330)

**TIP:**  
**INSTALL T-NUTS IN WOOD FIRST**

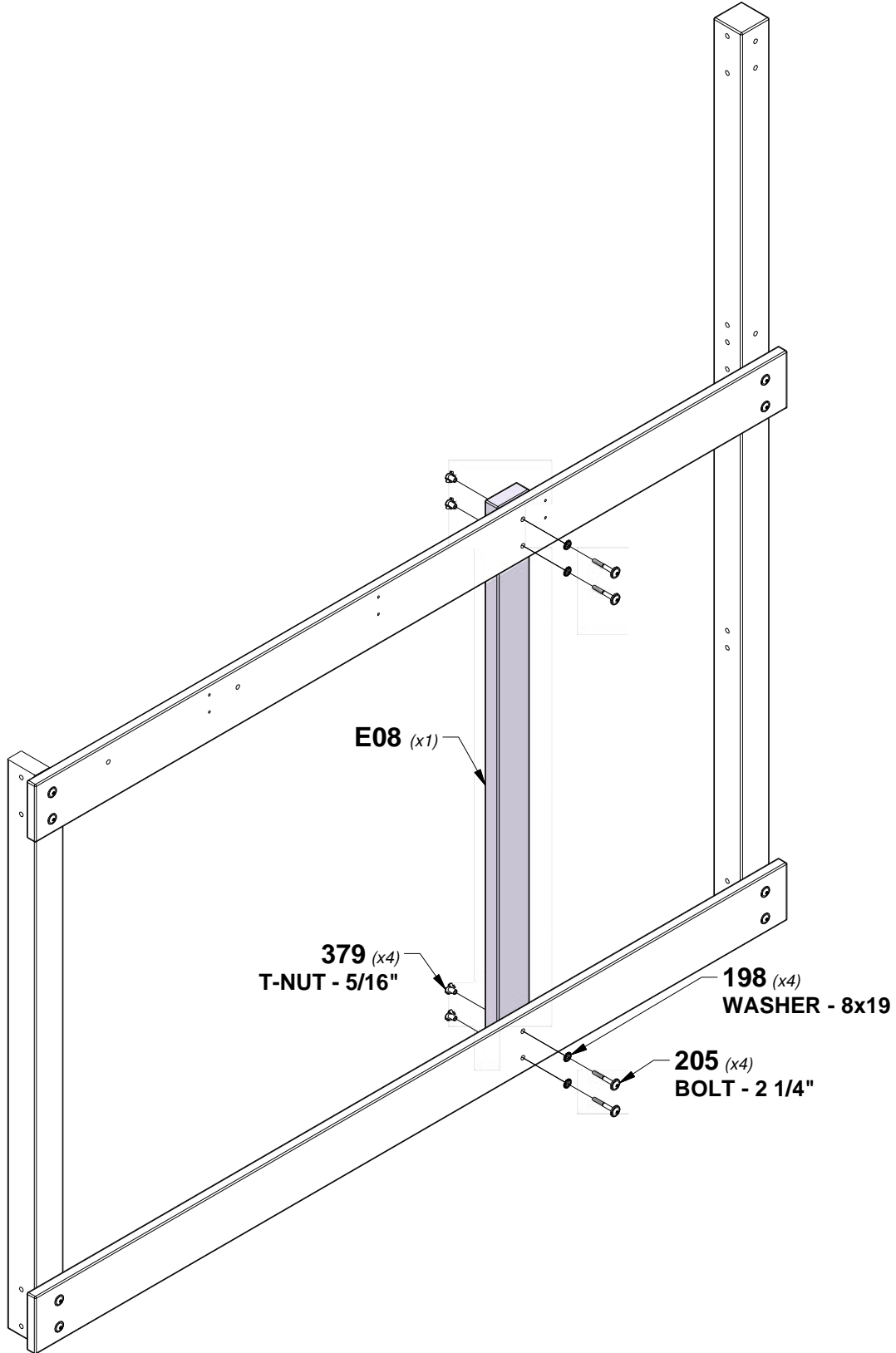



# STEP 5 - FORT ASSEMBLY

QTY	PART NUMBER	DESCRIPTION
4	H100198	WASHER LOCK EXT 8x19 BLK
4	H100379	T-NUT 5/16 BLK
4	H100415	BOLT WH 5/16x3 3/4 BLK

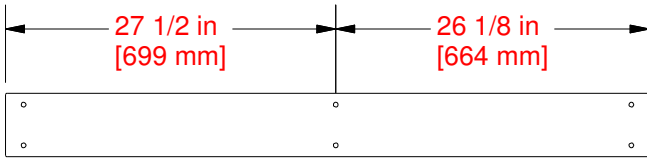

**G08 GROUND BOARD - W4L17708**  
 (x1) 1"x5 1/4"x53 5/8" (24x134x1363)

**TIP:**  
**INSTALL T-NUTS IN WOOD FIRST**

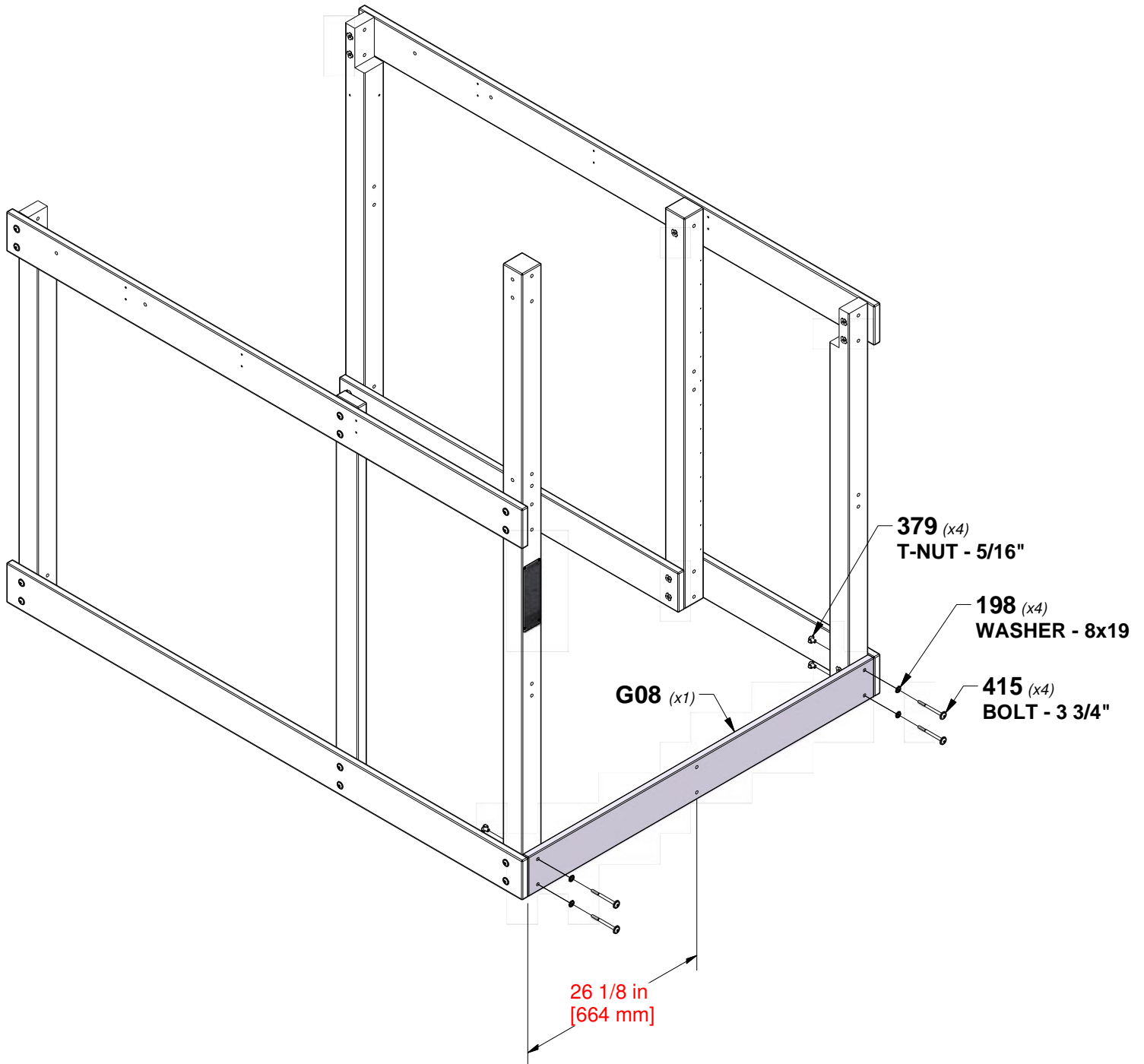

# STEP 6 - FORT ASSEMBLY

QTY	PART NUMBER	DESCRIPTION
4	H100198	WASHER LOCK EXT 8x19 BLK
4	H100379	T-NUT 5/16 BLK
4	H100415	BOLT WH 5/16x3 3/4 BLK

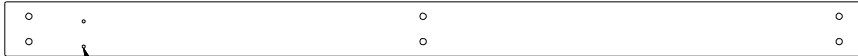

**H01 LOWER RAIL - W4L17719**  
 (x1) 1"x3 3/8"x53 5/8" (24x86x1363)

**NOTE HOLES DOWNWARD  
 WHEN INSTALLED**

**TIP:  
 INSTALL T-NUTS IN WOOD FIRST**

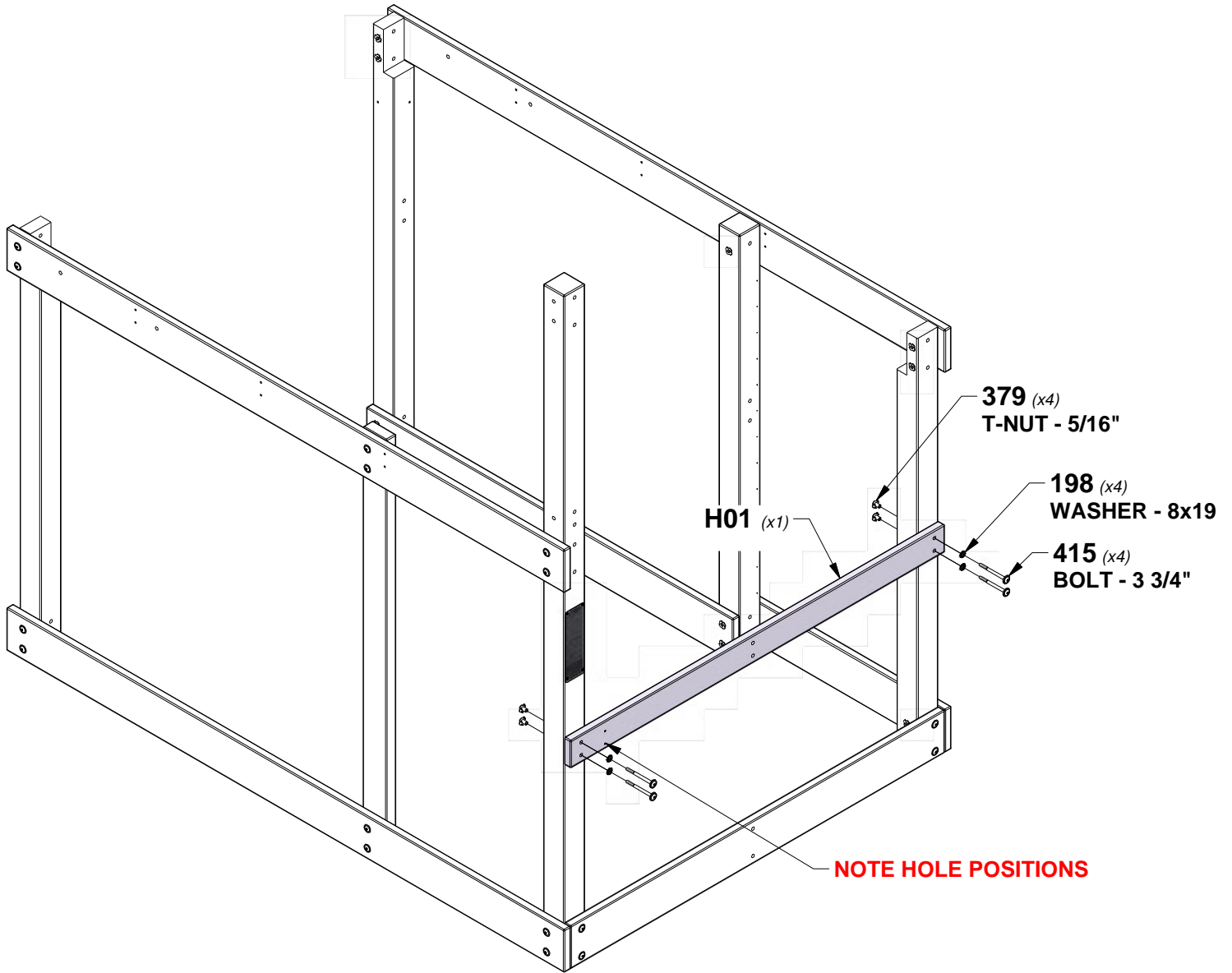

# STEP 7 - FORT ASSEMBLY



**G06 FLOOR RAIL - W4L17705**  
(x1) 1"x5 1/4"x53 5/8" (24x134x1363)



**B08 POST - W4L17720**  
(x1) 3"x3"x89 1/2" (76x76x2273)

QTY	PART NUMBER	DESCRIPTION
3	H100198	WASHER LOCK EXT 8x19 BLK
3	H100379	T-NUT 5/16 BLK
3	H100415	BOLT WH 5/16x3 3/4 BLK

**TIP:**  
**INSTALL T-NUTS IN WOOD FIRST**

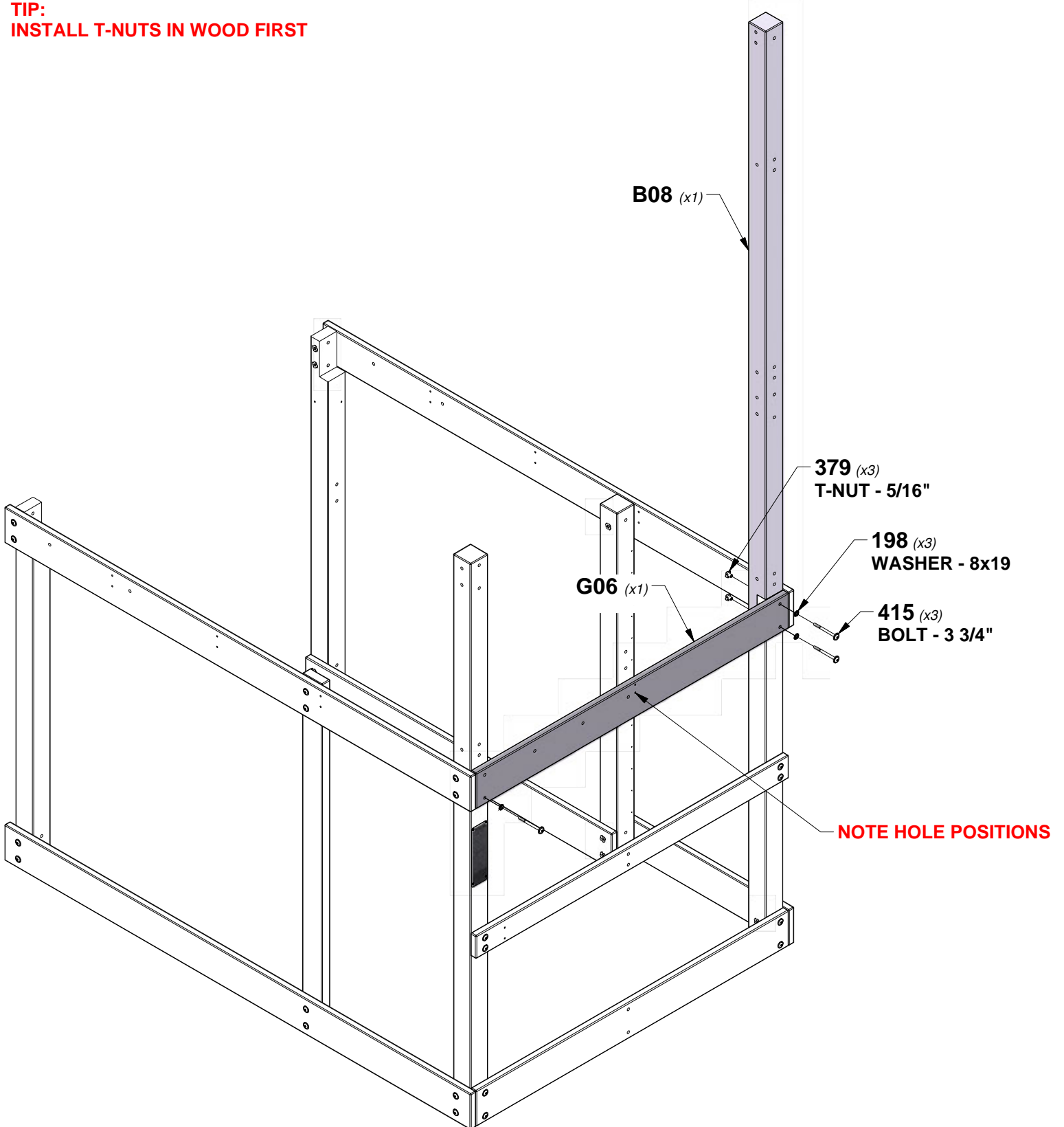

# STEP 8 - FORT ASSEMBLY

QTY	PART NUMBER	DESCRIPTION
1	H100198	WASHER LOCK EXT 8x19 BLK
1	H100379	T-NUT 5/16 BLK
1	H100480	BOLT WH 5/16x4 3/4 BLK

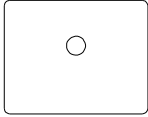

**J01 FLOOR SUPPORT - W4L17729**  
(x1) 15/16"x3"x2 3/8" (24x76x60)

**TIP:**  
**INSTALL T-NUTS IN WOOD FIRST**

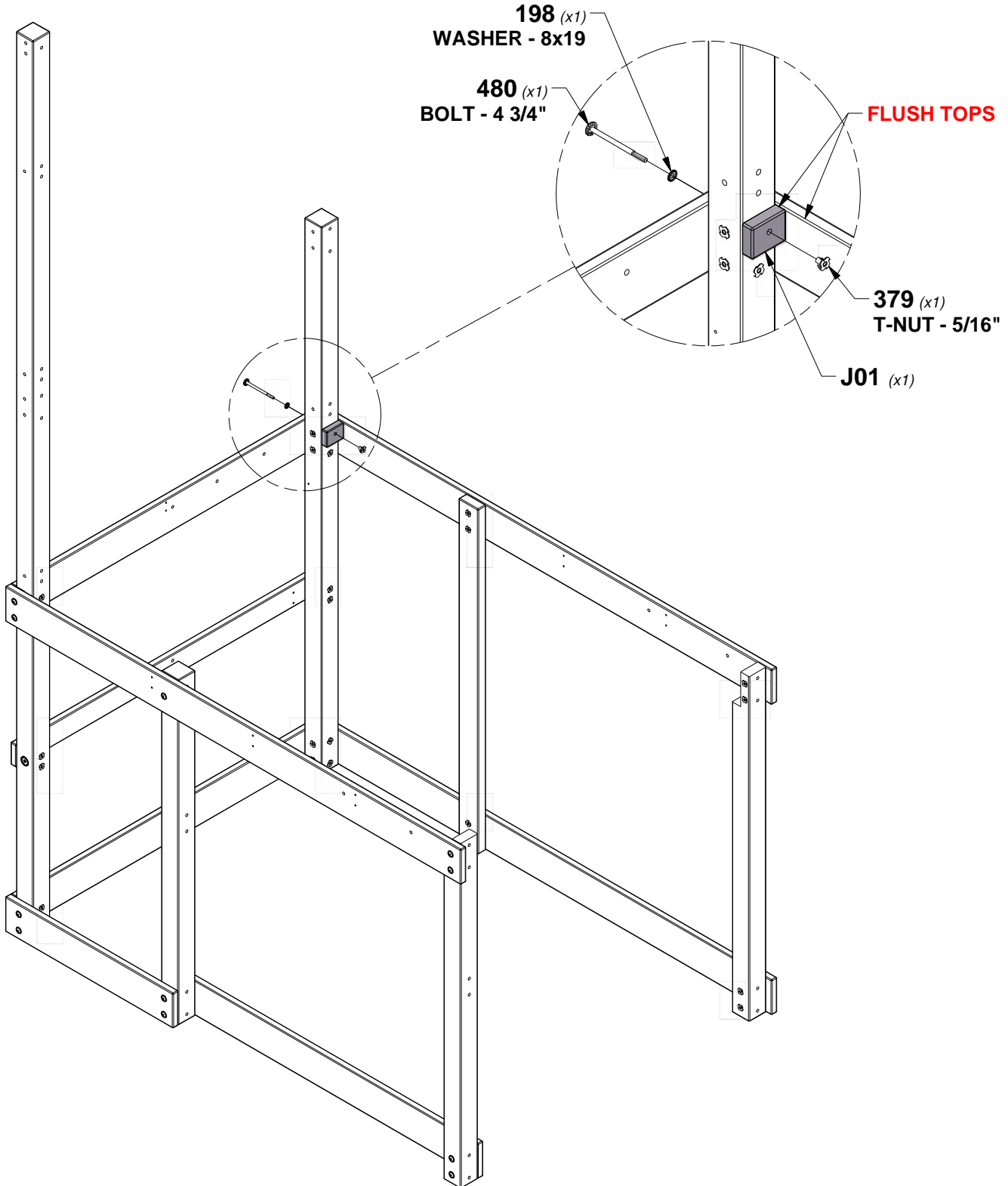

# STEP 9 - FORT ASSEMBLY

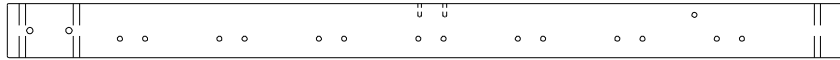

**E01 POST - W4L17702**  
 (x1) 1 3/8"x3 3/8"x52 3/8" (36x86x1330)

QTY	PART NUMBER	DESCRIPTION
2	H100197	LAG SCREW WH 5/16x2-1/2 BLK
5	H100198	WASHER LOCK EXT 8x19 BLK
3	H100379	T-NUT 5/16 BLK
3	H100513	BOLT WH 5/16x4 1/4 BLK

**TIP:**  
**INSTALL T-NUTS IN WOOD FIRST**

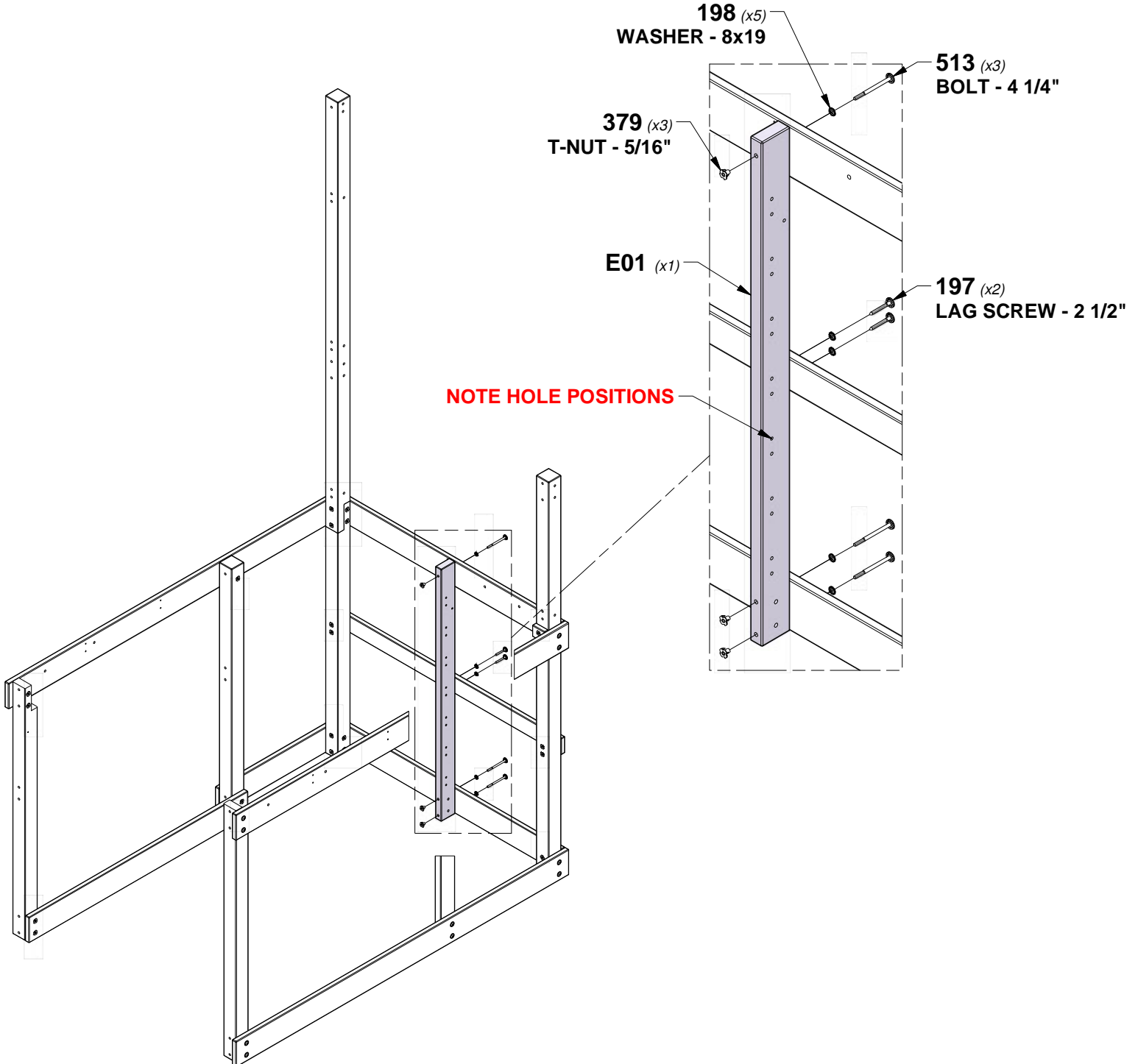

# STEP 10 - FORT ASSEMBLY

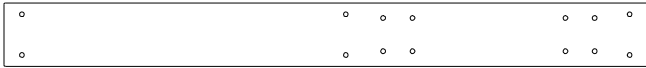

**G02 GROUND BOARD - W4L17699**  
 (x1) 1"x5 1/4"x53 5/8" (24x134x1363)

QTY	PART NUMBER	DESCRIPTION
4	H100198	WASHER LOCK EXT 8x19 BLK
4	H100379	T-NUT 5/16 BLK
4	H100415	BOLT WH 5/16x3 3/4 BLK

**TIP:**  
**INSTALL T-NUTS IN WOOD FIRST**

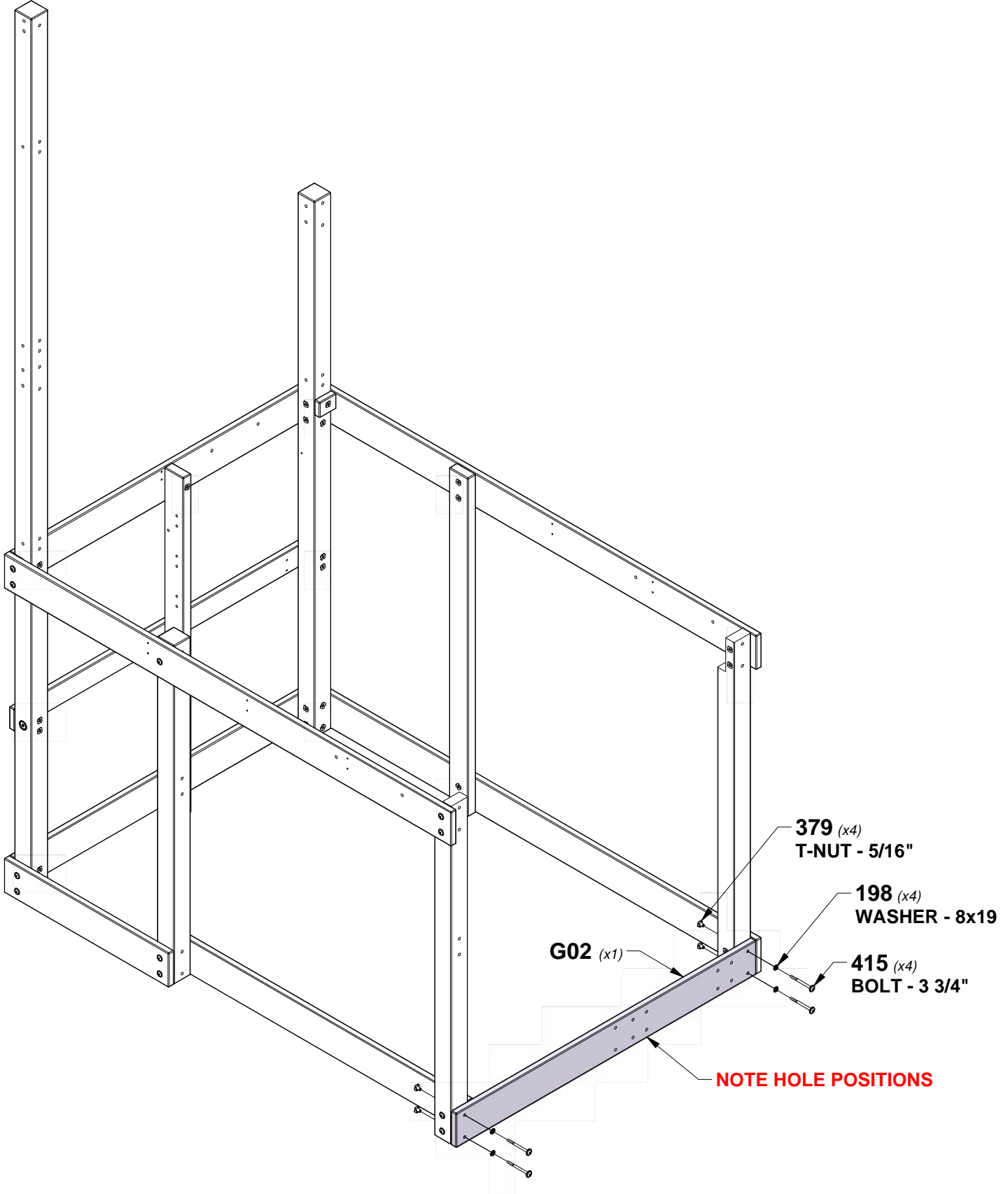

# STEP 11 - FORT ASSEMBLY

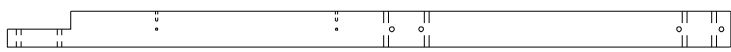

**B05 POST - W4L17696**  
(x1) 3"x3"x60 3/8" (76x76x1532)

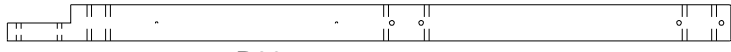

**B06 POST - W4L17697**  
(x1) 3"x3"x60 3/8" (76x76x1532)

QTY	PART NUMBER	DESCRIPTION
2	H100198	WASHER LOCK EXT 8x19 BLK
2	H100379	T-NUT 5/16 BLK
2	H100415	BOLT WH 5/16x3 3/4 BLK



**G05 FLOOR RAIL - W4L17704**  
(x1) 1"x5 1/4"x53 5/8" (24x134x1363)

**TIP:**  
**INSTALL T-NUTS IN WOOD FIRST**

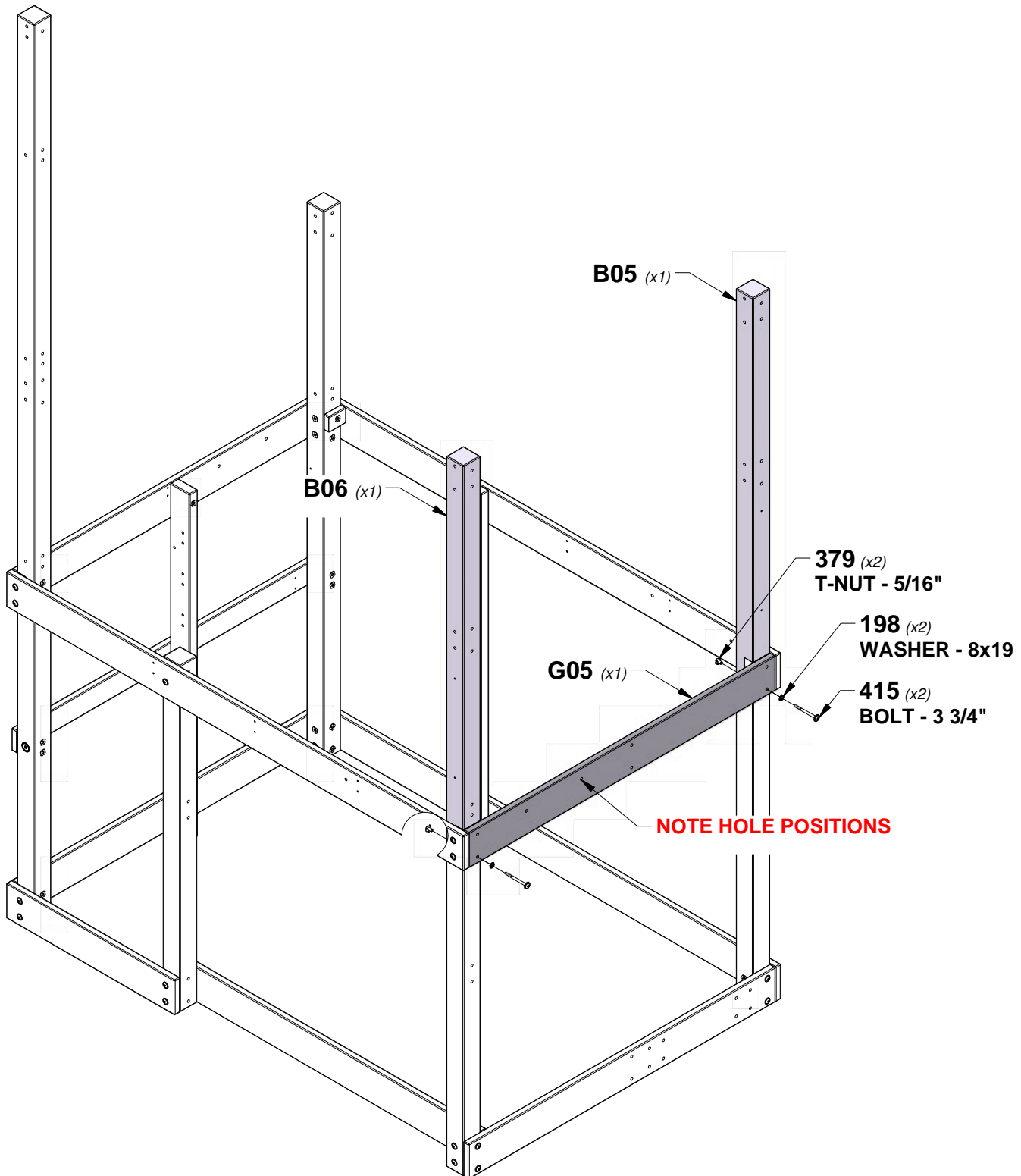

# STEP 12 - FORT ASSEMBLY

QTY	PART NUMBER	DESCRIPTION
2	H100198	WASHER LOCK EXT 8x19 BLK
2	H100379	T-NUT 5/16 BLK
2	H100480	BOLT WH 5/16x4 3/4 BLK

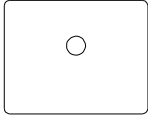

**J01 FLOOR SUPPORT - W4L17729**  
(x2) 15/16"x3"x2 3/8" (24x76x60)

**TIP:**  
**INSTALL T-NUTS IN WOOD FIRST**

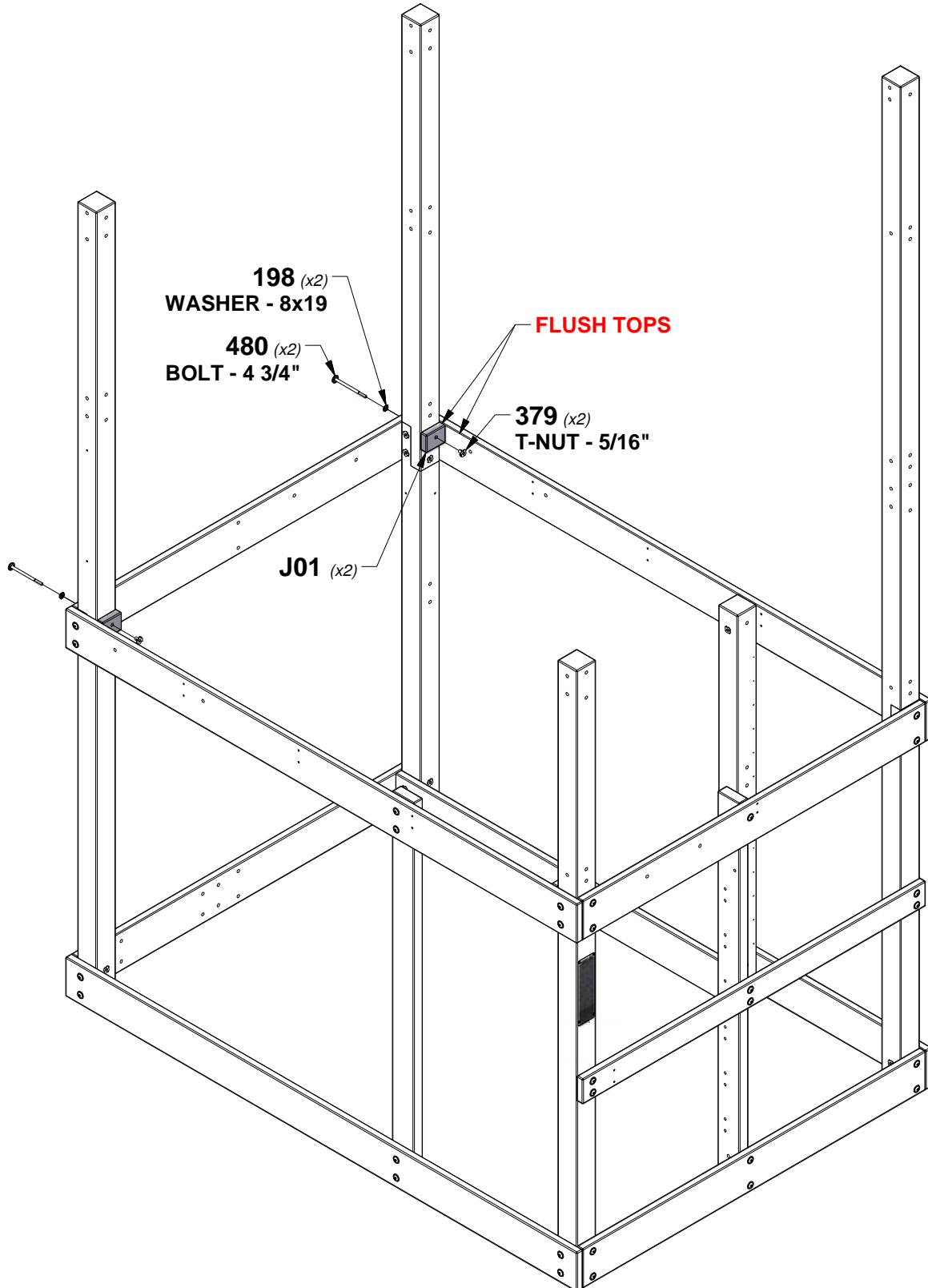



# STEP 13 - FORT ASSEMBLY

QTY	PART NUMBER	DESCRIPTION
4	H100198	WASHER LOCK EXT 8x19 BLK
4	H100205	BOLT WH 5/16x2 1/4 BLK
4	H100379	T-NUT 5/16 BLK



**E02 POST - W4L17707**  
(x1) 1 3/8"x3 3/8"x52 3/8" (36x86x1330)

**NOTE PILOT HOLE POSITION**

**TIP:**  
**INSTALL T-NUTS IN WOOD FIRST**

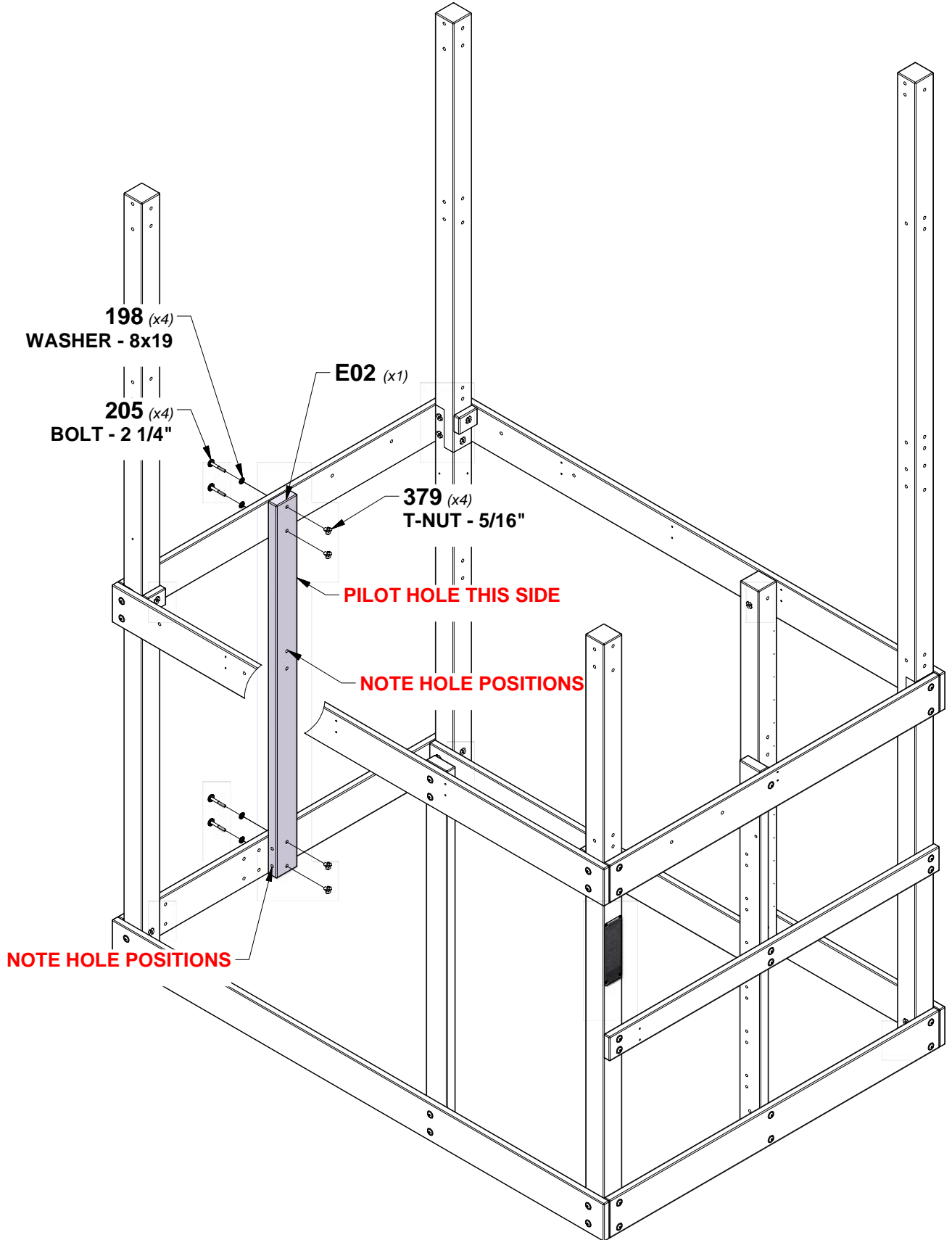

# STEP 14 - FORT ASSEMBLY



**D03 MID RAIL - W4L17713**  
 (x1) 1 3/8"x5 1/4"x53 5/8" (36x134x1363)

QTY	PART NUMBER	DESCRIPTION
4	H100198	WASHER LOCK EXT 8x19 BLK
4	H100379	T-NUT 5/16 BLK
4	H100513	BOLT WH 5/16x4 1/4 BLK

**TIP:**  
**INSTALL T-NUTS IN WOOD FIRST**

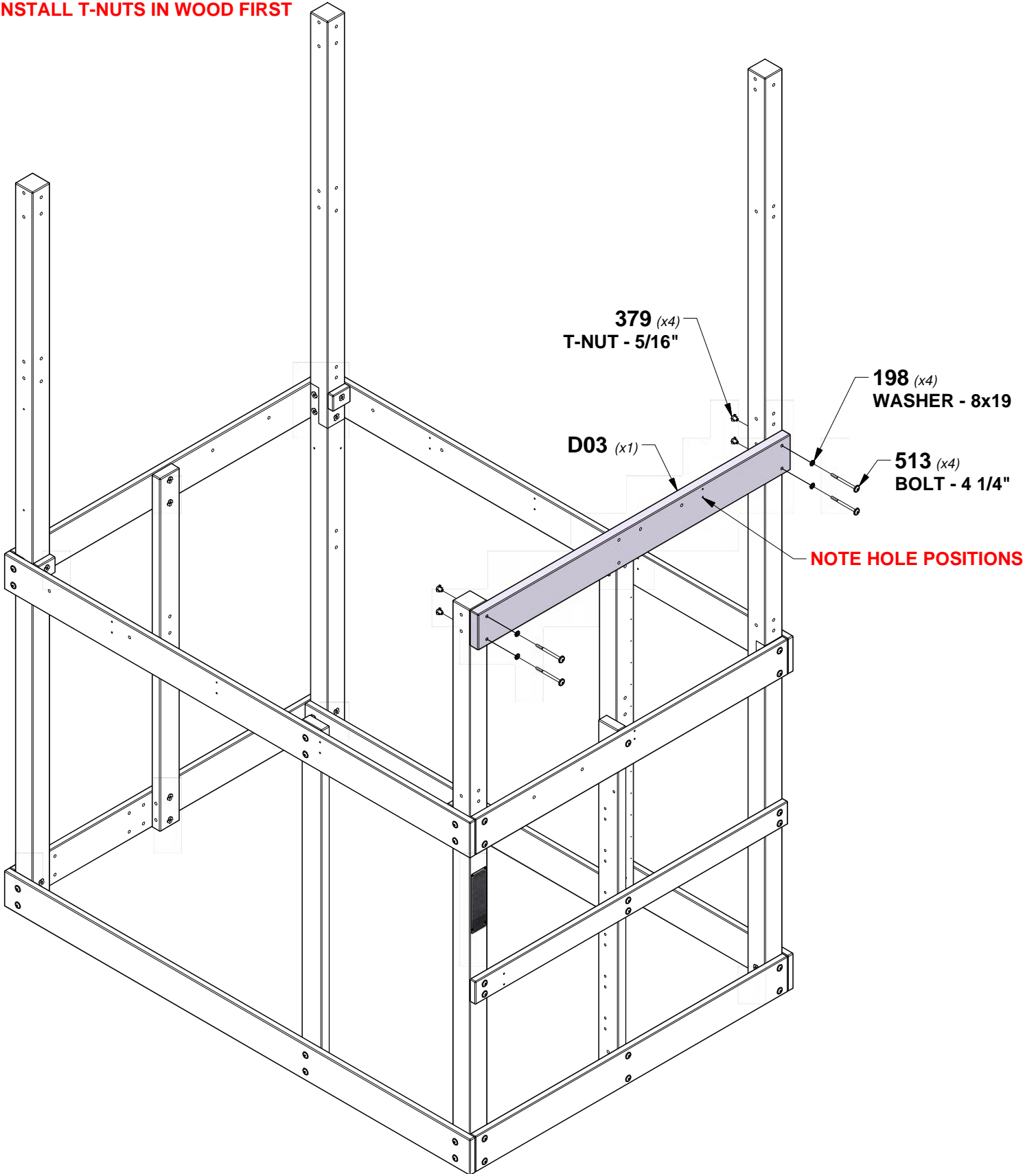

# STEP 15 - FORT ASSEMBLY

QTY	PART NUMBER	DESCRIPTION
4	H100198	WASHER LOCK EXT 8x19 BLK
4	H100379	T-NUT 5/16 BLK
4	H100415	BOLT WH 5/16x3 3/4 BLK



**G14 MID RAIL - W4L17717**  
 (x1) 1"x5 1/4"x80 1/2" (24x134x2044)

**TIP:**  
**INSTALL T-NUTS IN WOOD FIRST**

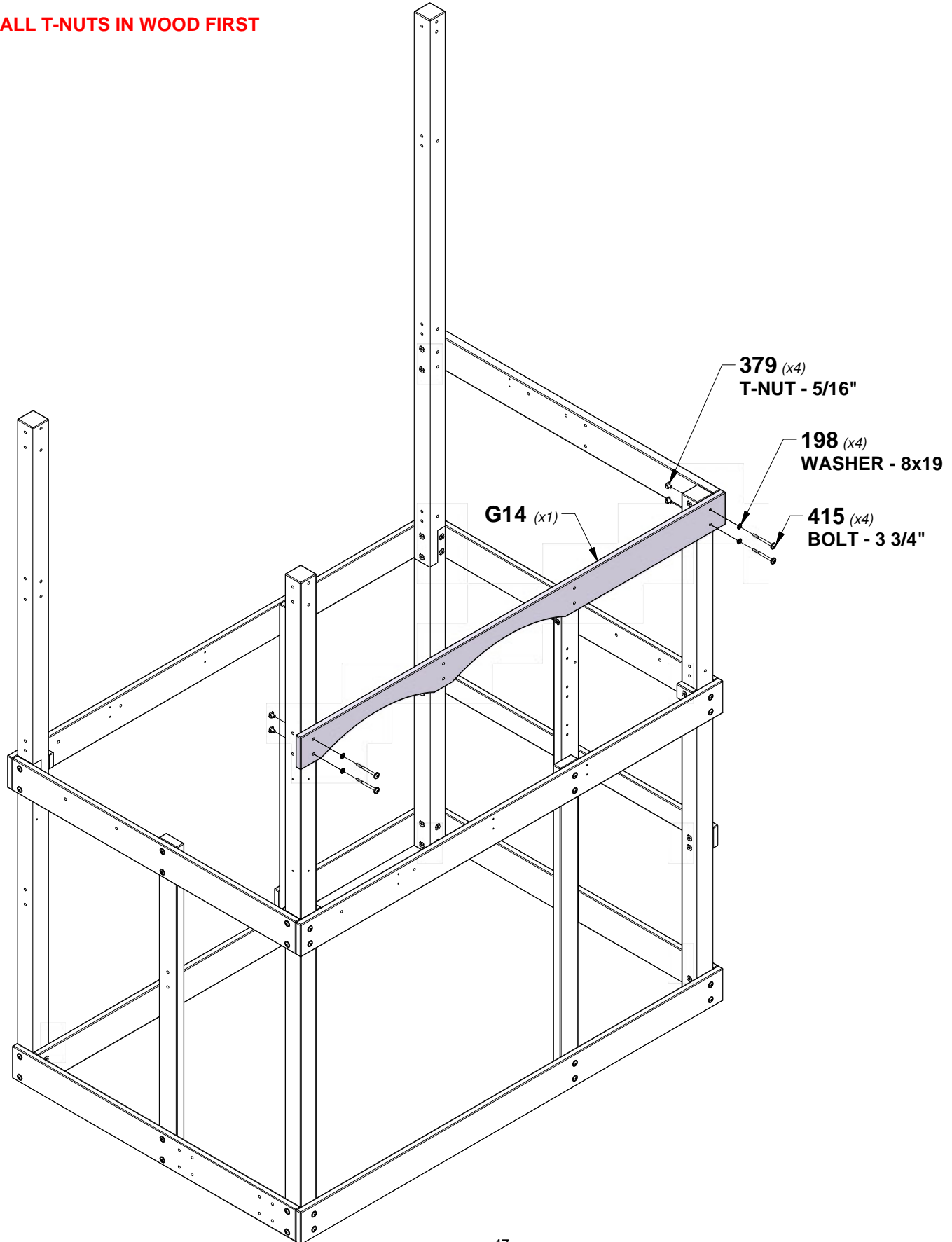

# STEP 16 - FORT ASSEMBLY

QTY	PART NUMBER	DESCRIPTION
4	H100198	WASHER LOCK EXT 8x19 BLK
4	H100379	T-NUT 5/16 BLK
4	H100415	BOLT WH 5/16x3 3/4 BLK

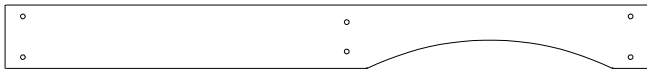

**G13 MID RAIL - W4L17716**  
 (x1) 1"x5 1/4"x53 5/8" (24x134x1363)

**TIP:**  
**INSTALL T-NUTS IN WOOD FIRST**

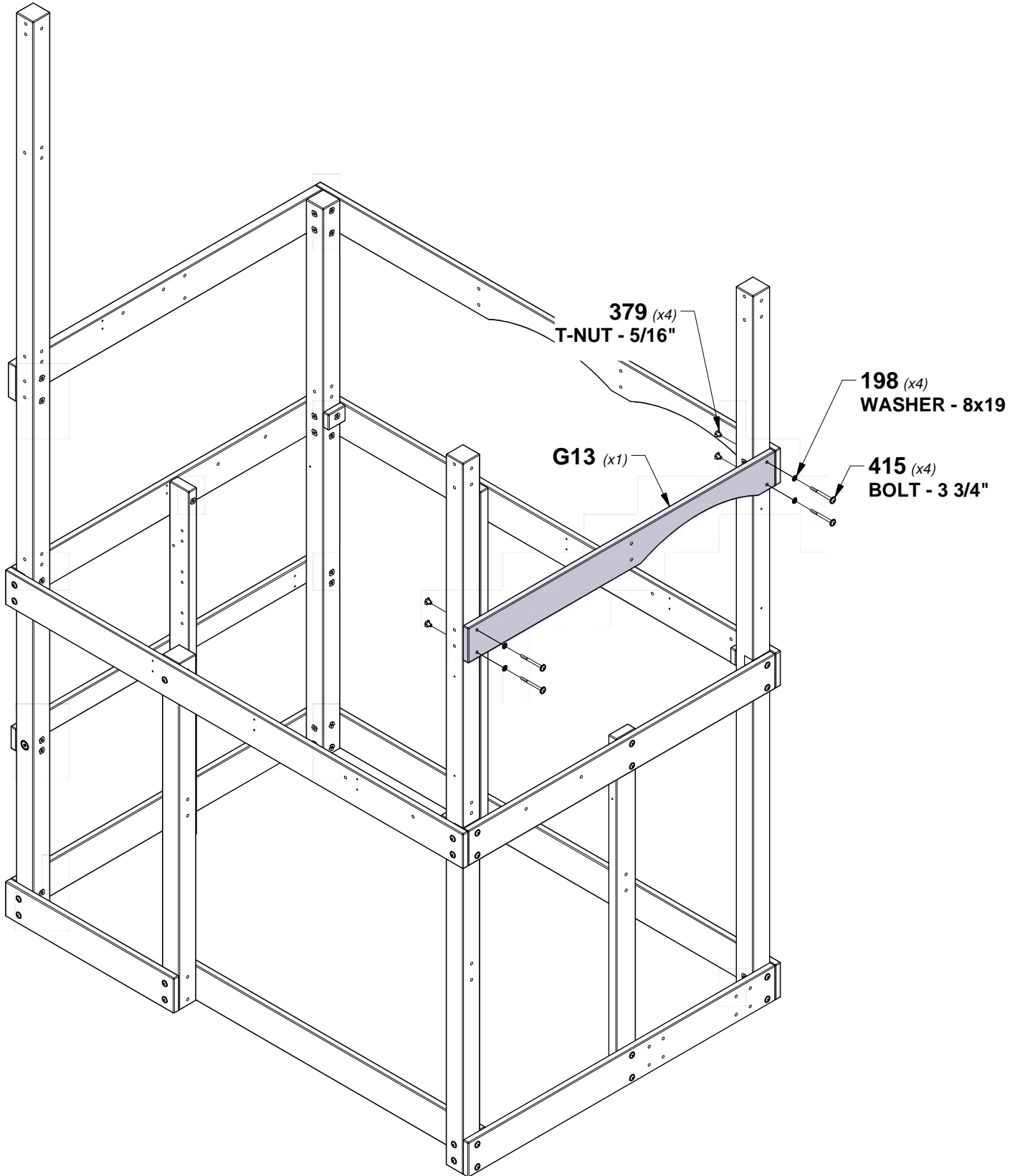

# STEP 17 - FORT ASSEMBLY

QTY	PART NUMBER	DESCRIPTION
4	H100198	WASHER LOCK EXT 8x19 BLK
4	H100379	T-NUT 5/16 BLK
3	H100415	BOLT WH 5/16x3 3/4 BLK
1	H100480	BOLT WH 5/16x4 3/4 BLK

**J01 FLOOR SUPPORT - W4L17729**  
 (x1) 15/16"x3"x2 3/8" (24x76x60)



**G15 MID RAIL - W4L17718**  
 (x1) 1"x5 1/4"x80 1/2" (24x134x2044)

**TIP:**  
**INSTALL T-NUTS IN WOOD FIRST**

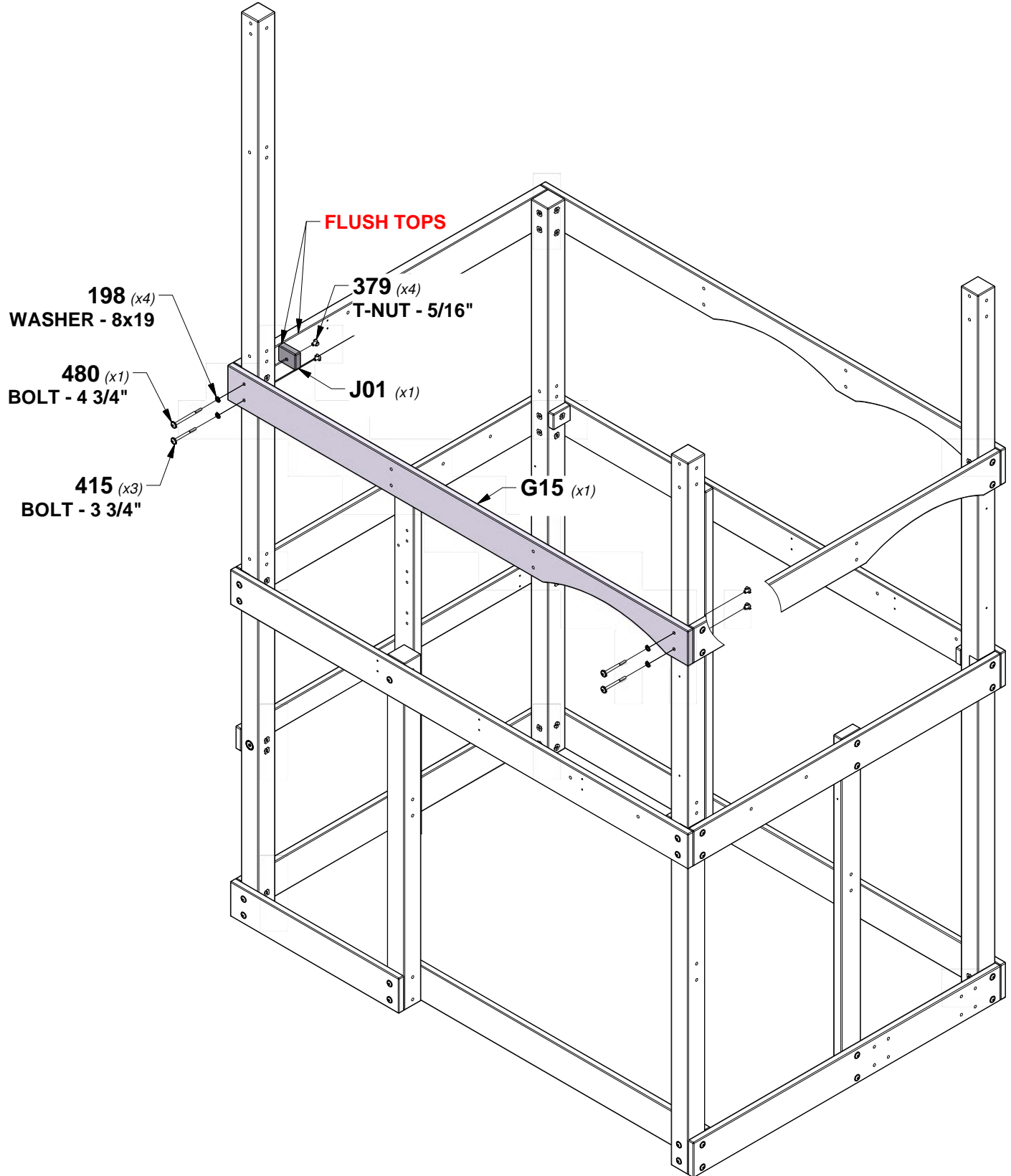

# STEP 18 - FORT ASSEMBLY



**G10 GROUND BOARD - W4L17711**  
(x1) 1"x5 1/4"x78 1/8" (24x134x1984)



**G12 GROUND BOARD - W4L17715**  
(x1) 1"x5 1/4"x25 7/8" (24x134x657)

QTY	PART NUMBER	DESCRIPTION
6	H100198	WASHER LOCK EXT 8x19 BLK
2	H100201	SCREW PFH 8x2-1/2 BLK
2	H100205	BOLT WH 5/16x2-1/4 BLK
6	H100379	T-NUT 5/16 BLK
2	H100415	BOLT WH 5/16x3 3/4 BLK
2	H100513	BOLT WH 5/16x4 1/4 BLK

**TIP:**  
**INSTALL T-NUTS IN WOOD FIRST**

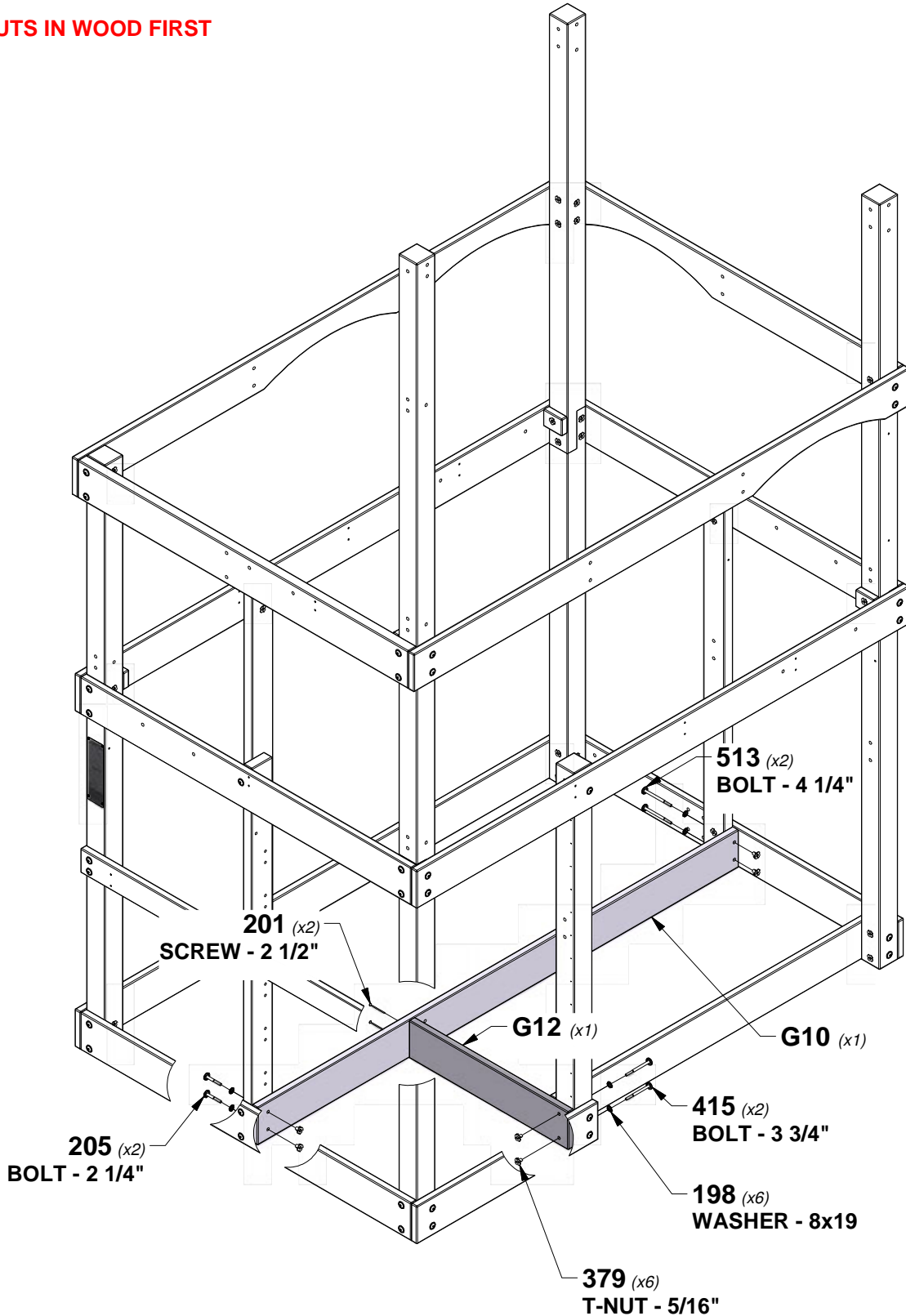

# STEP 19 - FORT ASSEMBLY

QTY	PART NUMBER	DESCRIPTION
1	H100198	WASHER LOCK EXT 8x19 BLK
12	H100201	SCREW PFH 8x2-1/2 BLK
1	H100379	T-NUT 5/16 BLK
1	H100513	BOLT WH 5/16x4 1/4 BLK

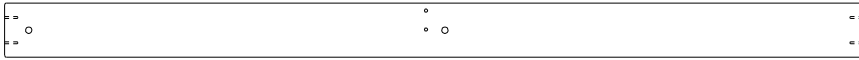

**E04 FLOOR JOIST - W4L17722**  
(x1) 1 3/8"x3 3/8"x53 5/8" (36x86x1363)



**E05 FLOOR JOIST - W4L17723**  
(x2) 1 3/8"x3 3/8"x53 5/8" (36x86x1363)

**TIP:**  
**INSTALL T-NUTS IN WOOD FIRST**

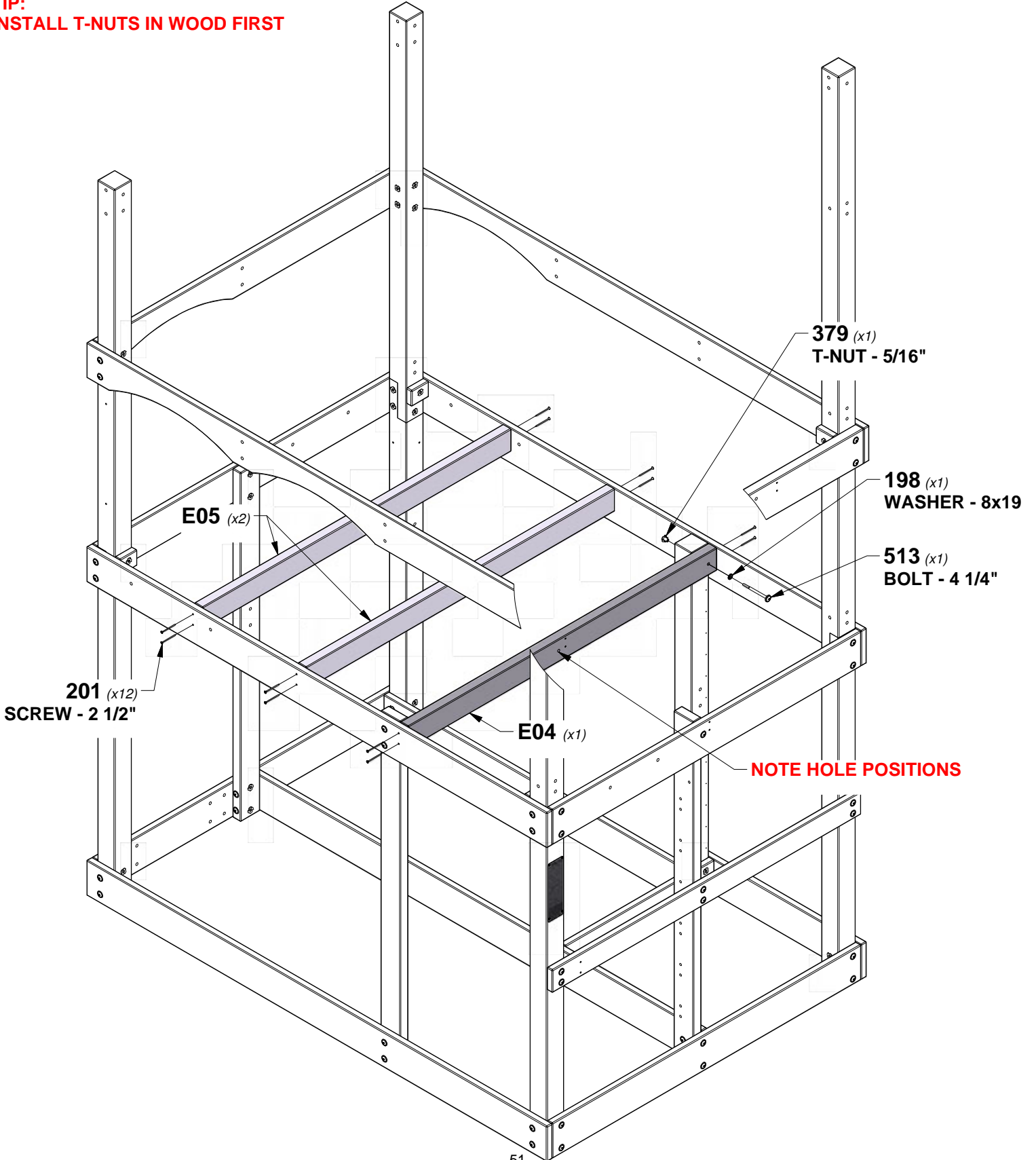

# STEP 20 - FORT ASSEMBLY

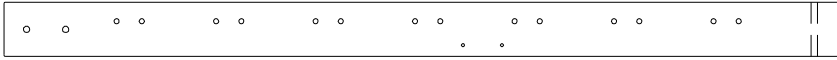

**E03 POST - W4L17712**  
(x1) 1 3/8"x3 3/8"x52 3/8" (36x86x1330)

QTY	PART NUMBER	DESCRIPTION
3	H100198	WASHER LOCK EXT 8x19 BLK
2	H100205	BOLT WH 5/16x2-1/4 BLK
3	H100379	T-NUT 5/16 BLK
1	H100480	BOLT WH 5/16x4 3/4 BLK

**TIP:**  
INSTALL T-NUTS IN WOOD FIRST

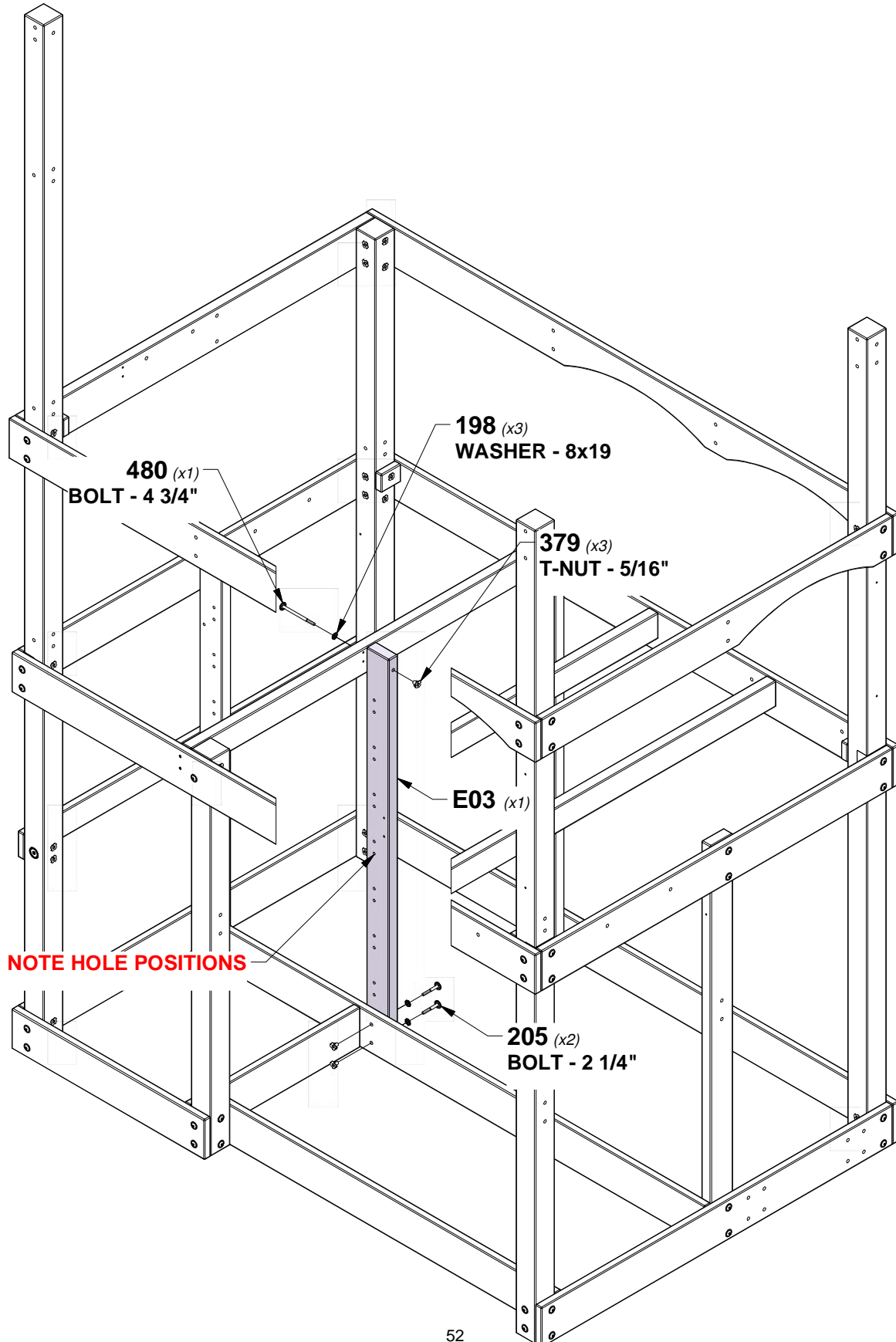



# STEP 21 - FORT ASSEMBLY

QTY	PART NUMBER	DESCRIPTION
64	H100086	SCREW PFH 8x1-1/2"



**M02 FLOOR BOARD - W4L17714**  
(x16) 5/8"x3 3/8"x23 7/8" (16x86x605)

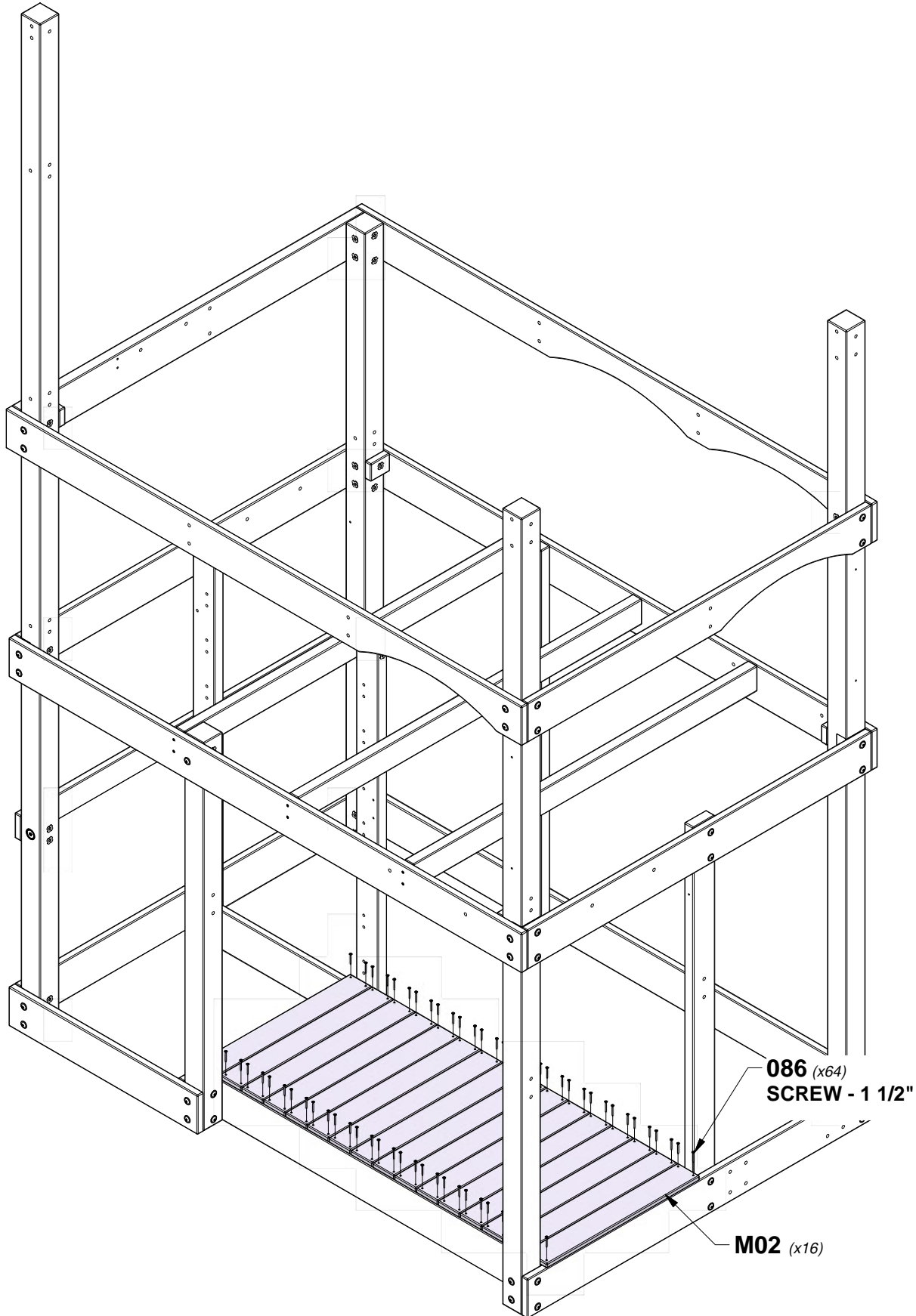

# STEP 22 - FORT ASSEMBLY

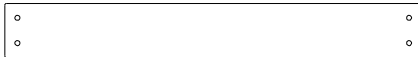

**H02 LADDER RUNG - W4L17724**  
(x7) 1"x3 3/8"x26 1/8" (24x86x662)



**H12 FLOOR JOIST - W4L17979**  
(x1) 1"x3 3/8"x24 1/8" (24x86x612)

QTY	PART NUMBER	DESCRIPTION
2	H100201	SCREW PFH 8x2-1/2 BLK
2	H100362	SCREW PFH 8x3 BLK
28	H100398	T-NUT 1/4 BLK
28	H100405	WASHER LOCK EXT 6x15 BLK
28	H100567	BOLT WH 1/4x2-1/4 BLK

**TIP:**  
**INSTALL T-NUTS IN WOOD FIRST**

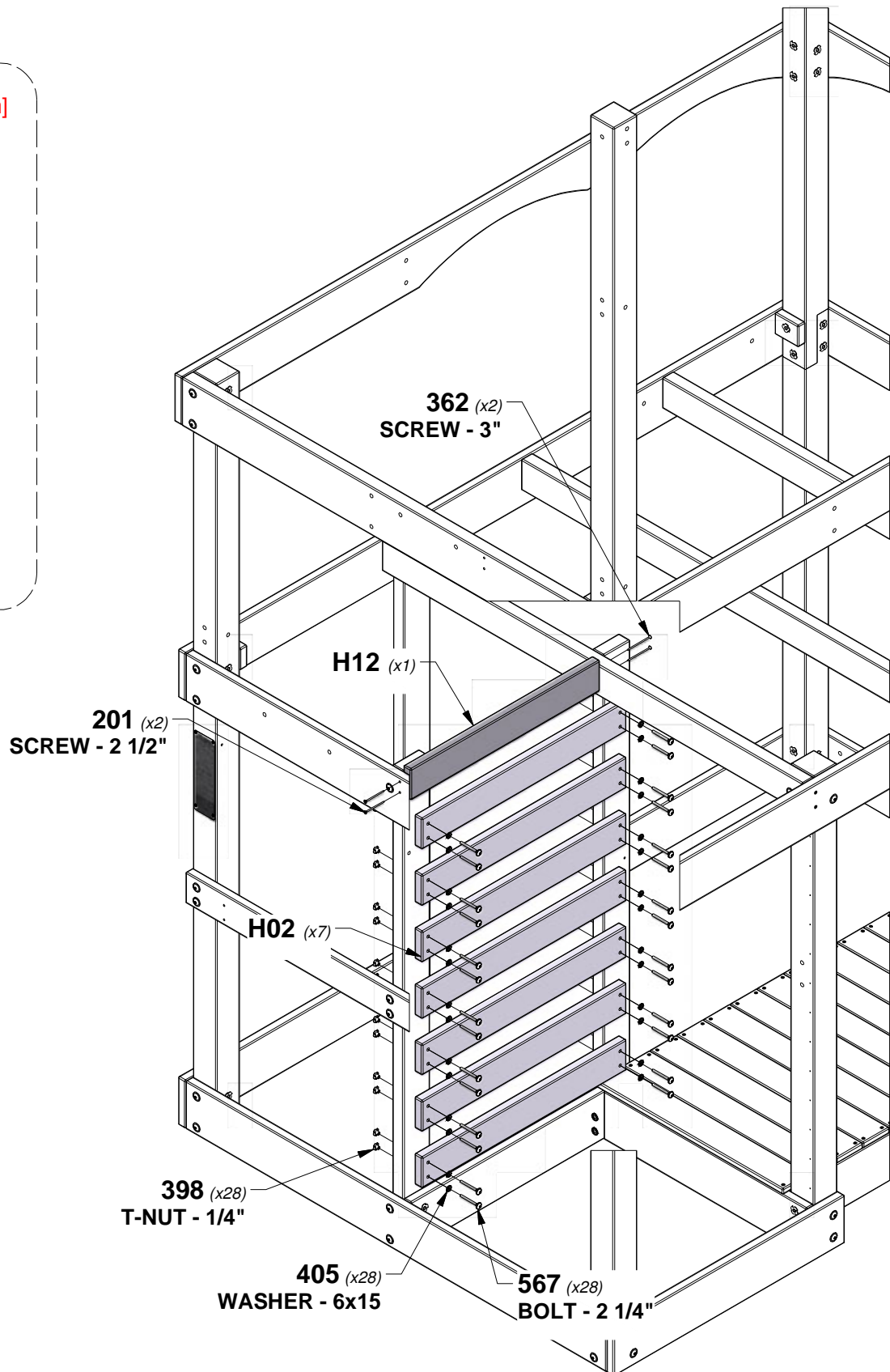
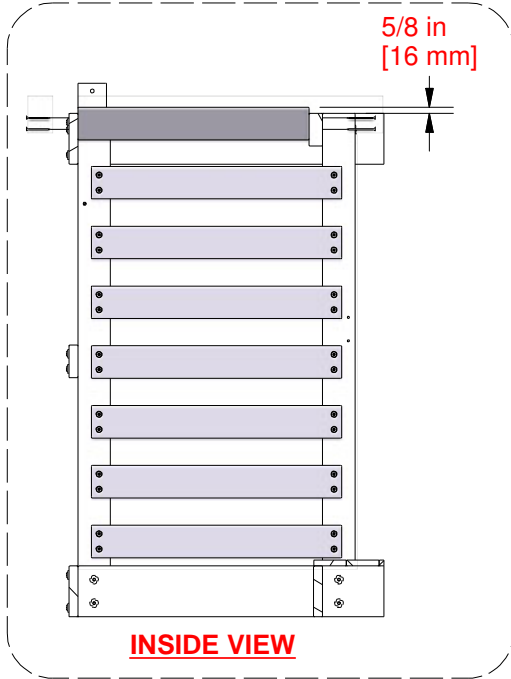

# STEP 23 - FORT ASSEMBLY



**E06 ANGLE BRACE - W4L17727**  
(x4) 1 7/16"x3 3/8"x13 3/4" (36x86x350)

QTY	PART NUMBER	DESCRIPTION
4	H100198	WASHER LOCK EXT 8x19 BLK
4	H100205	BOLT WH 5/16x2-1/4 BLK
4	H100379	T-NUT 5/16 BLK
1	H100398	T-NUT 1/4 BLK
4	H100405	WASHER LOCK EXT 6x15 BLK
3	H100487	LAG SCREW WH 1/4x2 BLK
1	H100567	BOLT WH 1/4x2-1/4 BLK

**TIP:**  
INSTALL T-NUTS IN WOOD FIRST

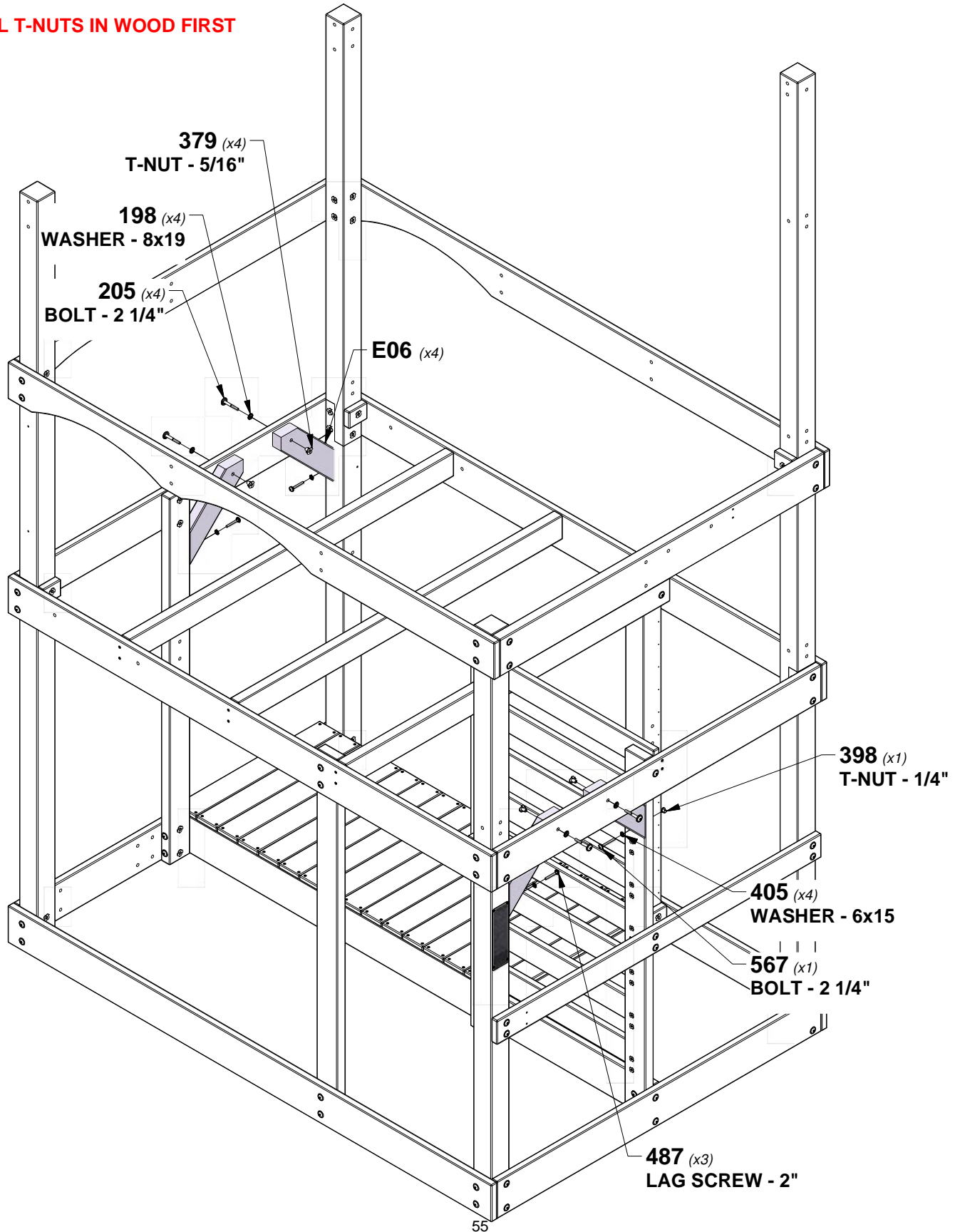

# STEP 24A - FORT ASSEMBLY

QTY	PART NUMBER	DESCRIPTION
32	H100392	SCREW PWH 8x3/4 BLK

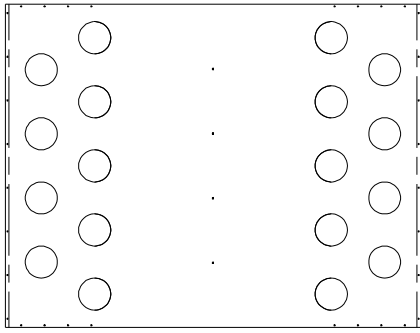

**A6P00557**  
*(x1)* TUNNEL

**TIP:**  
PLACING THE TUNNEL OUT IN THE SUN MAKES IT EASIER TO FORM.

**TIP:**  
USING AN 1/8 in [3 mm] DRILL BIT,  
PRE-DRILL PILOT HOLES FOR H100392 SCREWS.

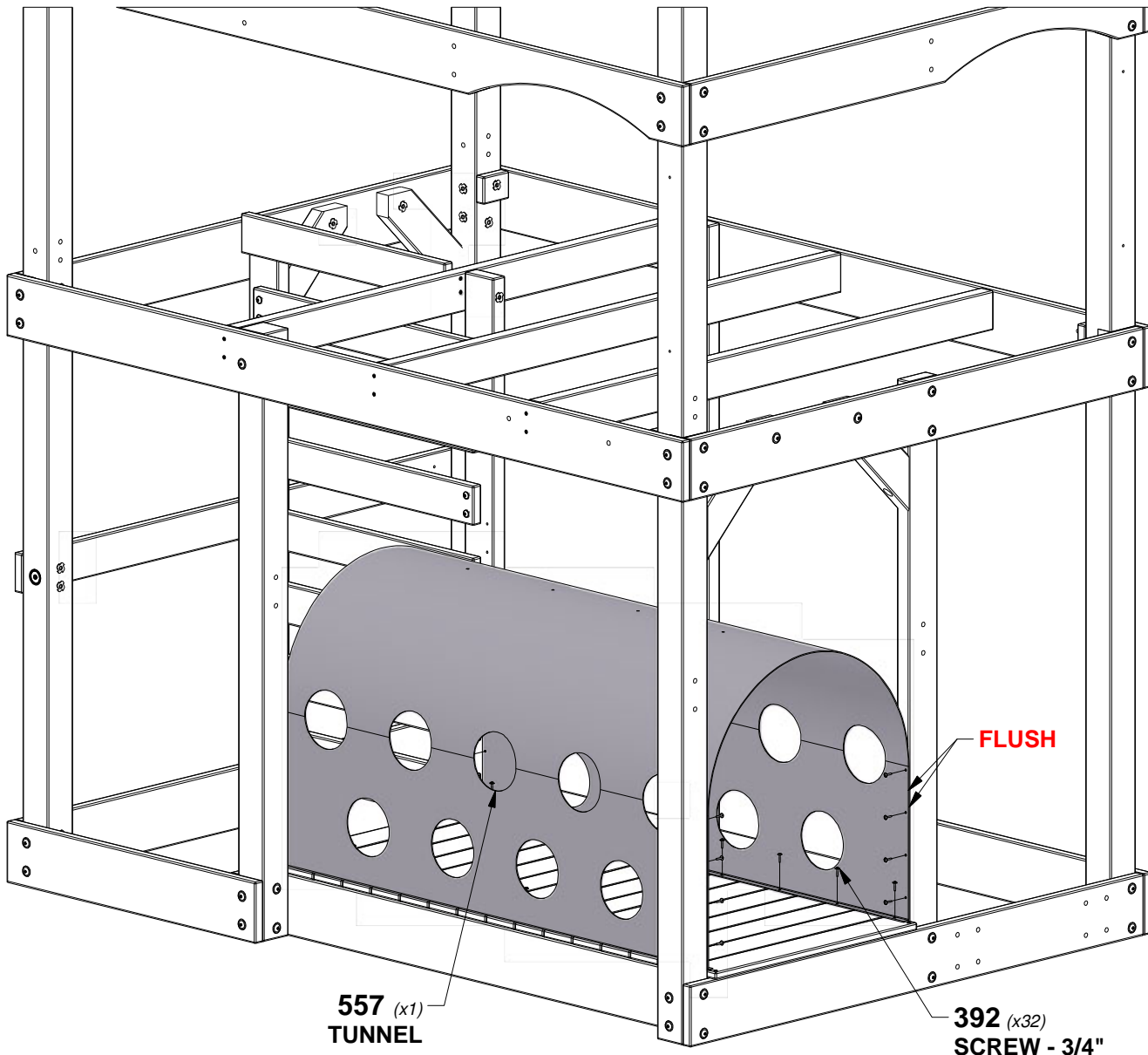
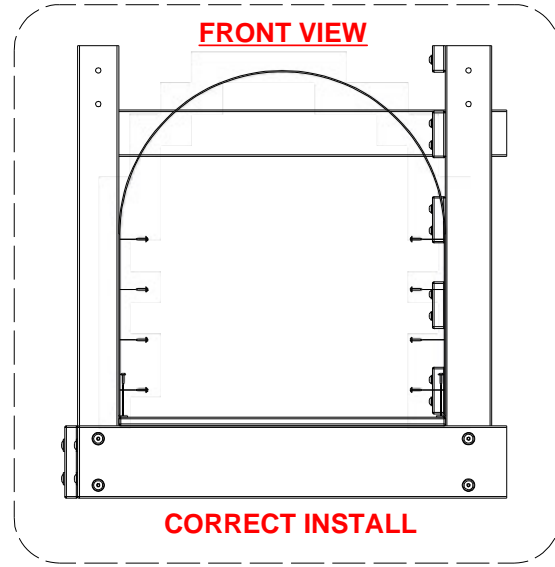

**557** *(x1)*  
TUNNEL

**392** *(x32)*  
SCREW - 3/4"

# STEP 24B - FORT ASSEMBLY

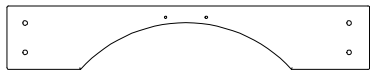

**D01 TUNNEL RAIL - W4L17725**  
(x1) 1 3/8"x5 1/4"x30 1/4" (36x134x767)

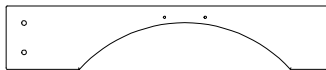

**D02 TUNNEL RAIL - W4L17726**  
(x1) 1 3/8"x5 1/4"x26 3/4" (36x134x681)



**G19 SUPPORT BOARD - W4L17966**  
(x1) 1"x5 1/4"x48 1/4" (24x134x1226)

QTY	PART NUMBER	DESCRIPTION
6	H100198	WASHER LOCK EXT 8x19 BLK
2	H100201	SCREW PFH 8x2-1/2 BLK
4	H100362	SCREW PFH 8x3 BLK
2	H100378	BOLT WH 5/16x1 3/4 BLK
6	H100379	T-NUT 5/16 BLK
14	H100392	SCREW PWH 8x3/4 BLK
4	H100484	BOLT WH 5/16x3 1/4 BLK

**TIP:**  
**INSTALL T-NUTS IN WOOD FIRST**

**TIP:**  
**USING AN 1/8 in [3 mm] DRILL BIT,**  
**PRE-DRILL PILOT HOLES FOR H100392 SCREWS.**

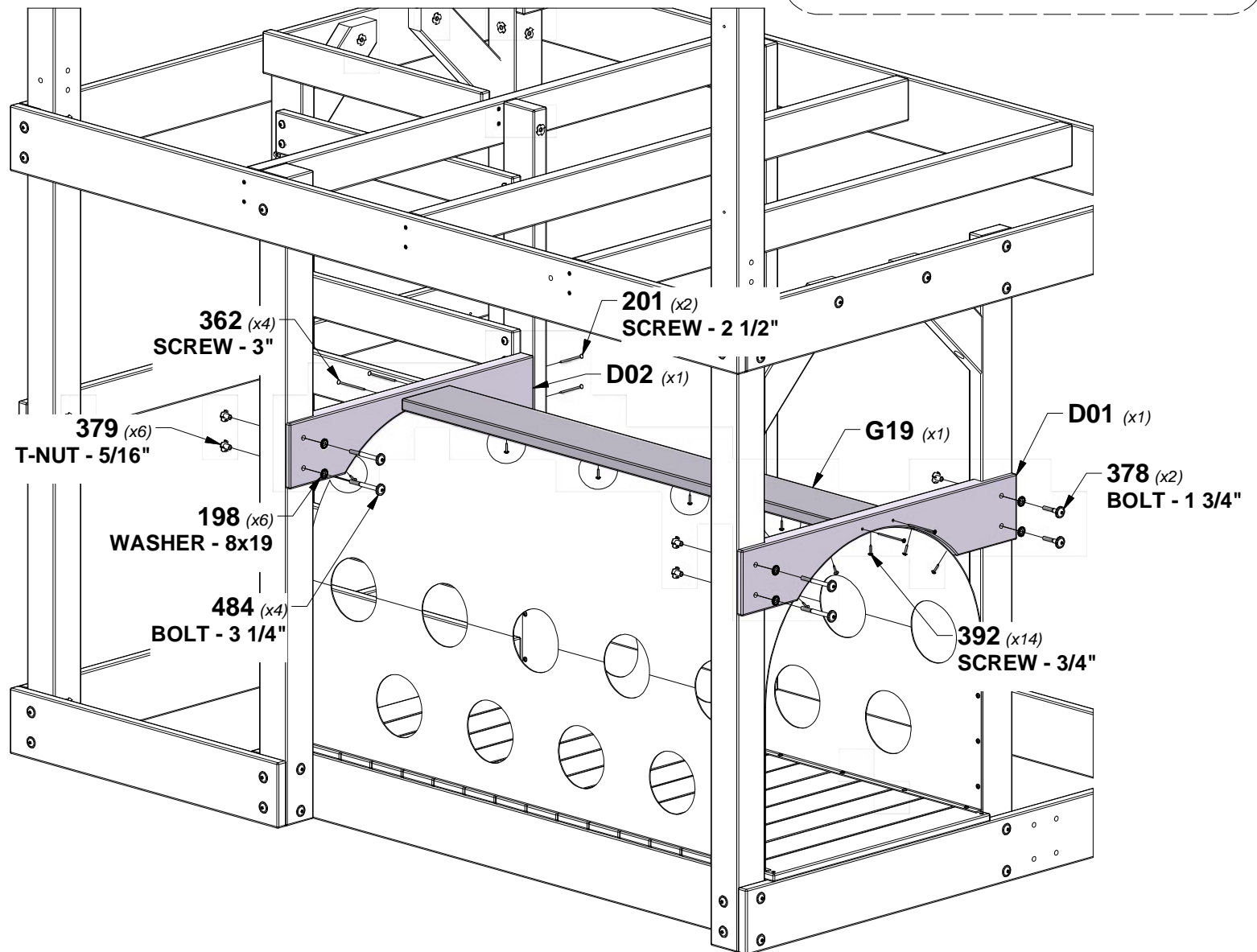
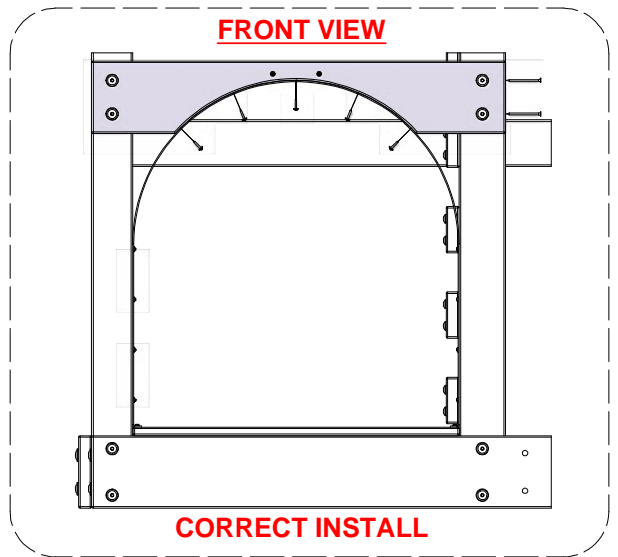



# STEP 25 - FORT ASSEMBLY

QTY	PART NUMBER	DESCRIPTION
109	H100086	SCREW PFH 8x1-1/2"



**M01 FLOOR BOARD - W4L17709**  
(x7) 5/8"x3 3/8"x80" (16x86x2032)

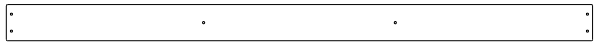

**M03 FLOOR BOARD - W4L17728**  
(x7) 5/8"x3 3/8"x55" (16x86x1396)

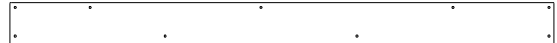

**Y01 FLOOR BOARD - W4L17730**  
(x1) 5/8"x3 7/8"x51" (16x100x1296)



**Y02 FLOOR BOARD - W4L17731**  
(x1) 5/8"x3 7/8"x72 1/8" (16x100x1832)

**NOTE:**  
ENSURE THAT PILOT HOLES ARE ALIGNED OVER FLOOR JOISTS.

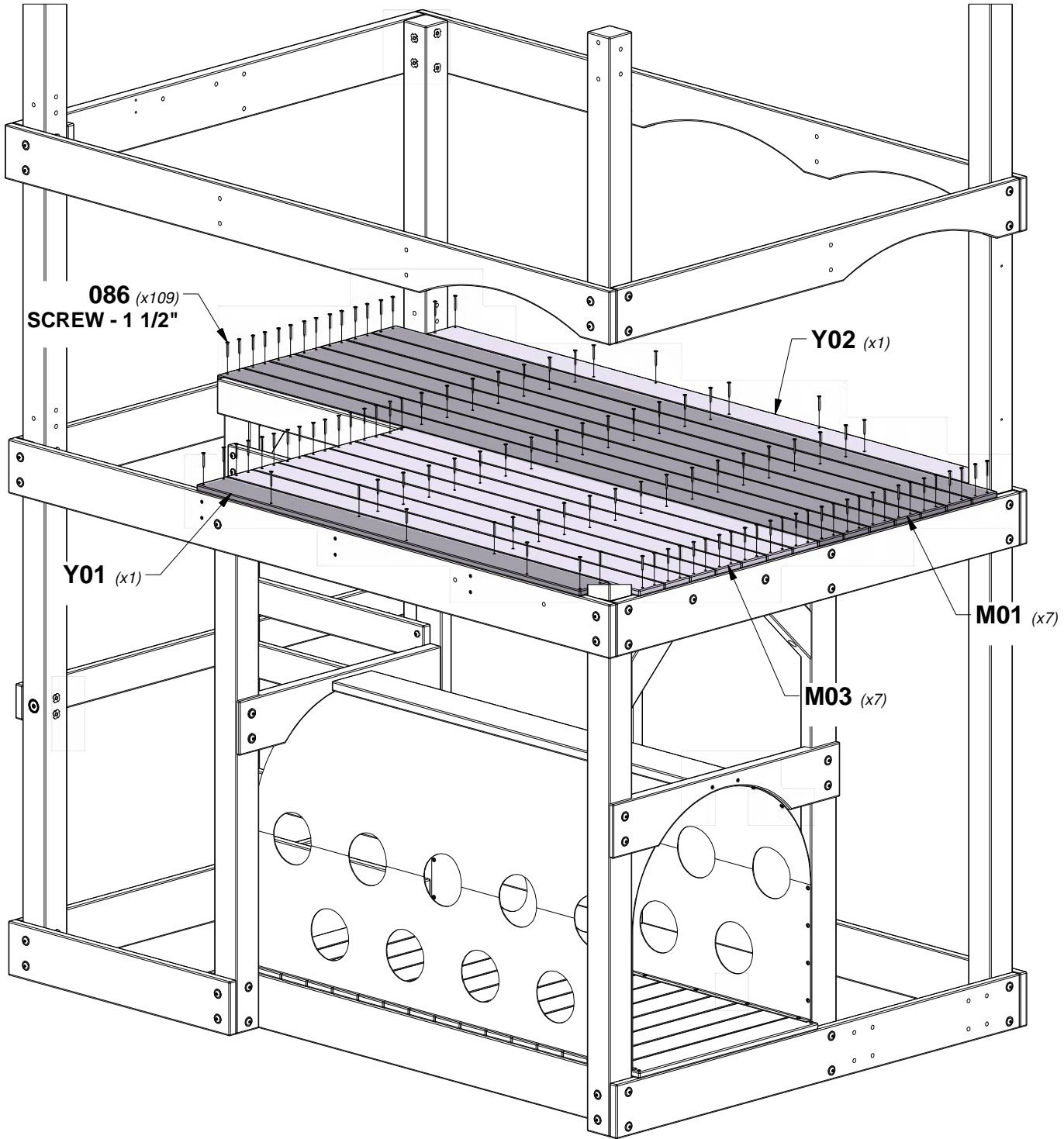

# STEP 26 - FORT ASSEMBLY

QTY	PART NUMBER	DESCRIPTION
2	H100198	WASHER LOCK EXT 8x19 BLK
2	H100378	BOLT WH 5/16x1 3/4 BLK
2	H100379	T-NUT 5/16 BLK

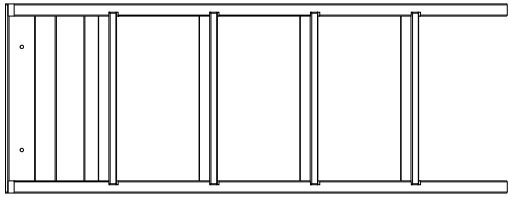

LADDER ASSEMBLY

**TIP:**  
INSTALL T-NUTS IN WOOD FIRST

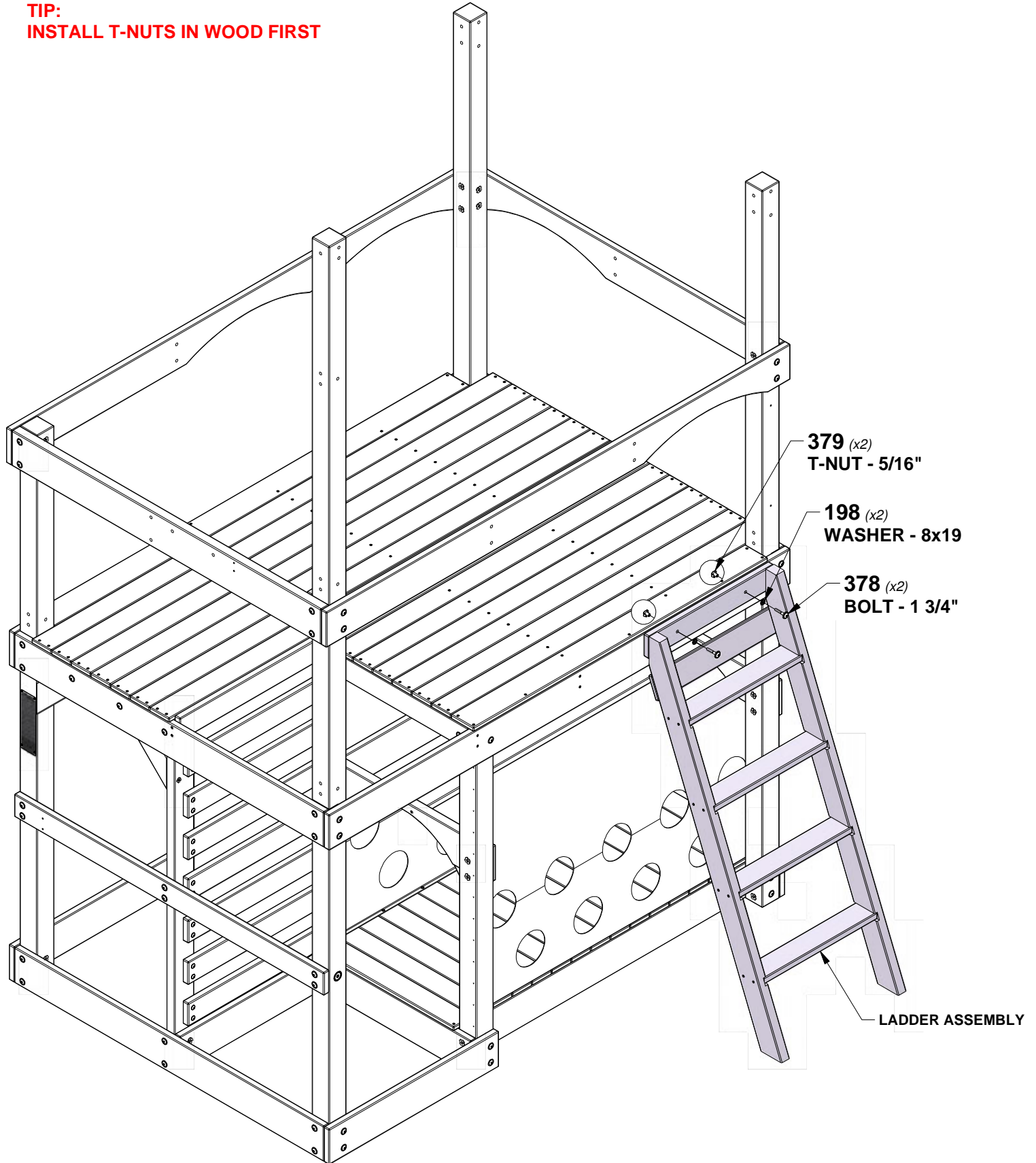

# STEP 27 - FORT ASSEMBLY

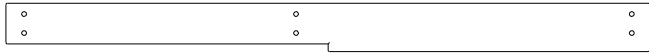

**AD01 WALL RAIL - W4L17756**  
 (x1) 1"x4"x53 5/8" (24x102x1363)

QTY	PART NUMBER	DESCRIPTION
4	H100198	WASHER LOCK EXT 8x19 BLK
4	H100379	T-NUT 5/16 BLK
4	H100415	BOLT WH 5/16x3 3/4 BLK

**TIP:**  
**INSTALL T-NUTS IN WOOD FIRST**

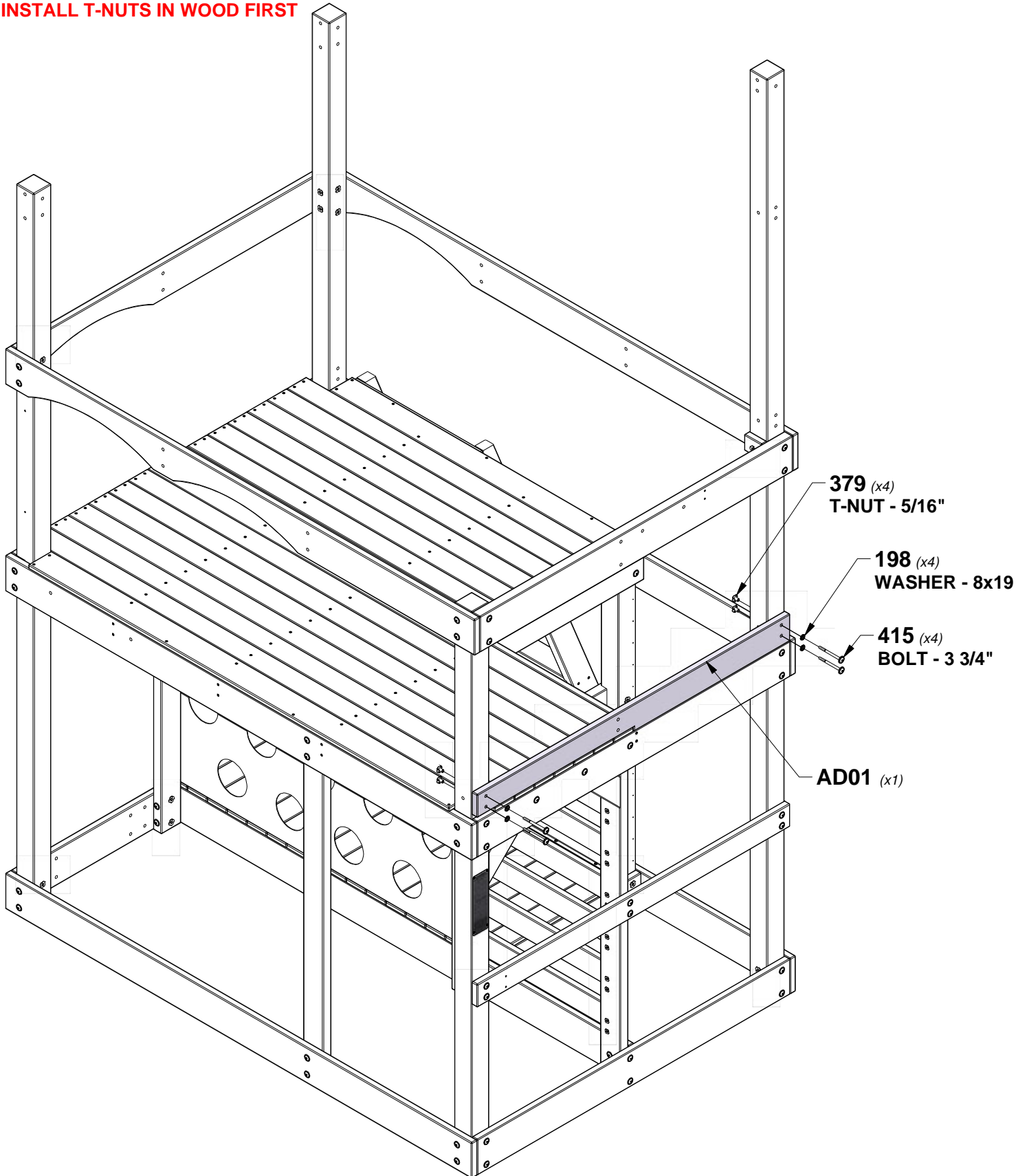

**379 (x4)**  
**T-NUT - 5/16"**

**198 (x4)**  
**WASHER - 8x19**

**415 (x4)**  
**BOLT - 3 3/4"**

**AD01 (x1)**



# STEP 28 - FORT ASSEMBLY

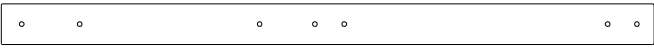

**H06 UPRIGHT - W4L17736**  
(x1) 1"x3 3/8"x54 3/8" (24x86x1382)

2 1/2 in  
[62 mm]



**H13 WALL RAIL - W4L17755**  
(x1) 1"x3 3/8"x29 7/8" (24x86x758)



**A4M01047 L BRACKET**  
(x2) 2.5x38x55x55



**E07 POST - W4L17734**  
(x1) 1 3/8"x3 3/8"x54 3/8" (36x86x1382)

QTY	PART NUMBER	DESCRIPTION
2	H100192	NUT BARREL WH 5/16x7/8 BLK
5	H100198	WASHER LOCK EXT 8x19 BLK
2	H100199	WASHER LOCK EXT 12x19 BLK
2	H100205	BOLT WH 5/16x2-1/4 BLK
2	H100378	BOLT WH 5/16x1 3/4 BLK
7	H100379	T-NUT 5/16 BLK
3	H100396	BOLT WH 5/16x1/2 BLK
1	H100415	BOLT WH 5/16x3 3/4 BLK
1	H100457	BOLT WH 5/16x2 BLK

**TIP:**  
INSTALL T-NUTS IN WOOD FIRST

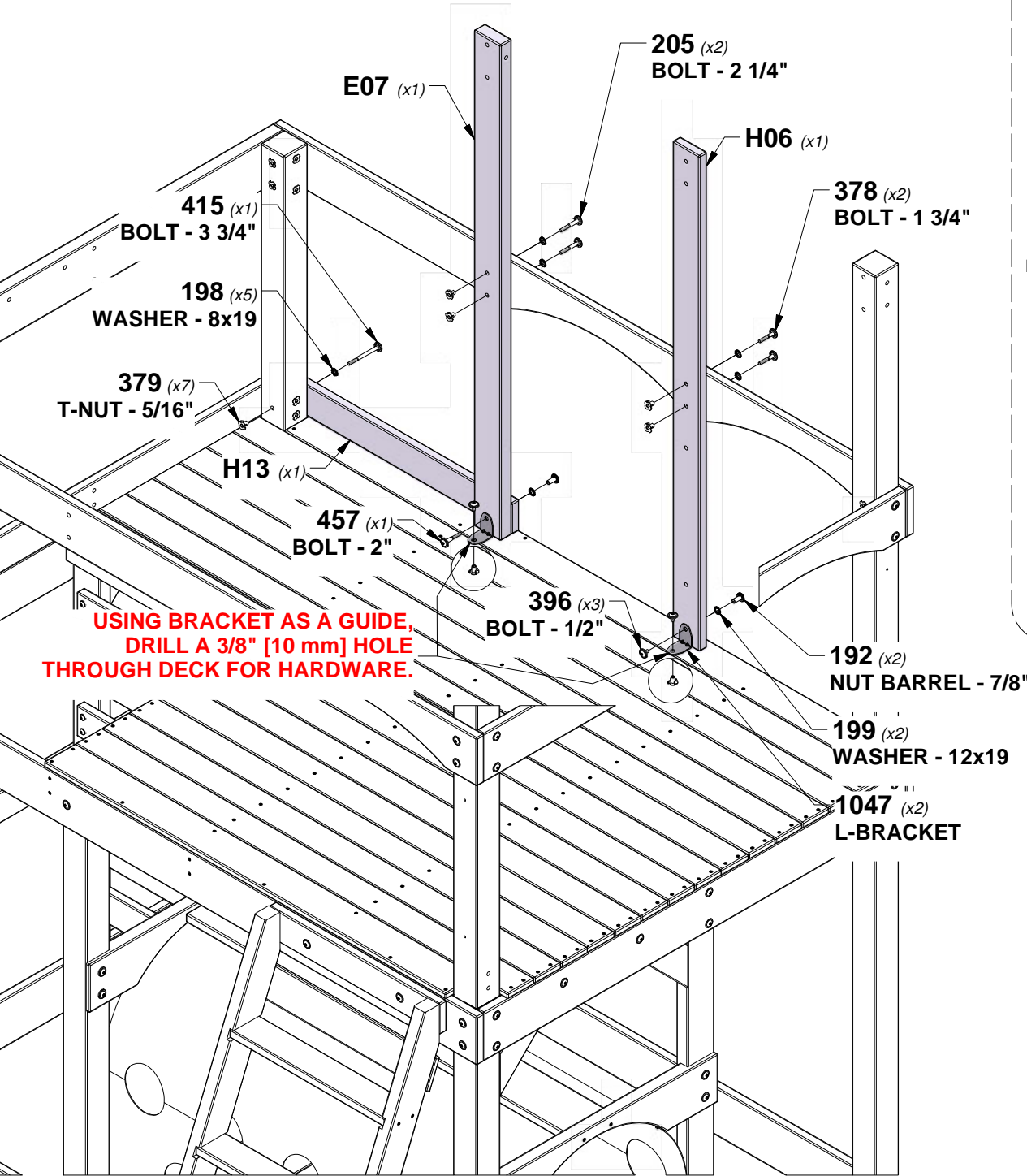
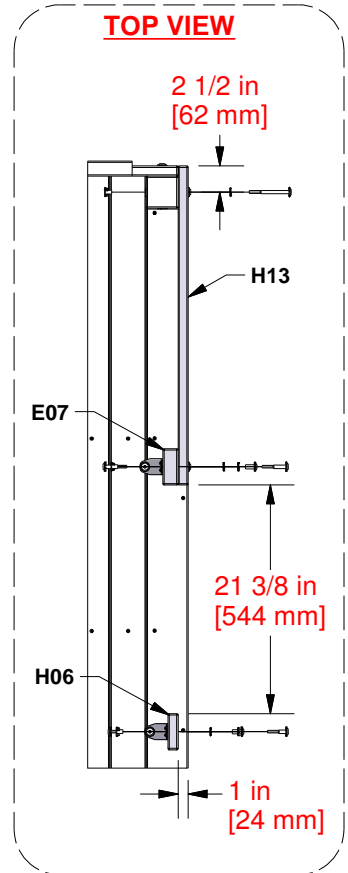

**USING BRACKET AS A GUIDE,  
DRILL A 3/8" [10 mm] HOLE  
THROUGH DECK FOR HARDWARE.**

# STEP 29 - FORT ASSEMBLY



**H04 UPRIGHT - W4L17732**  
(x1) 1"x3 3/8"x29 3/4" (24x86x756)



**H05 PICKET RAIL - W4L17733**  
(x1) 1"x3 3/8"x30 1/4" (24x86x767)



**A4M01047 L BRACKET**  
(x1) 2.5x38x55x55

QTY	PART NUMBER	DESCRIPTION
1	H100192	NUT BARREL WH 5/16x7/8 BLK
4	H100198	WASHER LOCK EXT 8x19 BLK
1	H100199	WASHER LOCK EXT 12x19 BLK
2	H100378	BOLT WH 5/16x1 3/4 BLK
5	H100379	T-NUT 5/16 BLK
1	H100396	BOLT WH 5/16x1/2 BLK
1	H100407	BOLT WH 5/16x1 1/2 BLK
2	H100415	BOLT WH 5/16x3 3/4 BLK

**TIP:**  
**INSTALL T-NUTS IN WOOD FIRST**

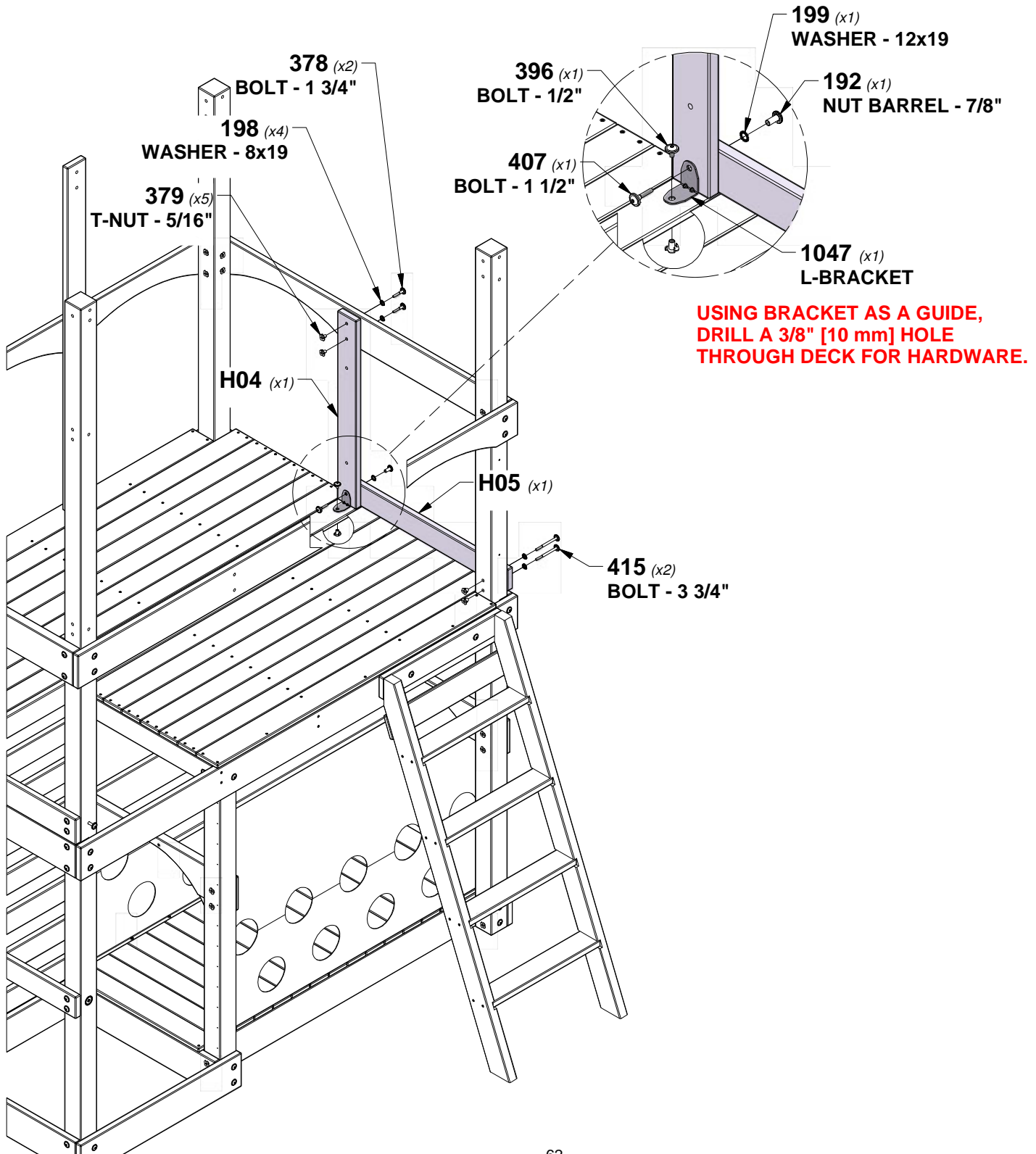

# STEP 30 - FORT ASSEMBLY

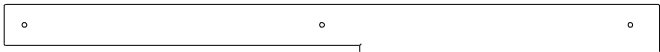

**AD02 WALL RAIL - W4L17743**  
(x1) 1"x4"x54 5/8" (24x102x1388)



**A4M01047 L BRACKET**  
(x1) 2.5x38x55x55

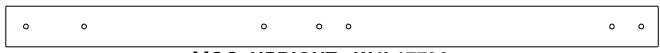

**H06 UPRIGHT - W4L17736**  
(x1) 1"x3 3/8"x54 3/8" (24x86x1382)

QTY	PART NUMBER	DESCRIPTION
1	H100192	NUT BARREL WH 5/16x7/8 BLK
3	H100198	WASHER LOCK EXT 8x19 BLK
1	H100199	WASHER LOCK EXT 12x19 BLK
2	H100378	BOLT WH 5/16x1 3/4 BLK
4	H100379	T-NUT 5/16 BLK
1	H100396	BOLT WH 5/16x1/2 BLK
1	H100407	BOLT WH 5/16x1 1/2 BLK
1	H100415	BOLT WH 5/16x3 3/4 BLK

**TIP:**  
**INSTALL T-NUTS IN WOOD FIRST**

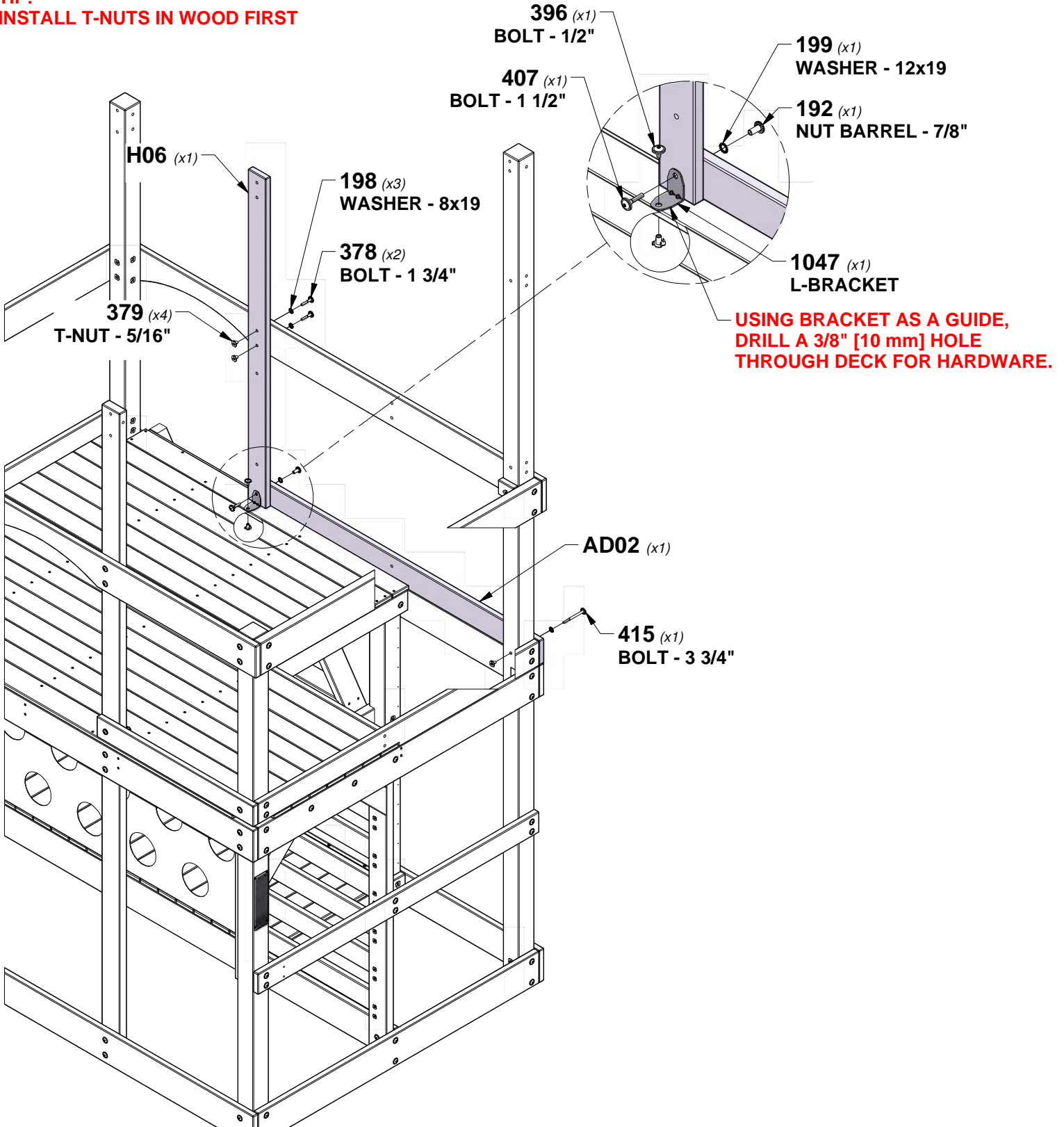

# STEP 31 - FORT ASSEMBLY



**E09 POST - W4L17739**  
(x1) 1 3/8"x3 3/8"x83 5/8" (36x86x2123)



**H10 FLOOR SUPPORT - W4L17758**  
(x1) 15/16"x3 3/8"x2 5/8" (24x86x66)

QTY	PART NUMBER	DESCRIPTION
3	H100198	WASHER LOCK EXT 8x19 BLK
2	H100205	BOLT WH 5/16x2-1/4 BLK
3	H100379	T-NUT 5/16 BLK
1	H100484	BOLT WH 5/16x3 1/4 BLK

**TIP:**  
**INSTALL T-NUTS IN WOOD FIRST**

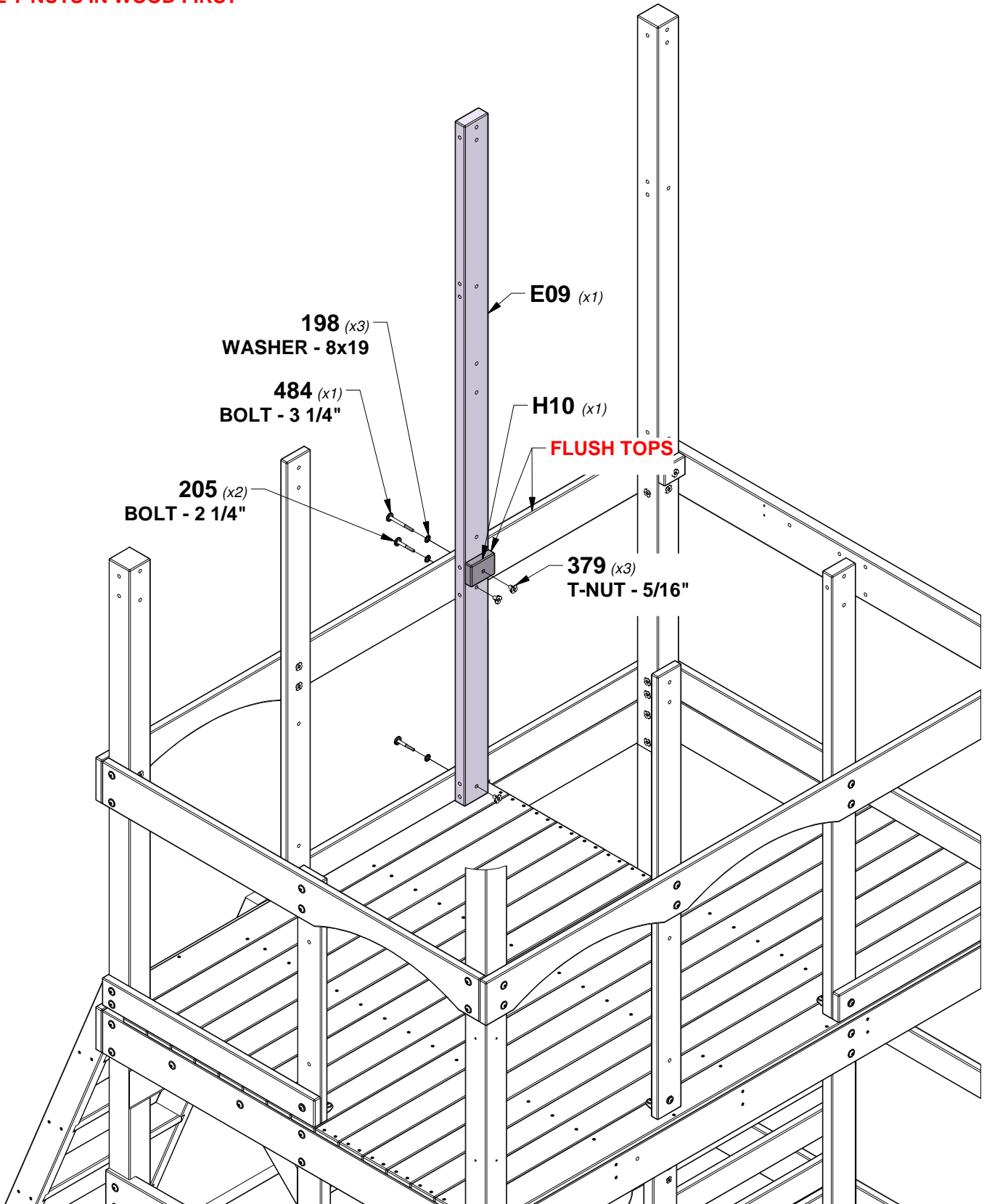

# STEP 32 - FORT ASSEMBLY



**E11 POST - W4L17753**  
(x1) 1 3/8"x3 3/8"x83 5/8" (36x86x2123)

**NOTE HOLE POSITIONS**



**A4M01047 L BRACKET**  
(x1) 2.5x38x55x55

QTY	PART NUMBER	DESCRIPTION
1	H100192	NUT BARREL WH 5/16x7/8 BLK
4	H100198	WASHER LOCK EXT 8x19 BLK
1	H100199	WASHER LOCK EXT 12x19 BLK
5	H100379	T-NUT 5/16 BLK
1	H100396	BOLT WH 5/16x1/2 BLK
1	H100468	BOLT WH 5/16x1 BLK
2	H100480	BOLT WH 5/16x4 3/4 BLK
2	H100513	BOLT WH 5/16x4 1/4 BLK

**TIP:**  
**INSTALL T-NUTS IN WOOD FIRST**

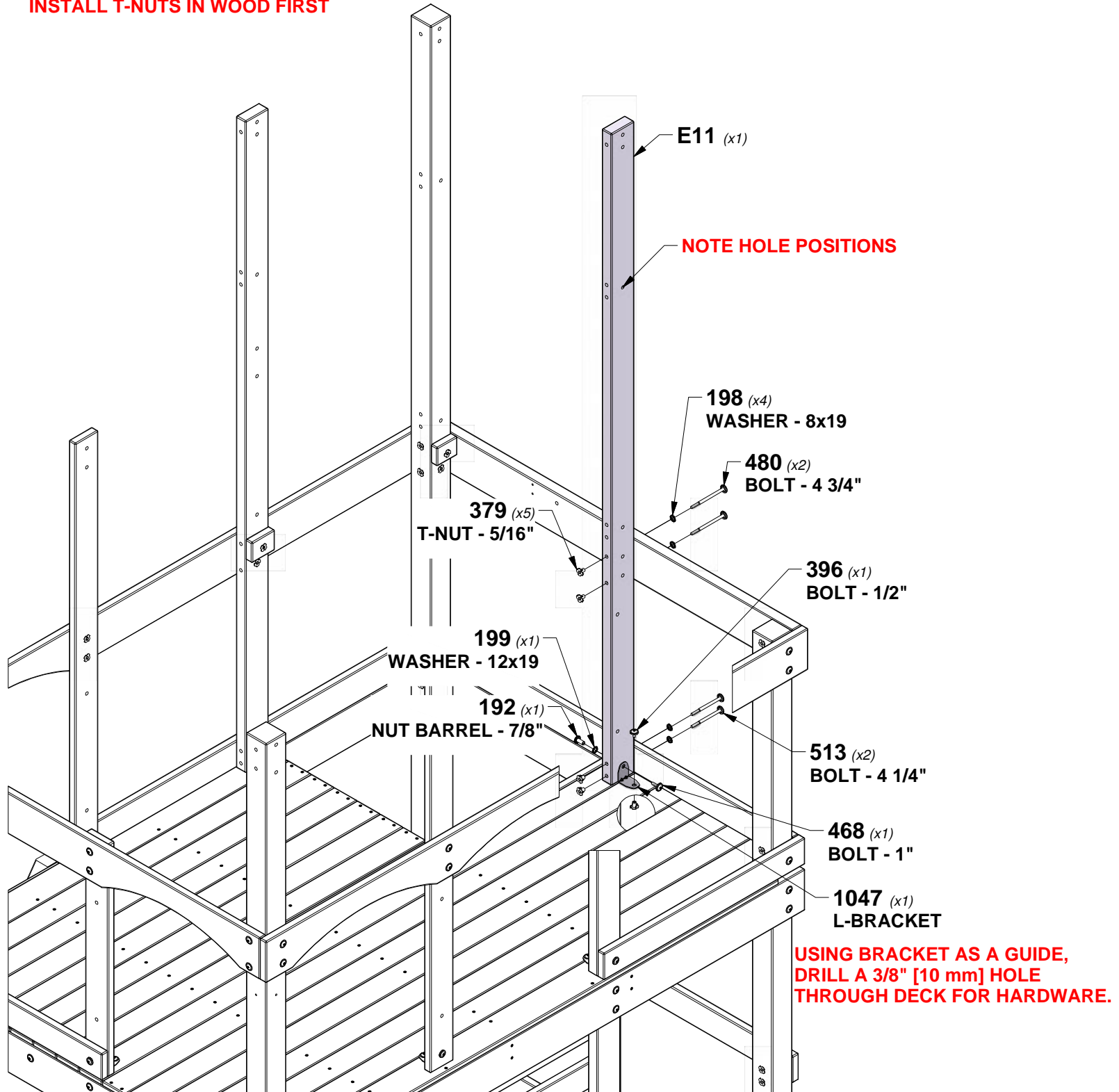

# STEP 33 - FORT ASSEMBLY



**E12 POST - W4L17768**  
(x1) 1 3/8"x3 3/8"x83 5/8" (36x86x2123)

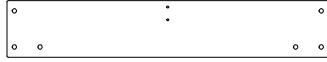

**G17 FLOOR RAIL - W4L17744**  
(x1) 1"x5 1/4"x30 1/4" (24x134x767)



**A4M01047 L BRACKET**  
(x1) 2.5x38x55x55

QTY	PART NUMBER	DESCRIPTION
1	H100192	NUT BARREL WH 5/16x7/8 BLK
4	H100198	WASHER LOCK EXT 8x19 BLK
1	H100199	WASHER LOCK EXT 12x19 BLK
5	H100379	T-NUT 5/16 BLK
1	H100396	BOLT WH 5/16x1/2 BLK
1	H100468	BOLT WH 5/16x1 BLK
4	H100513	BOLT WH 5/16x4 1/4 BLK

**TIP:**  
**INSTALL T-NUTS IN WOOD FIRST**

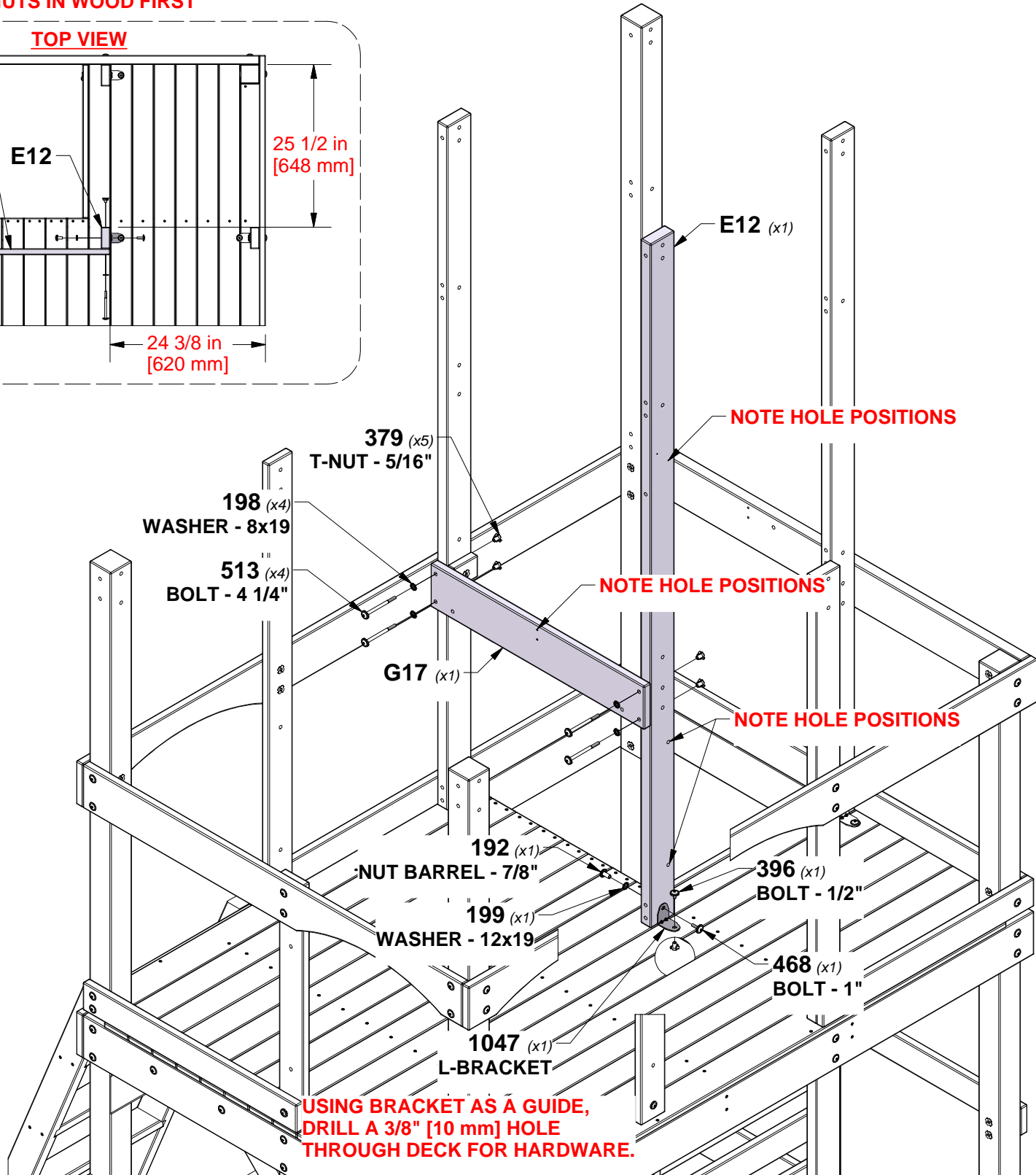
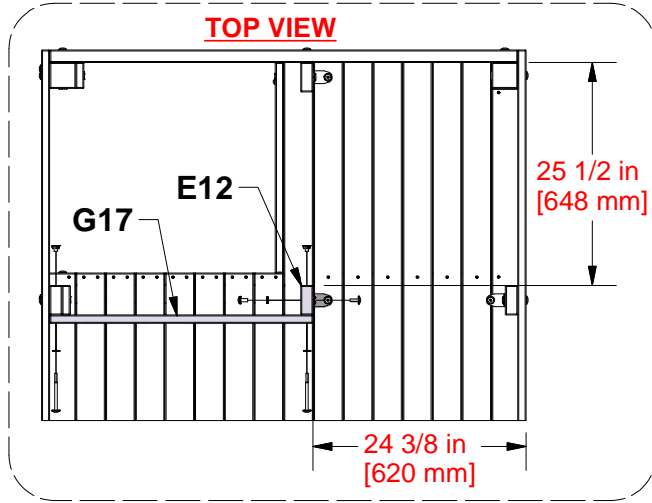



# STEP 34 - FORT ASSEMBLY



**G18 FLOOR SUPPORT - W4L17754**  
(x1) 1"x5 1/4"x29 7/8" (24x134x758)

1 3/8 in  
[36 mm]  
UP WHEN INSTALLED

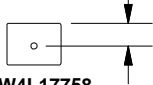

**H10 FLOOR SUPPORT - W4L17758**  
(x2) 15/16"x3 3/8"x2 5/8" (24x86x66)

QTY	PART NUMBER	DESCRIPTION
4	H100198	WASHER LOCK EXT 8x19 BLK
2	H100205	BOLT WH 5/16x2-1/4 BLK
4	H100379	T-NUT 5/16 BLK
2	H100484	BOLT WH 5/16x3 1/4 BLK

**TIP:**  
INSTALL T-NUTS IN WOOD FIRST

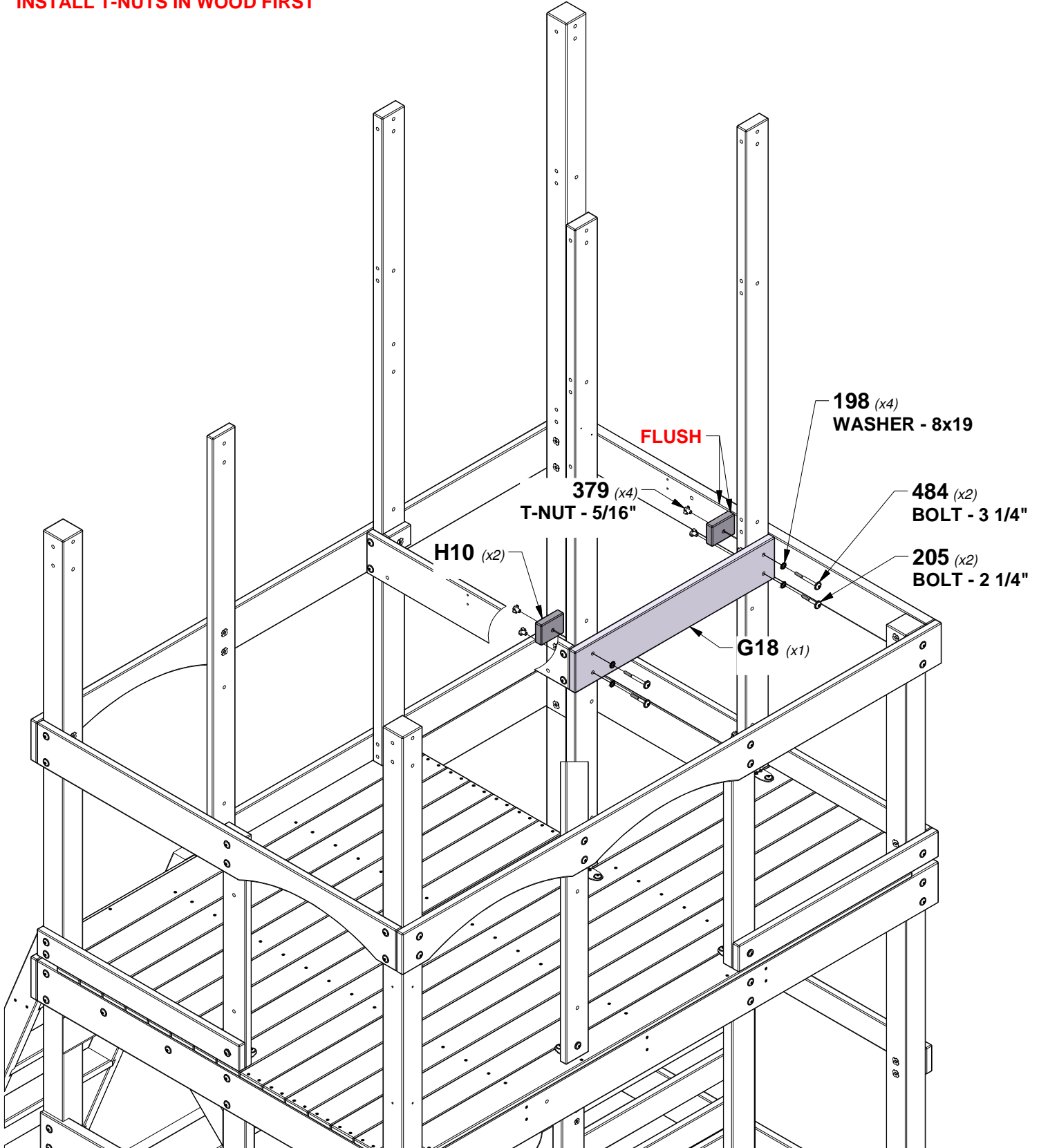

# STEP 35 - FORT ASSEMBLY



**H09 WALL RAIL - W4L17742**  
(x1) 1"x3 3/8"x30 1/4" (24x86x767)

QTY	PART NUMBER	DESCRIPTION
4	H100198	WASHER LOCK EXT 8x19 BLK
4	H100379	T-NUT 5/16 BLK
4	H100513	BOLT WH 5/16x4 1/4 BLK

**TIP:**  
INSTALL T-NUTS IN WOOD FIRST

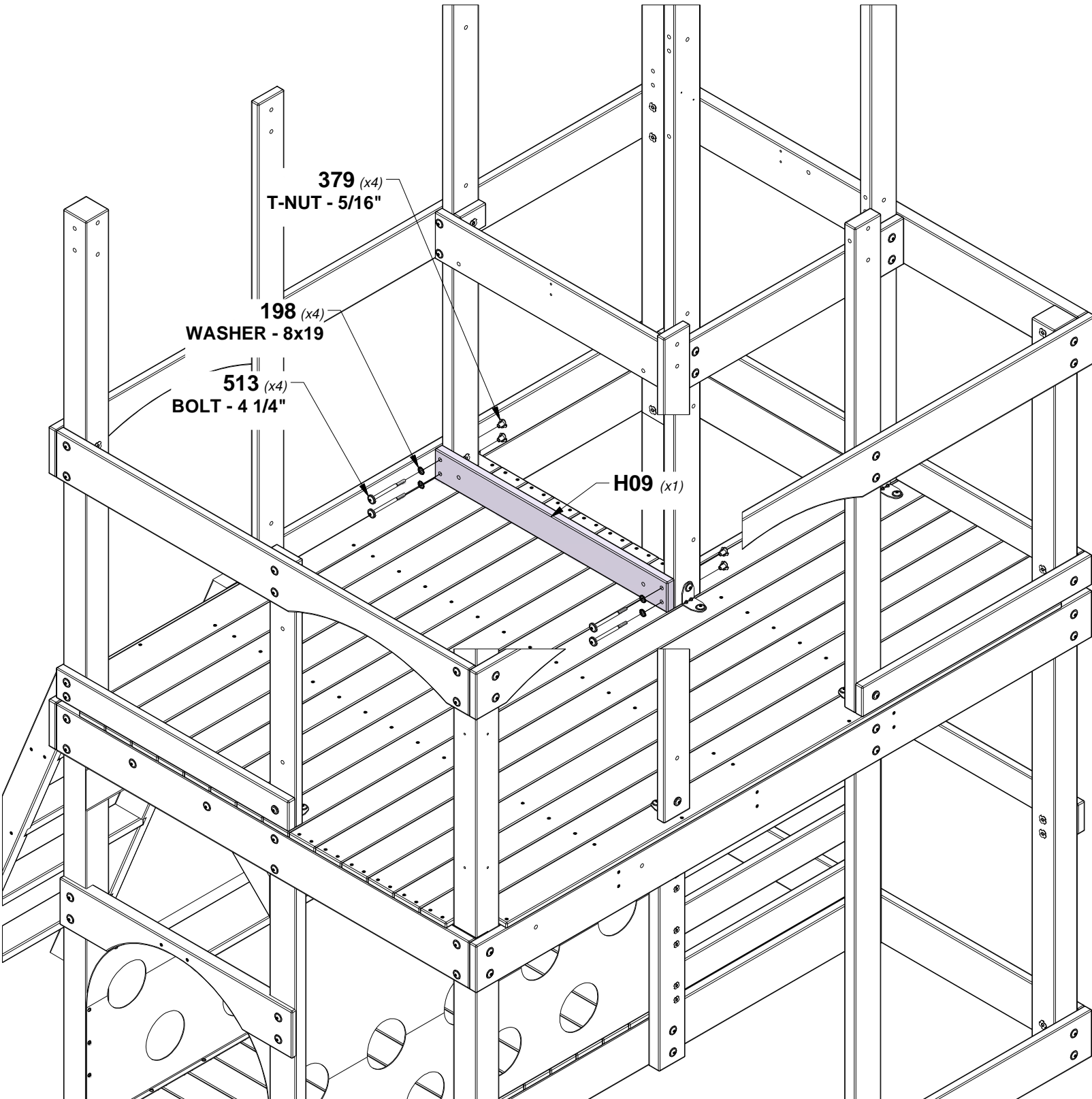



# STEP 36 - FORT ASSEMBLY

QTY	PART NUMBER	DESCRIPTION
4	H100201	SCREW PFH 8x2-1/2 BLK
2	H100379	T-NUT 5/16 BLK



**J02 FLOOR JOIST - W4L17746**  
(x1) 1"x2 3/8"x28 7/8" (24x60x734)

**TIP:**  
**INSTALL T-NUTS IN WOOD FIRST.**  
**FOR USE IN LATER STEP.**

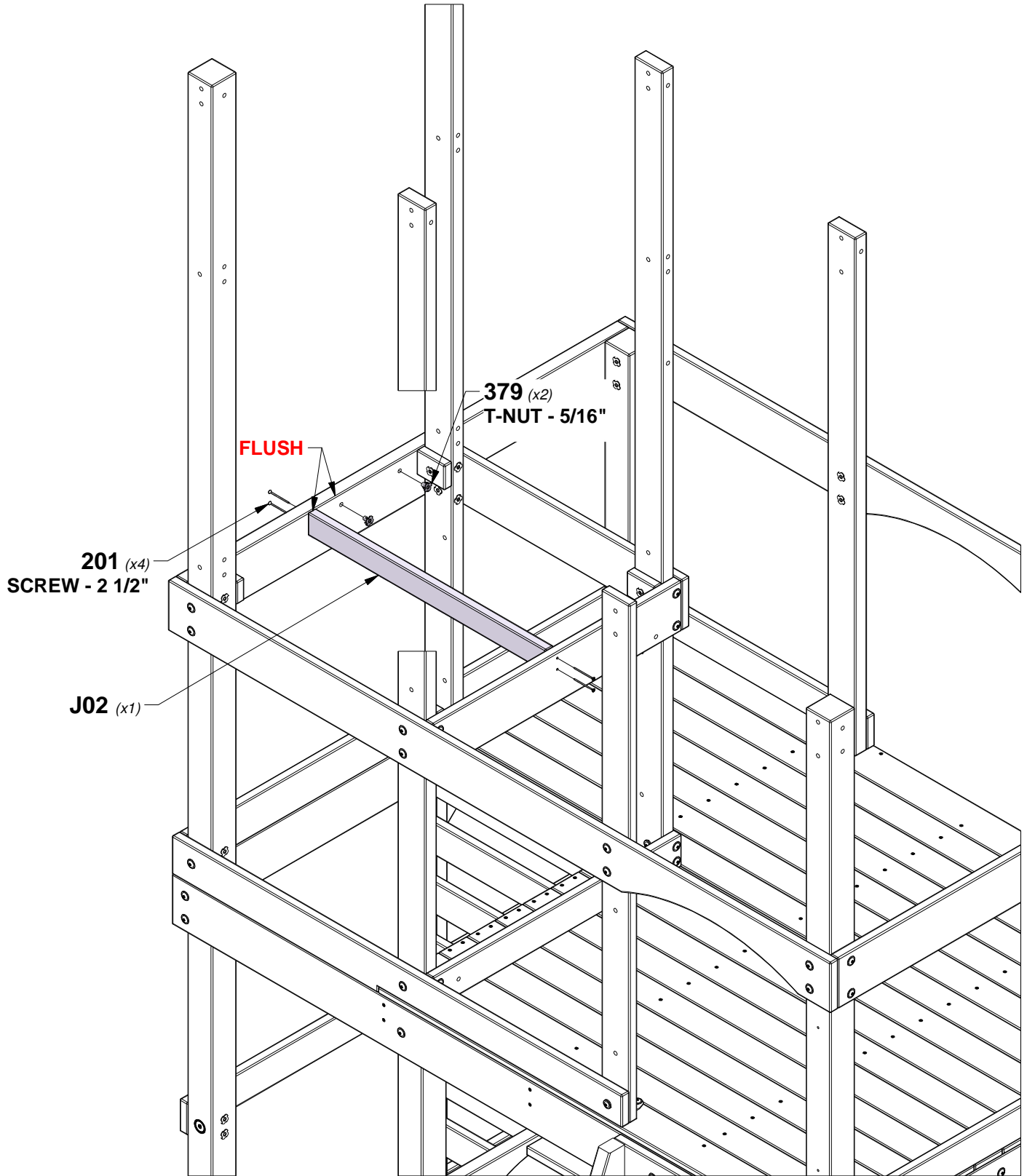

# STEP 37 - FORT ASSEMBLY

QTY	PART NUMBER	DESCRIPTION
44	H100086	SCREW PFH 8x1-1/2



**M22 FLOOR BOARD - W4L17762**  
(x4) 5/8"x3 3/8"x32 1/8" (16x86x815)



**L03 FLOOR BOARD - W4L17721**  
(x1) 5/8"x4 3/8"x32 1/8" (16x112x815)

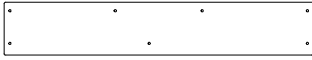

**L01 FLOOR BOARD - W4L17760**  
(x1) 5/8"x4 3/8"x25 3/4" (16x112x654)

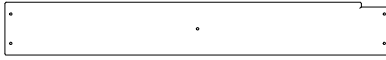

**L02 FLOOR BOARD - W4L17761**  
(x1) 5/8"x4 3/8"x32 1/8" (16x112x815)

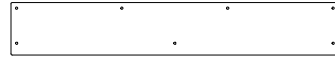

**Y03 FLOOR BOARD - W4L17759**  
(x1) 5/8"x4 3/8"x27 3/8" (16x111x694)

**NOTE:**  
ENSURE THAT PILOT HOLES ARE  
ALIGNED OVER FLOOR JOIST.

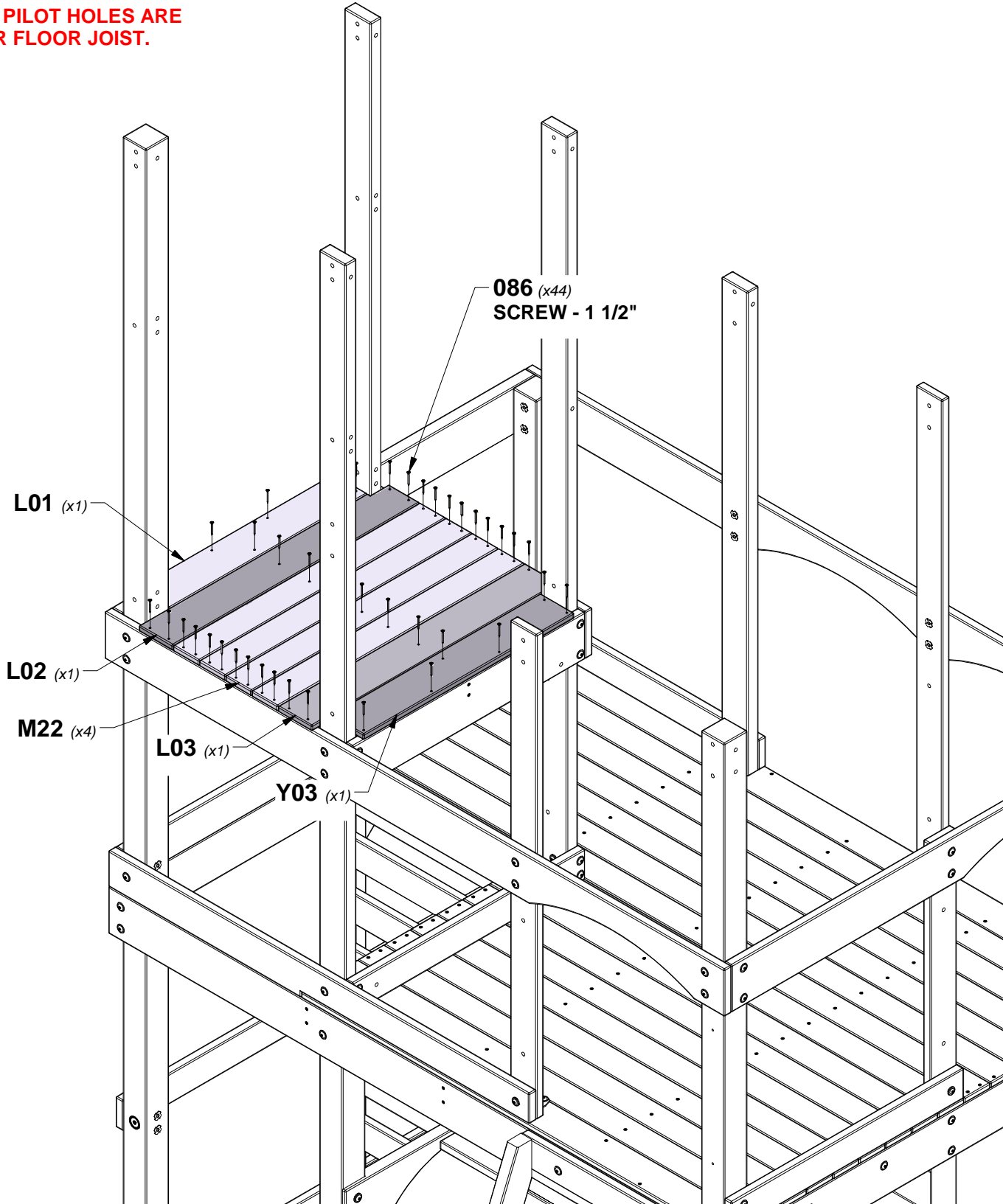

# STEP 38 - FORT ASSEMBLY

QTY	PART NUMBER	DESCRIPTION
8	H100198	WASHER LOCK EXT 8x19 BLK
3	H100205	BOLT WH 5/16x2-1/4 BLK
8	H100379	T-NUT 5/16 BLK
1	H100415	BOLT WH 5/16x3 3/4 BLK
2	H100480	BOLT WH 5/16x4 3/4 BLK
2	H100513	BOLT WH 5/16x4 1/4 BLK



**E10 WALL RAIL - W4L17757**  
(x1) 1 3/8"x3 3/8"x30 1/4" (36x86x767)



**H07 WALL RAIL - W4L17740**  
(x1) 1"x3 3/8"x30 3/8" (24x86x770) ← 1 3/4 in [43 mm]



**H08 WALL RAIL - W4L17741**  
(x1) 1"x3 3/8"x30 3/8" (24x86x770) ← 1 3/4 in [43 mm]

**TIP:**  
**INSTALL T-NUTS IN WOOD FIRST**

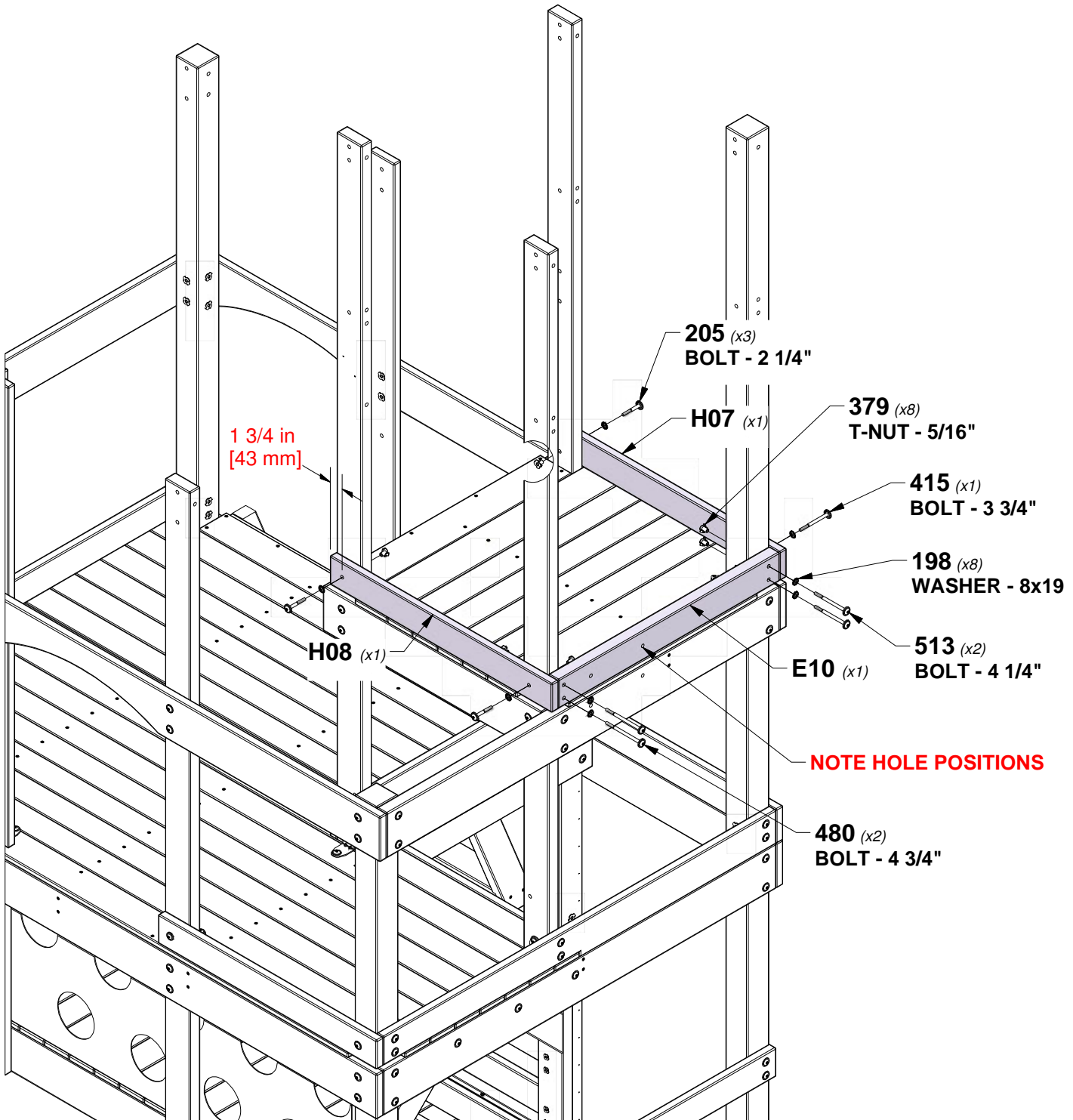

# STEP 39 - FORT ASSEMBLY

3/4 in  
[20 mm]

1 3/4 in  
[43 mm]

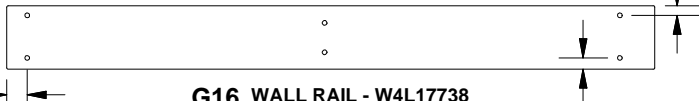

**G16 WALL RAIL - W4L17738**  
(x1) 1"x5 1/4"x54" (24x134x1372)

1 in  
[24 mm]

DOWNWARD WHEN INSTALLED

QTY	PART NUMBER	DESCRIPTION
4	H100198	WASHER LOCK EXT 8x19 BLK
1	H100205	BOLT WH 5/16x2-1/4 BLK
2	H100378	BOLT WH 5/16x1 3/4 BLK
4	H100379	T-NUT 5/16 BLK
1	H100415	BOLT WH 5/16x3 3/4 BLK

**TIP:**  
INSTALL T-NUTS IN WOOD FIRST

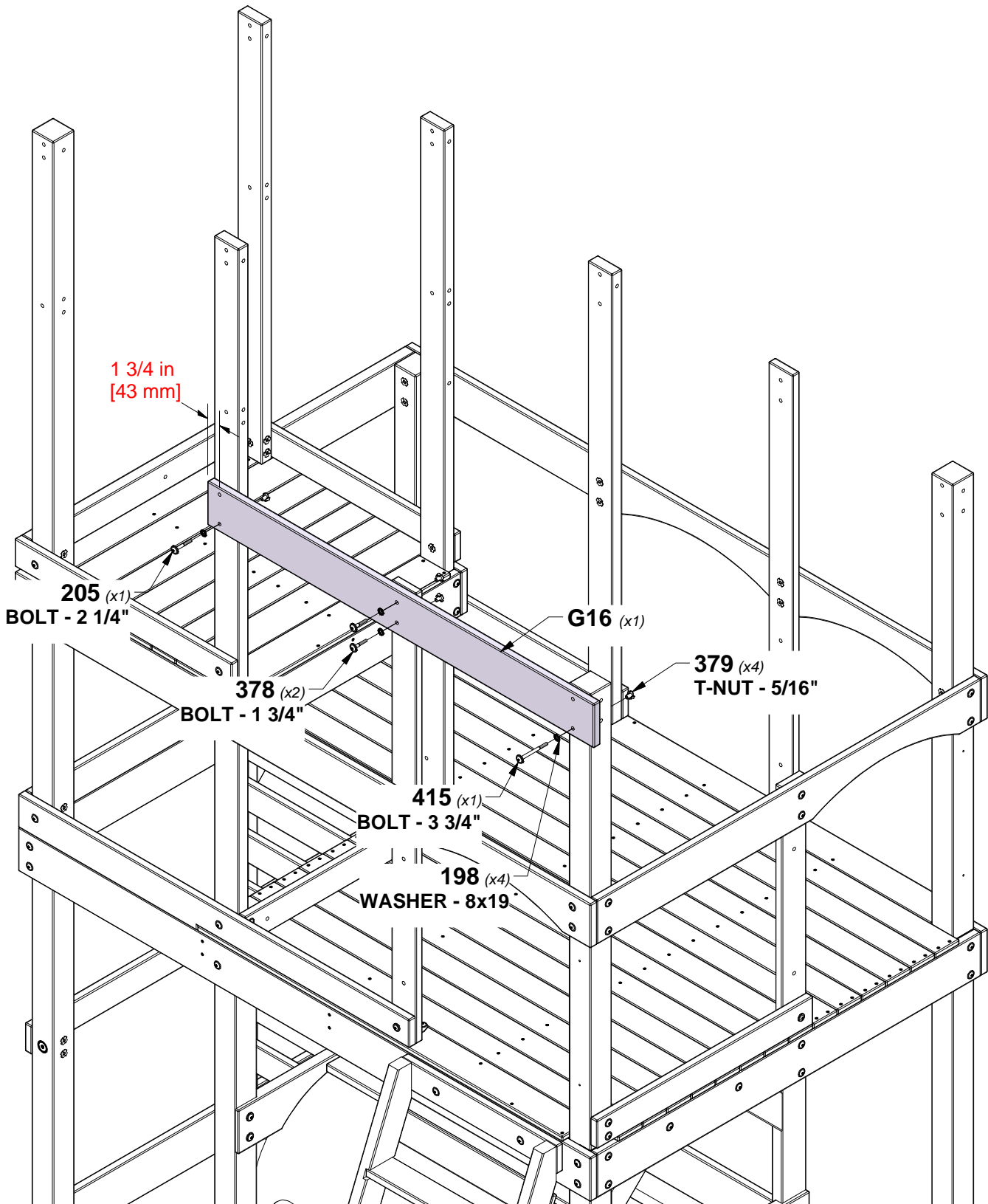

# STEP 40 - FORT ASSEMBLY

QTY	PART NUMBER	DESCRIPTION
4	H100198	WASHER LOCK EXT 8x19 BLK
4	H100379	T-NUT 5/16 BLK
4	H100513	BOLT WH 5/16x4 1/4 BLK



**D04 TOP RAIL - W4L17763**  
 (x1) 1 3/8"x5 1/4"x53 5/8" (36x134x1363)

**HOLES OFFSET DOWNWARD  
 WHEN INSTALLED**

**TIP:  
 INSTALL T-NUTS IN WOOD FIRST**

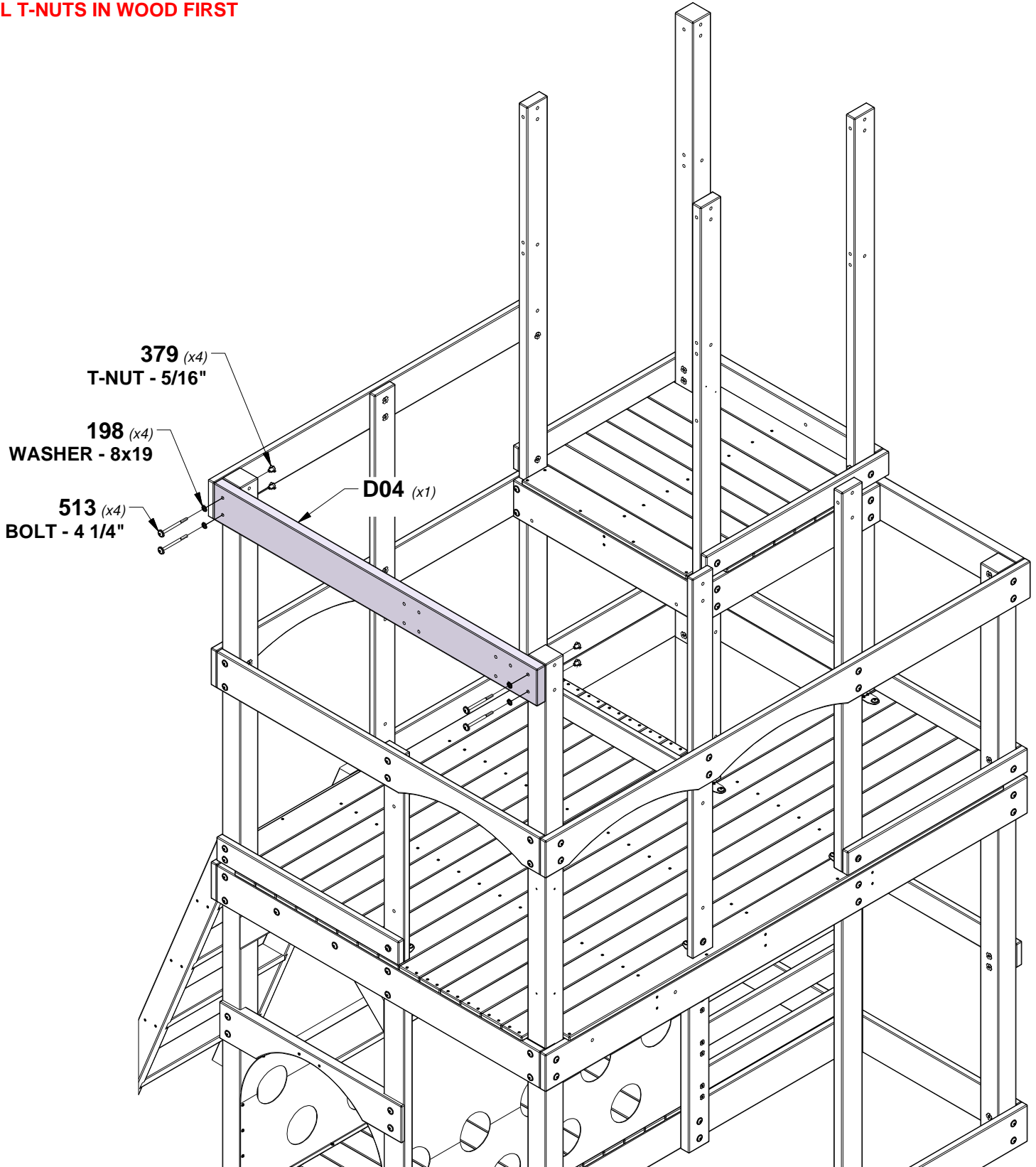

# STEP 41 - FORT ASSEMBLY

3/4 in [20 mm]

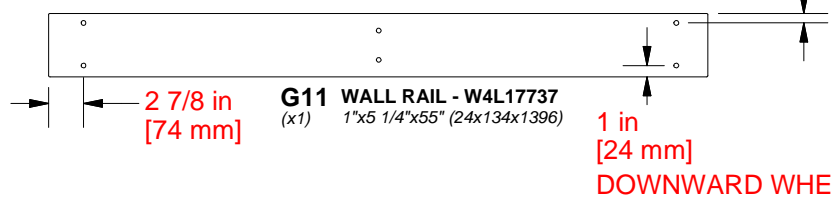

QTY	PART NUMBER	DESCRIPTION
4	H100198	WASHER LOCK EXT 8x19 BLK
1	H100205	BOLT WH 5/16x2-1/4 BLK
2	H100378	BOLT WH 5/16x1 3/4 BLK
4	H100379	T-NUT 5/16 BLK
1	H100415	BOLT WH 5/16x3 3/4 BLK

DOWNWARD WHEN INSTALLED

**TIP:**  
INSTALL T-NUTS IN WOOD FIRST

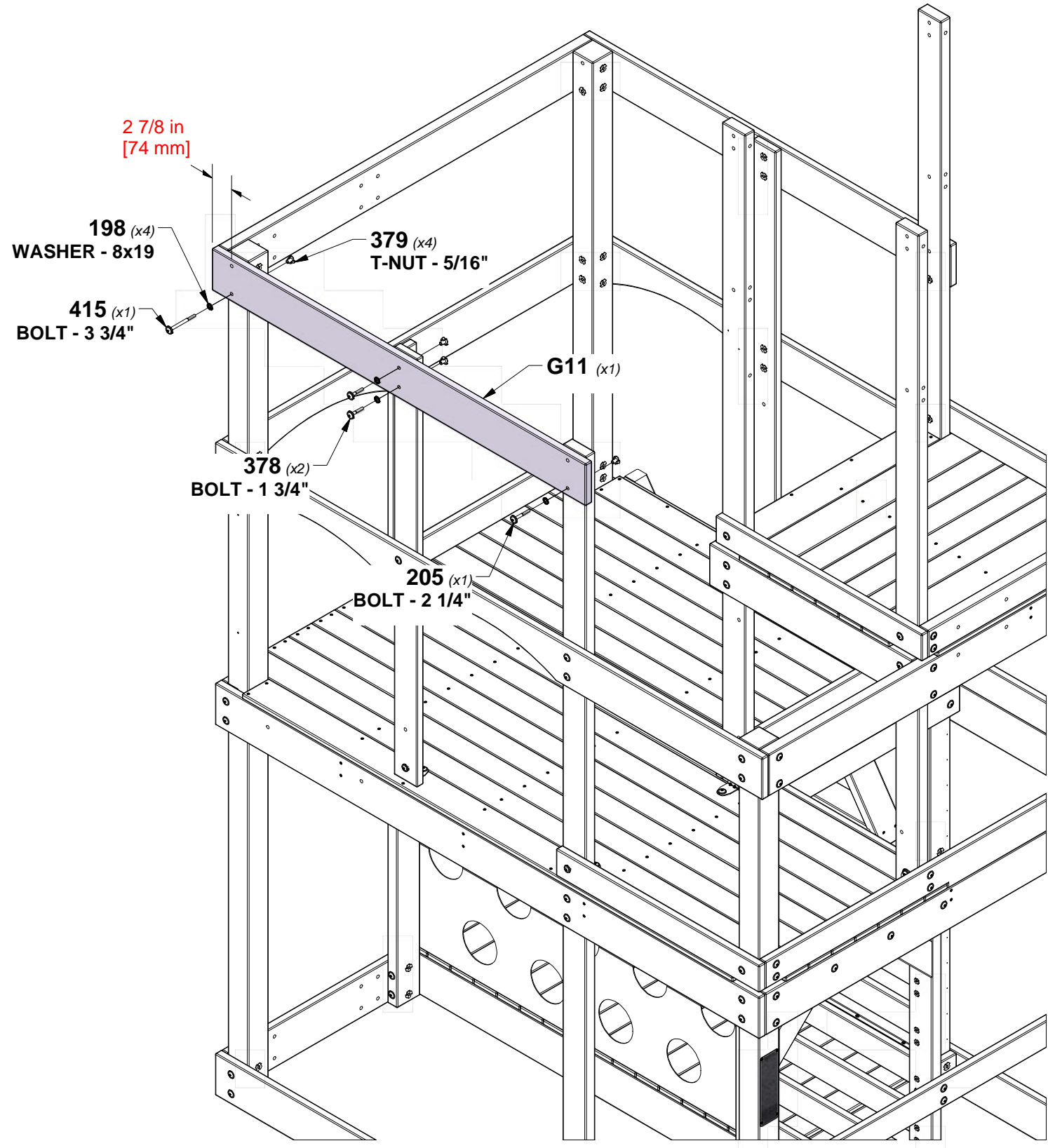



# STEP 42 - FORT ASSEMBLY

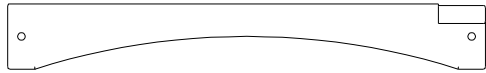

**H23 WALL RAIL - W4L17775**  
 (x1) 1"x3 3/8"x24 7/8" (24x86x632)

QTY	PART NUMBER	DESCRIPTION
2	H100198	WASHER LOCK EXT 8x19 BLK
2	H100379	T-NUT 5/16 BLK
2	H100513	BOLT WH 5/16x4 1/4 BLK

**TIP:**  
**INSTALL T-NUTS IN WOOD FIRST**

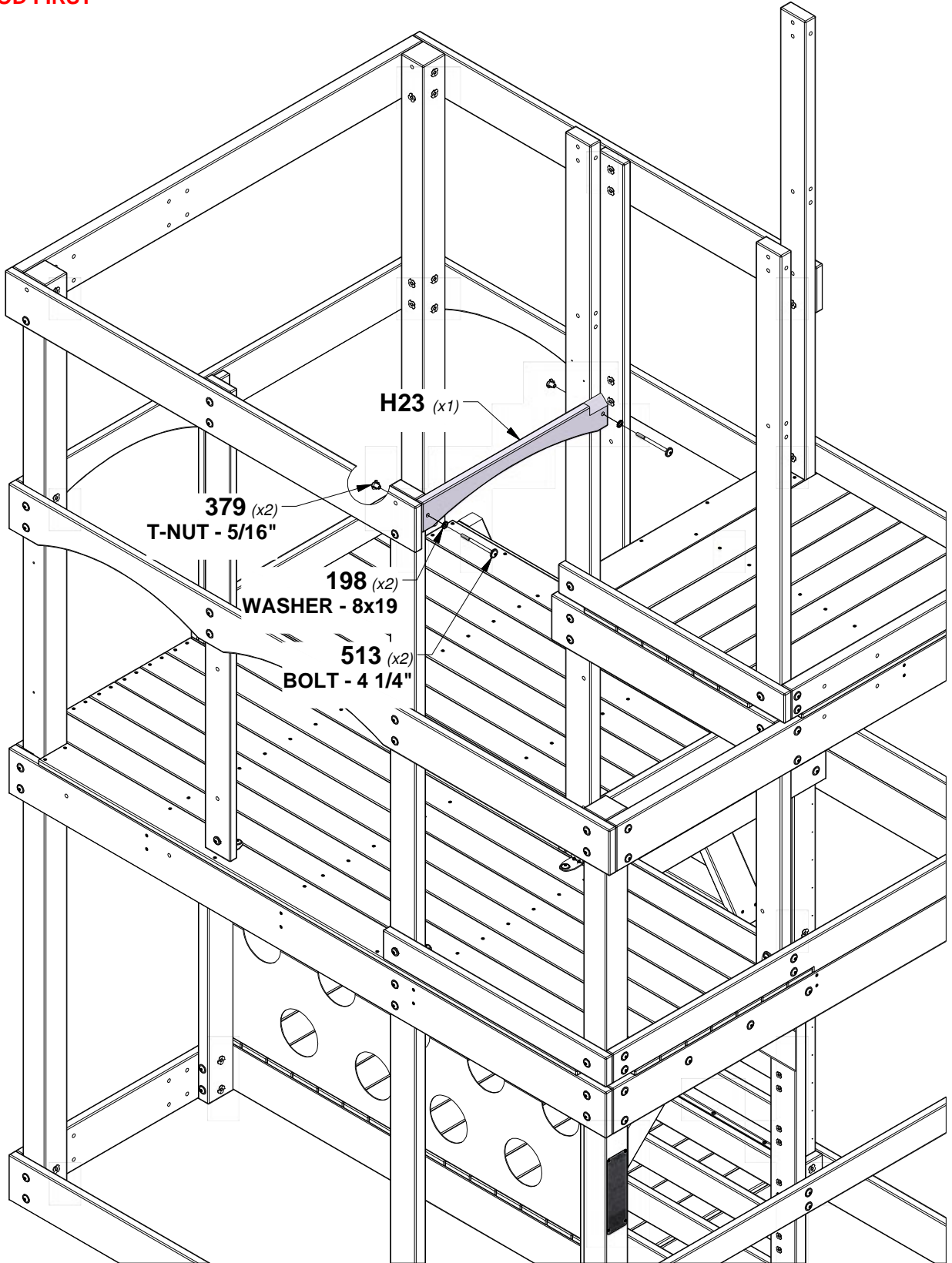

# STEP 43 - FORT ASSEMBLY

QTY	PART NUMBER	DESCRIPTION
6	H100198	WASHER LOCK EXT 8x19 BLK
6	H100379	T-NUT 5/16 BLK
2	H100415	BOLT WH 5/16x3 3/4 BLK
1	H100503	BOLT WH 5/16x3-1/2 BLK
1	H100512	BOLT WH 5/16x4 BLK
2	H100513	BOLT WH 5/16x4 1/4 BLK

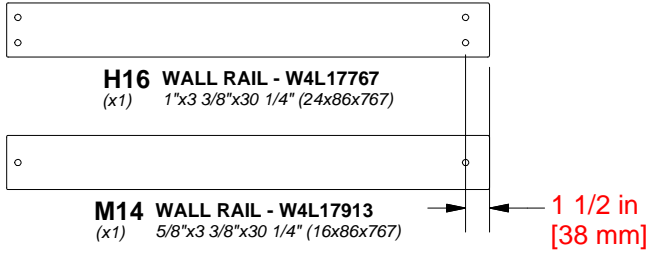

**TIP:**  
**INSTALL T-NUTS IN WOOD FIRST**

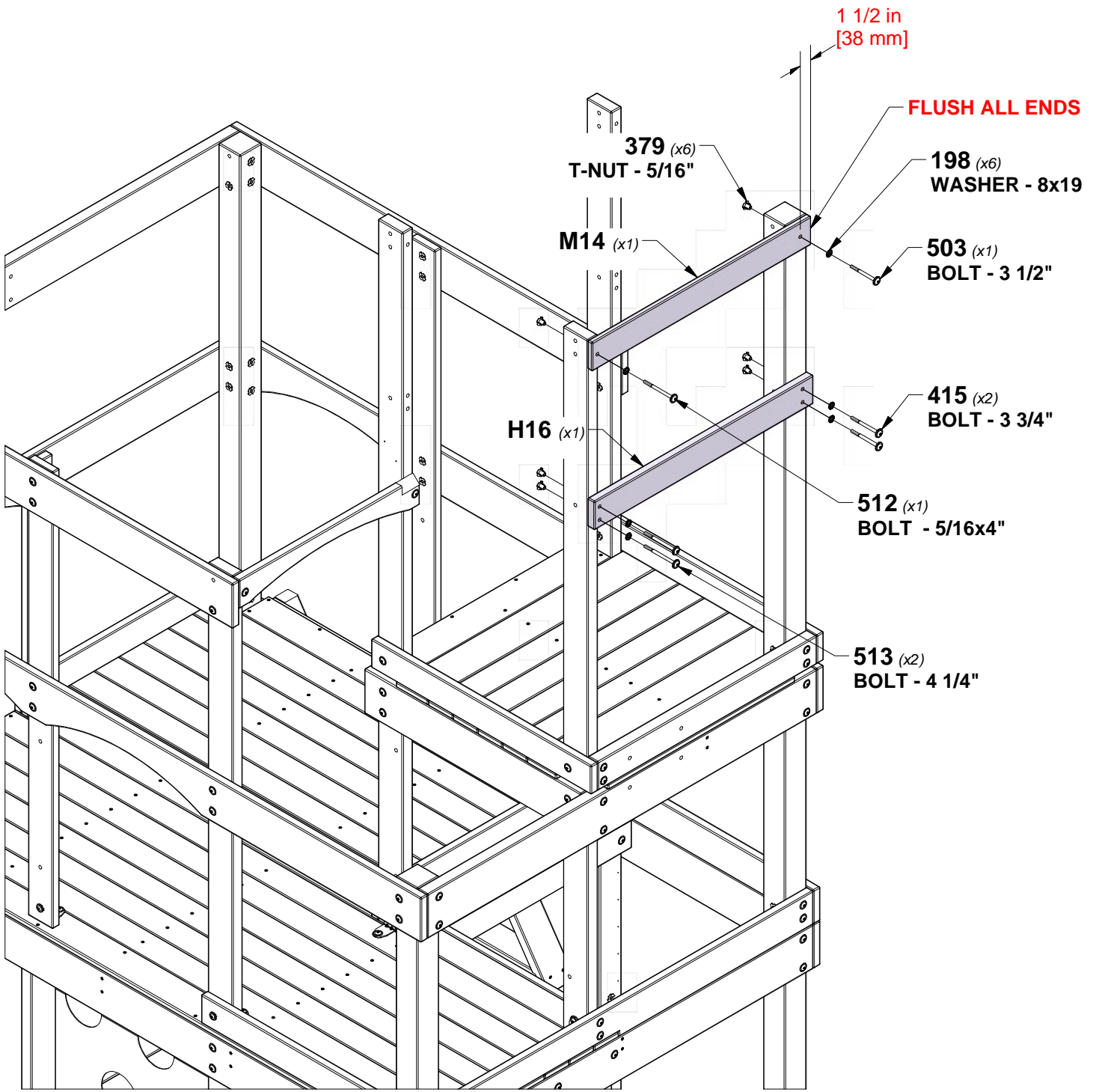



# STEP 44 - FORT ASSEMBLY

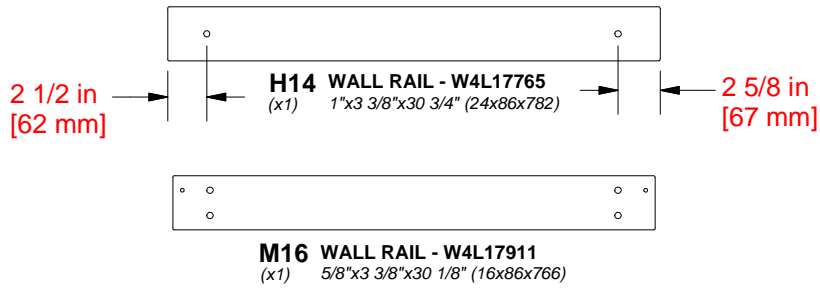

QTY	PART NUMBER	DESCRIPTION
6	H100198	WASHER LOCK EXT 8x19 BLK
1	H100205	BOLT WH 5/16x2-1/4 BLK
6	H100379	T-NUT 5/16 BLK
1	H100415	BOLT WH 5/16x3 3/4 BLK
2	H100457	BOLT WH 5/16x2 BLK
2	H100503	BOLT WH 5/16x3-1/2 BLK

**TIP:**  
INSTALL T-NUTS IN WOOD FIRST

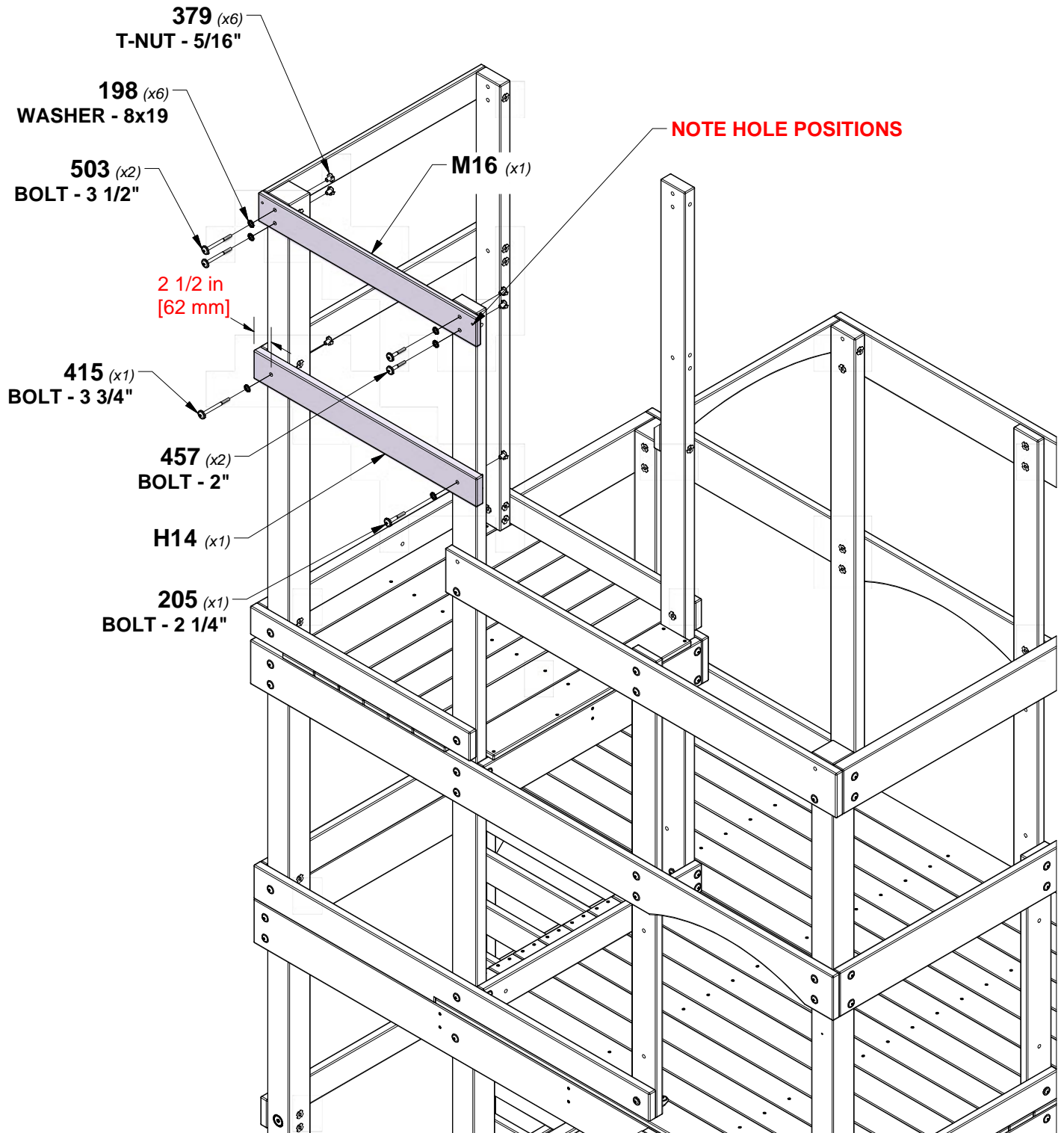

# STEP 45 - FORT ASSEMBLY



**H17 WALL RAIL - W4L17769**  
(x1) 1"x3 3/8"x30 1/4" (24x86x767)



**M15 WALL RAIL - W4L17914**  
(x1) 5/8"x3 3/8"x30 1/4" (16x86x767)

QTY	PART NUMBER	DESCRIPTION
6	H100198	WASHER LOCK EXT 8x19 BLK
6	H100379	T-NUT 5/16 BLK
2	H100512	BOLT WH 5/16x4 BLK
4	H100513	BOLT WH 5/16x4 1/4 BLK

**TIP:**  
**INSTALL T-NUTS IN WOOD FIRST**

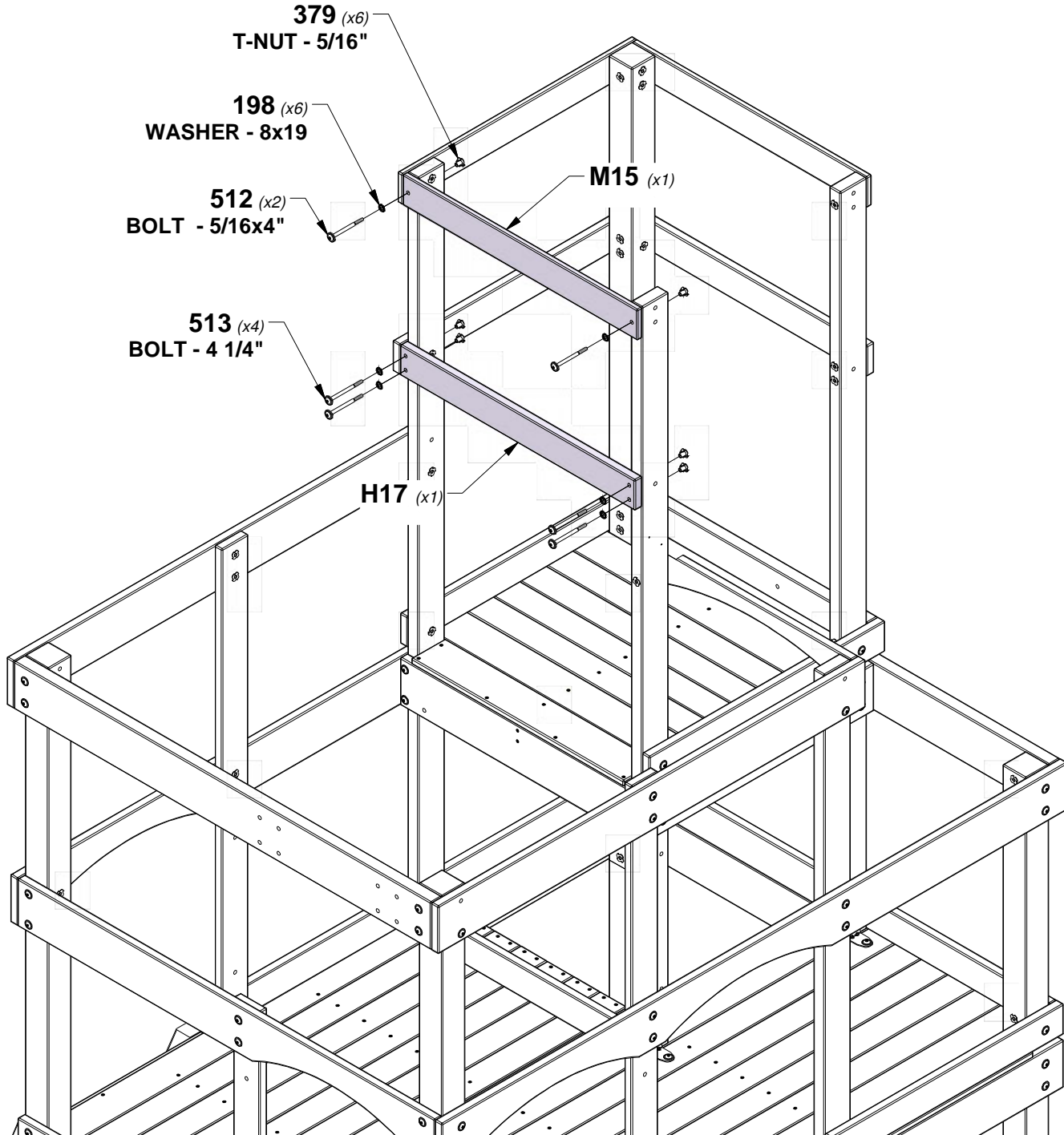

# STEP 46 - FORT ASSEMBLY

QTY	PART NUMBER	DESCRIPTION
6	H100198	WASHER LOCK EXT 8x19 BLK
2	H100205	BOLT WH 5/16x2 1/4 BLK
6	H100379	T-NUT 5/16 BLK
4	H100457	BOLT WH 5/16x2 BLK



**H15 WALL RAIL - W4L17766**  
(x1) 1"x3 3/8"x30 3/4" (24x86x782)



**M16 WALL RAIL - W4L17911**  
(x1) 5/8"x3 3/8"x30 1/8" (16x86x766)

**TIP:**  
**INSTALL T-NUTS IN WOOD FIRST**

**NOTE HOLE POSITIONS**

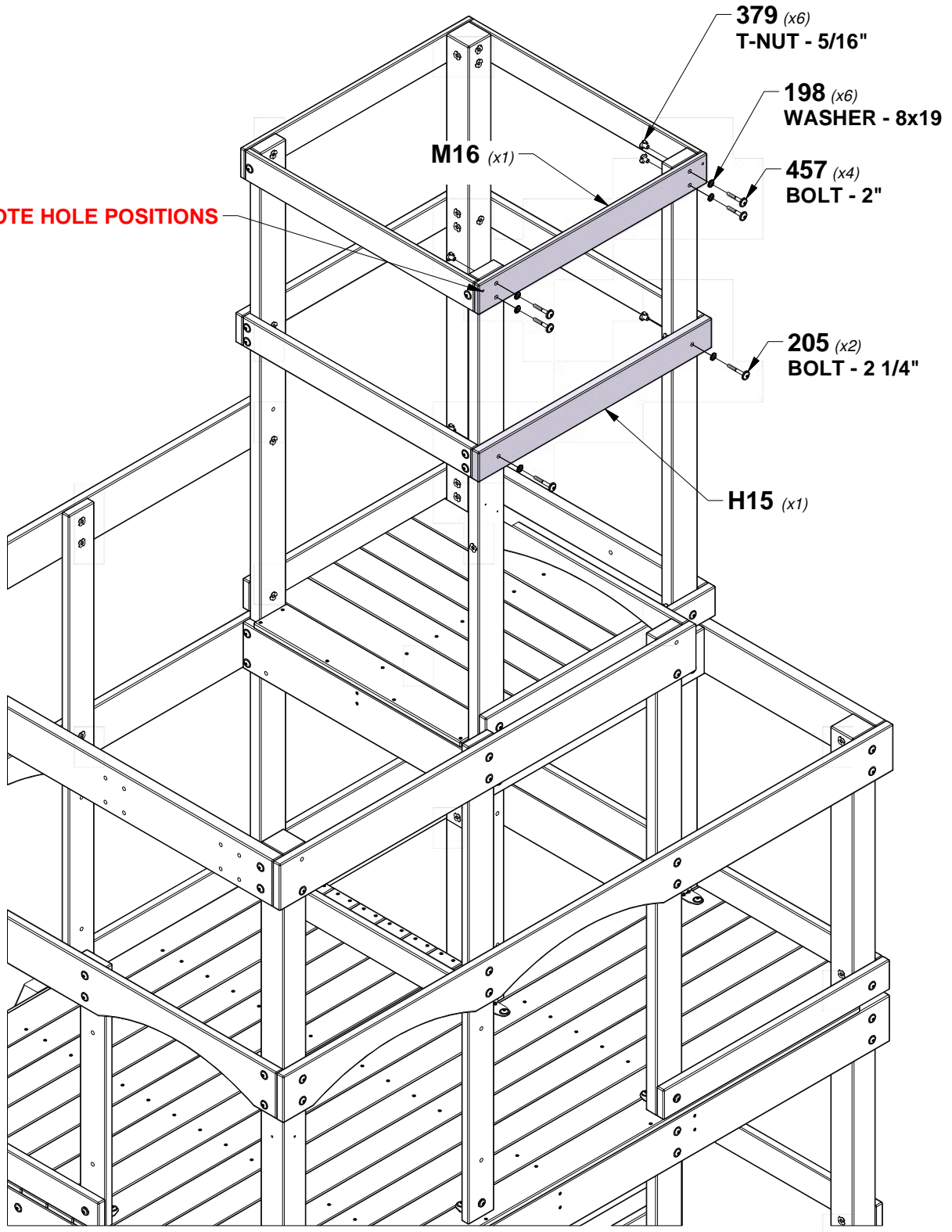

# STEP 47 - FORT ASSEMBLY

QTY	PART NUMBER	DESCRIPTION
4	H100198	WASHER LOCK EXT 8x19 BLK
4	H100378	BOLT WH 5/16x1 3/4 BLK
8	H100379	T-NUT 5/16 BLK
4	H100468	BOLT WH 5/16x1 BLK

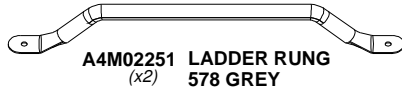

**HOLES OFFSET INWARD WHEN INSTALLED**

**TIP:**  
**INSTALL T-NUTS IN WOOD FIRST**

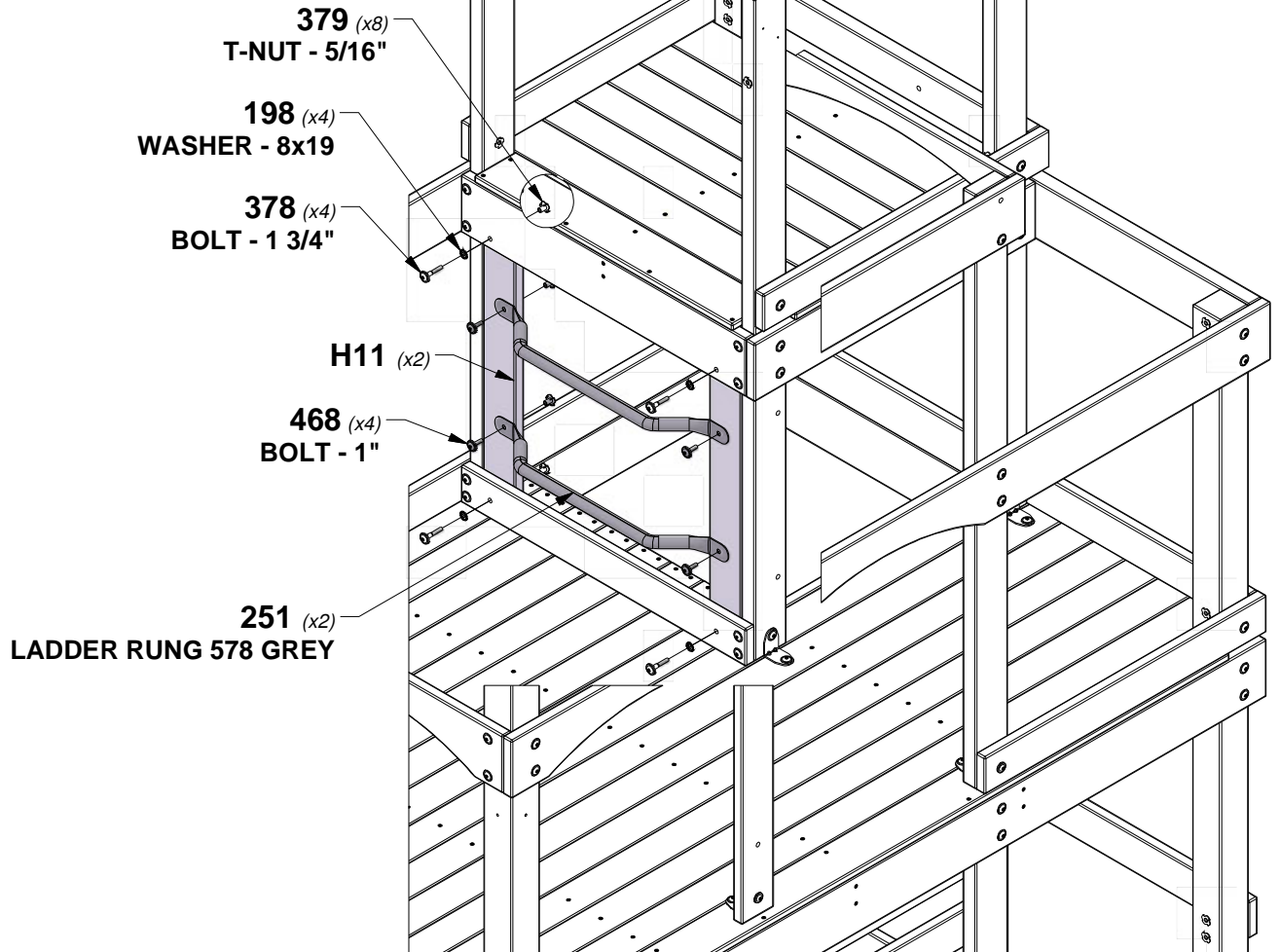
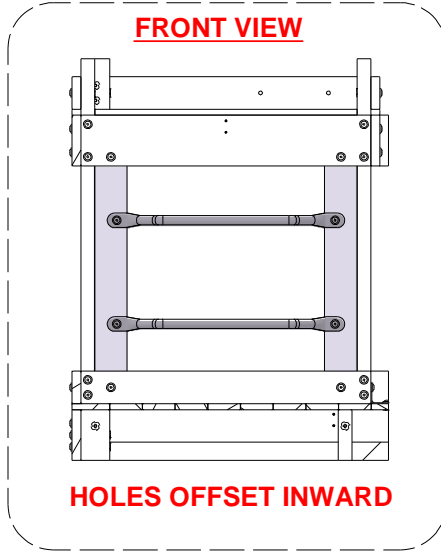

# STEP 48 - FORT ASSEMBLY

QTY	PART NUMBER	DESCRIPTION
12	H100087	SCREW PFH 8x1-1/4"



**M09 PICKET - W4L17752**  
(x3) 5/8"x3 3/8"x26 5/8" (16x86x675)

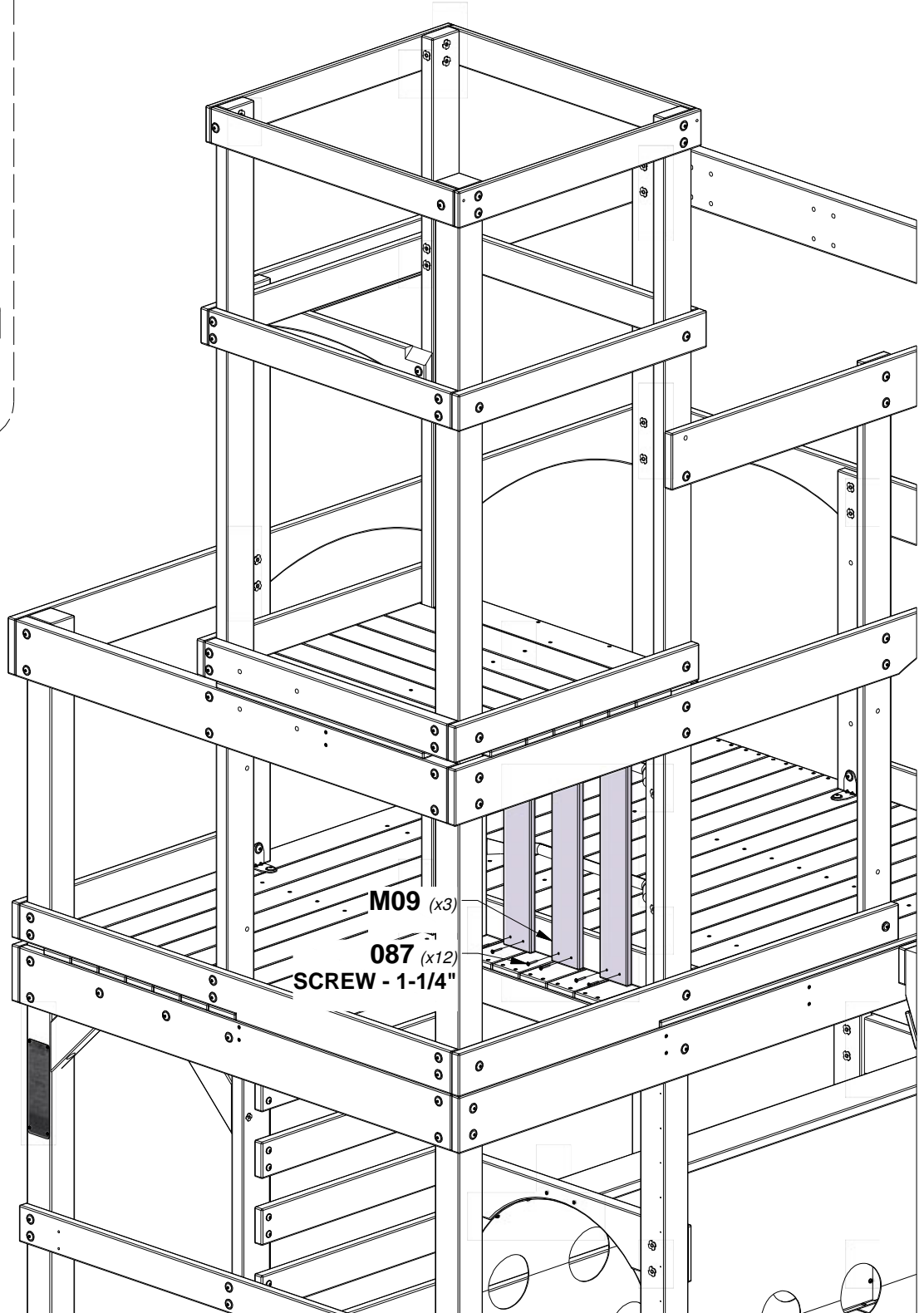
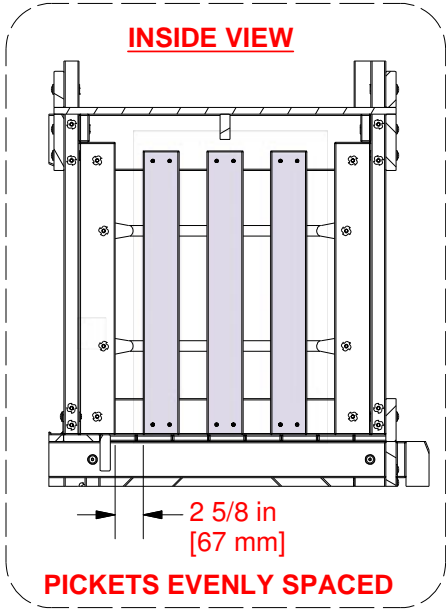

# STEP 49 - FORT ASSEMBLY

QTY	PART NUMBER	DESCRIPTION
4	H100379	T-NUT 5/16 BLK
4	H100407	BOLT WH 5/16x1 1/2 BLK

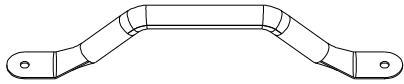

A4M02249 **HAND GRIP**  
(x2) METAL GREY 381  
c/c

**TIP:**  
**INSTALL T-NUTS IN WOOD FIRST**

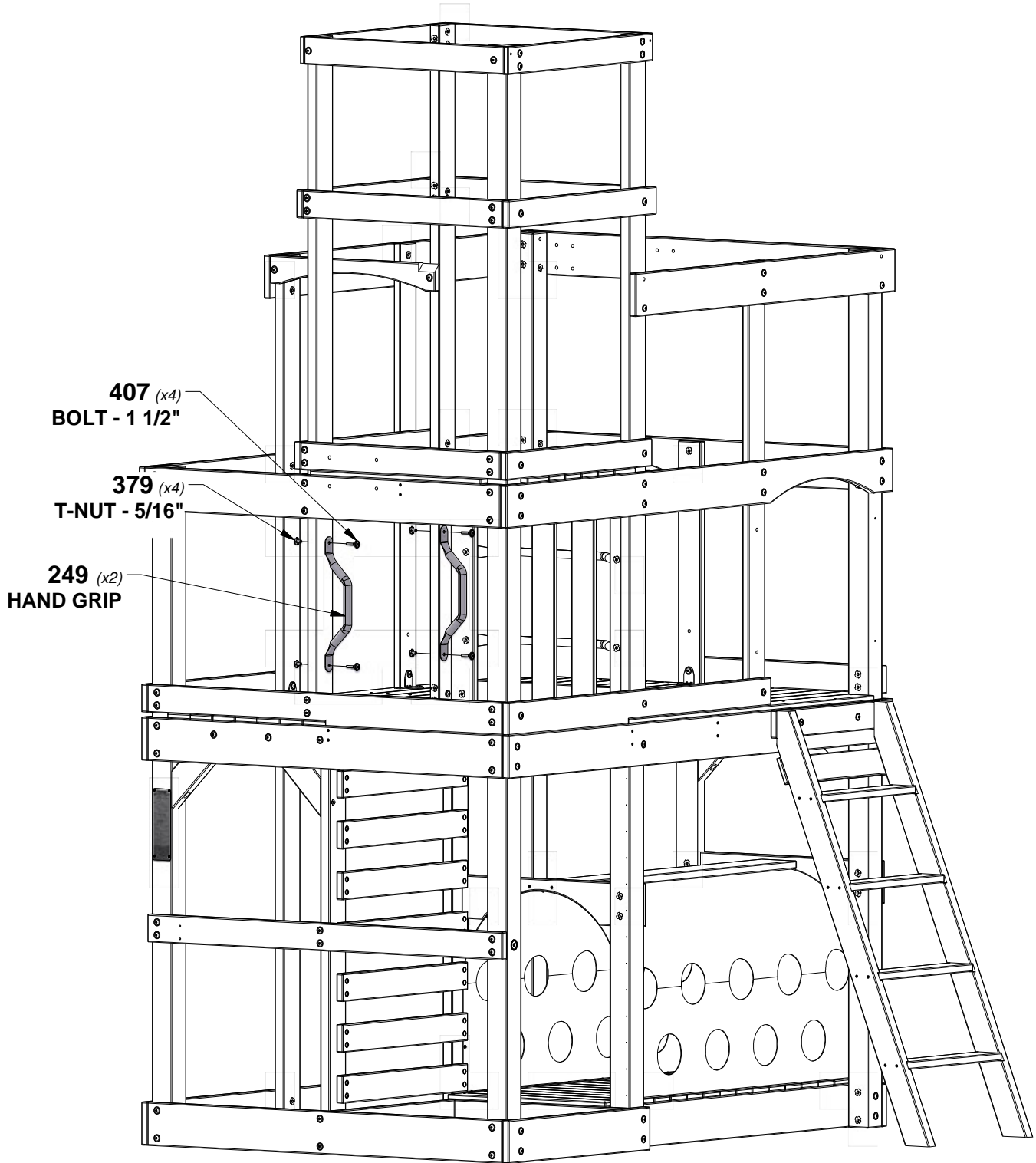



# STEP 50 - FORT ASSEMBLY

QTY	PART NUMBER	DESCRIPTION
16	H100087	SCREW PFH 8x1-1/4"



**M09 PICKET - W4L17752**  
(x4) 5/8"x3 3/8"x26 5/8" (16x86x675)

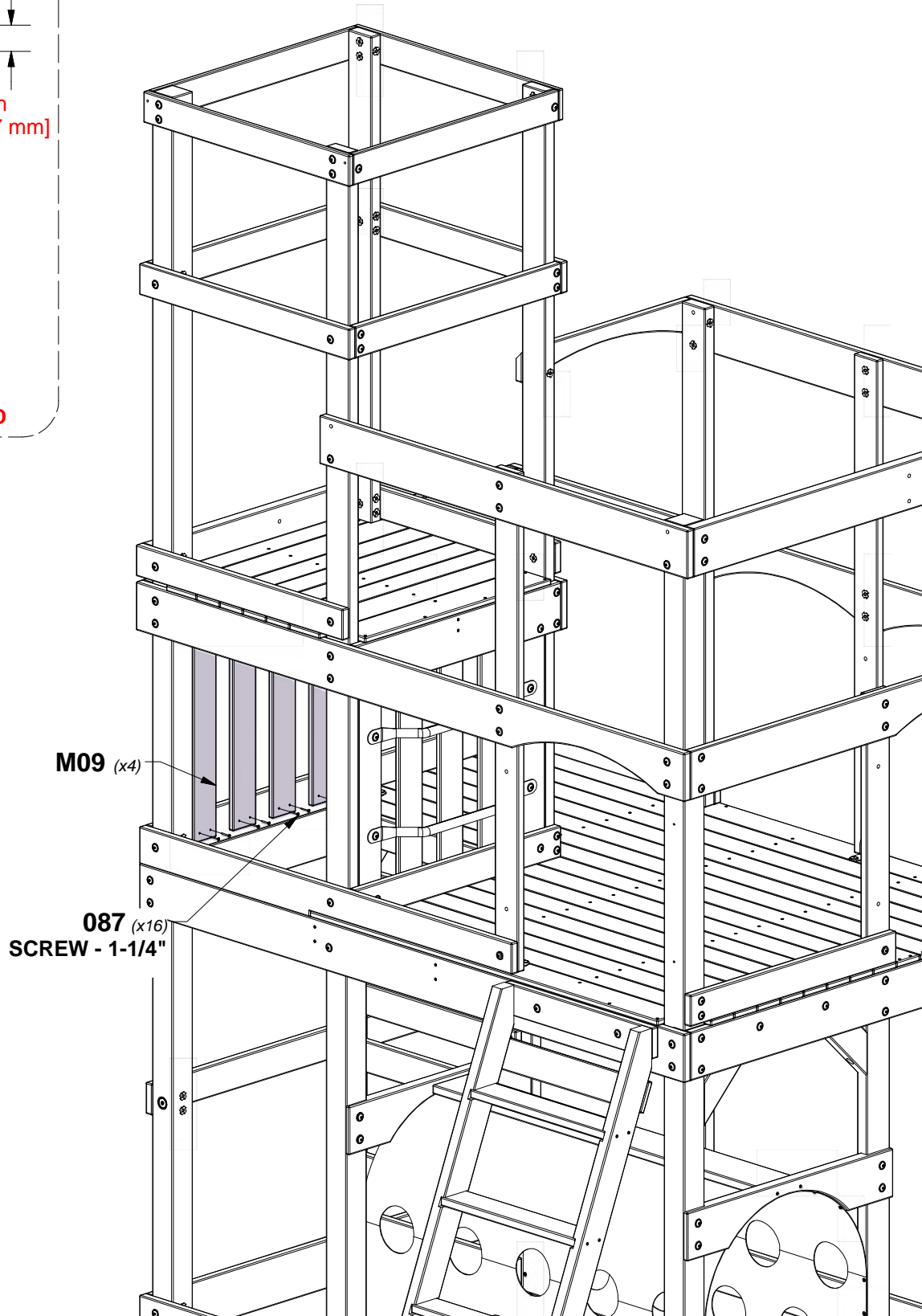
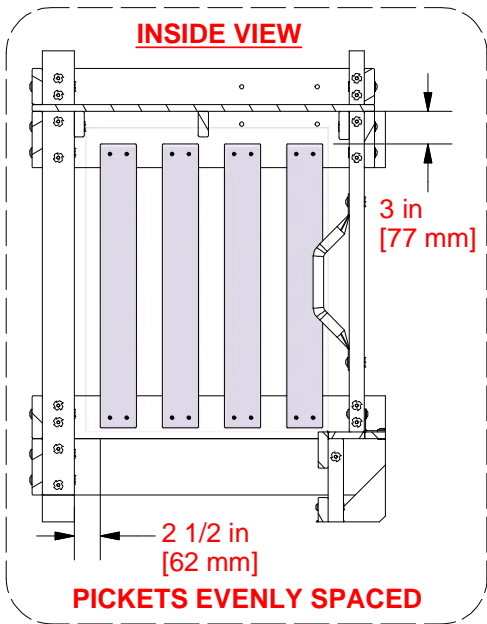

# STEP 51 - FORT ASSEMBLY

QTY	PART NUMBER	DESCRIPTION
12	H100087	SCREW PFH 8x1-1/4"



**M09 PICKET - W4L17752**  
(x3) 5/8"x3 3/8"x26 5/8" (16x86x675)

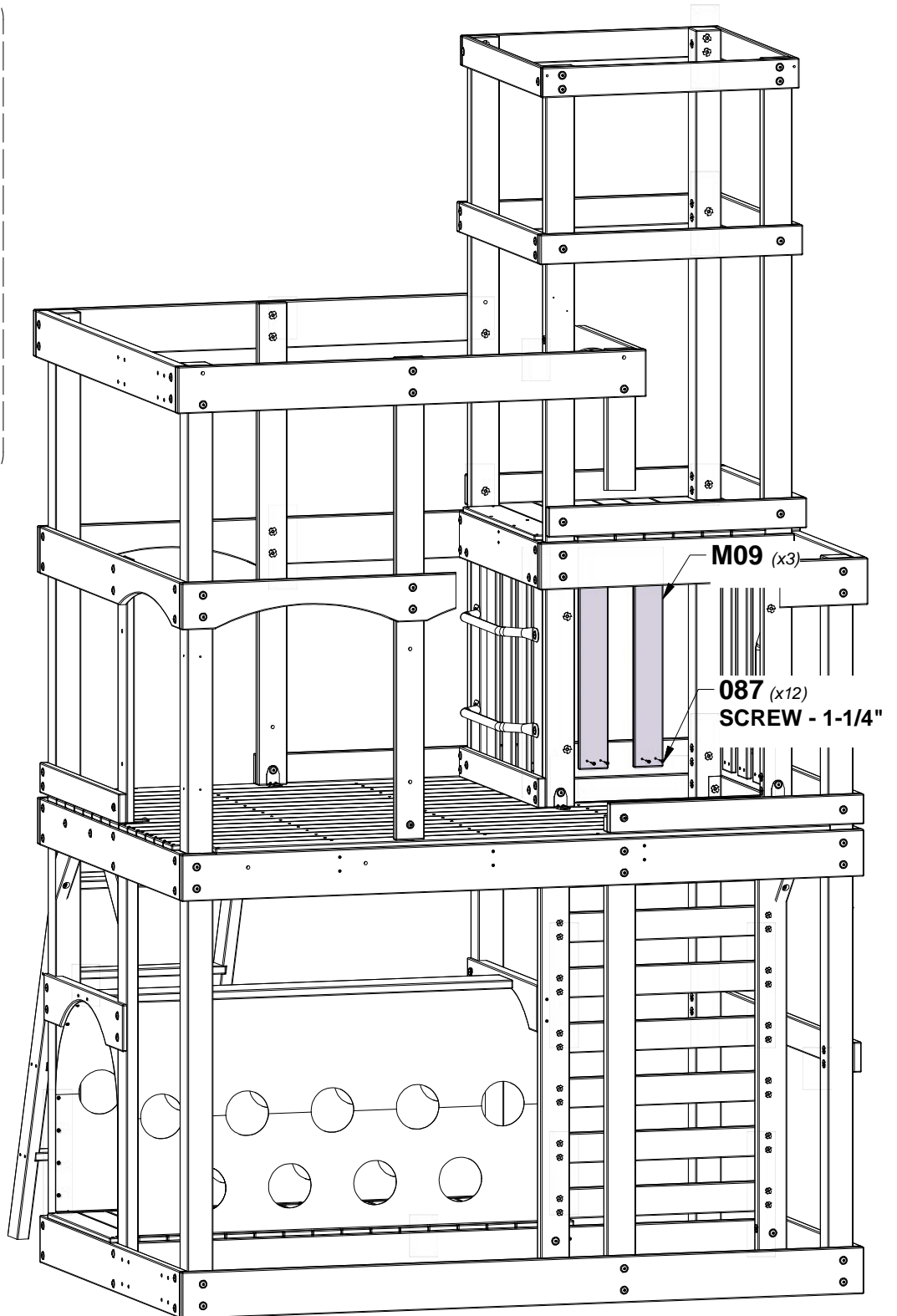
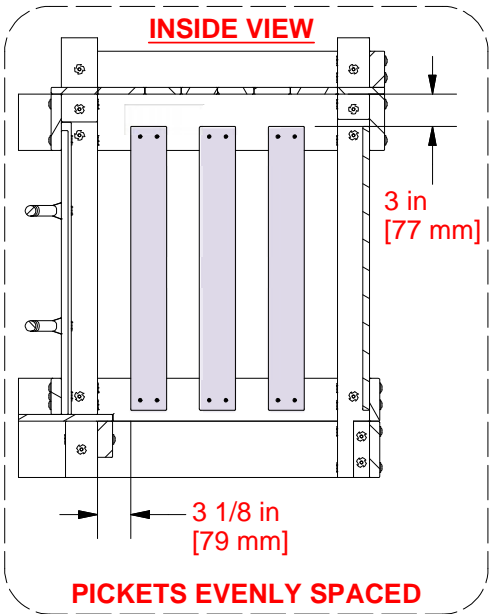



# STEP 52 - FORT ASSEMBLY

QTY	PART NUMBER	DESCRIPTION
36	H100087	SCREW PFH 8x1-1/4"
4	H100128	SCREW PWH 8x5/8



**M04 WALL BOARD - W4L17747**  
(x3) 5/8"x3 3/8"x46 1/2" (16x86x1182)



**M05 WALL BOARD - W4L17748**  
(x1) 5/8"x3 3/8"x46 1/2" (16x86x1182)



**M06 WALL BOARD - W4L17749**  
(x2) 5/8"x3 3/8"x46 1/2" (16x86x1182)



**A6P00052 OVAL WINDOW**  
(x1)

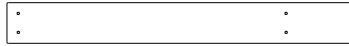

**M07 WALL BOARD - W4L17750**  
(x1) 5/8"x3 3/8"x29 1/4" (16x86x742)

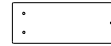

**M08 WALL BOARD - W4L17751**  
(x1) 5/8"x3 3/8"x8 5/8" (16x86x219)

## INSIDE VIEW

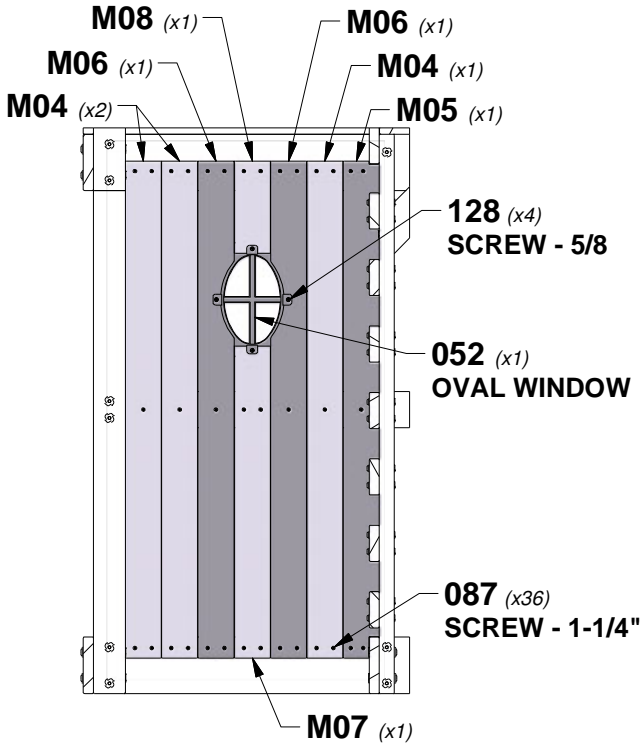

## PART PLACEMENT

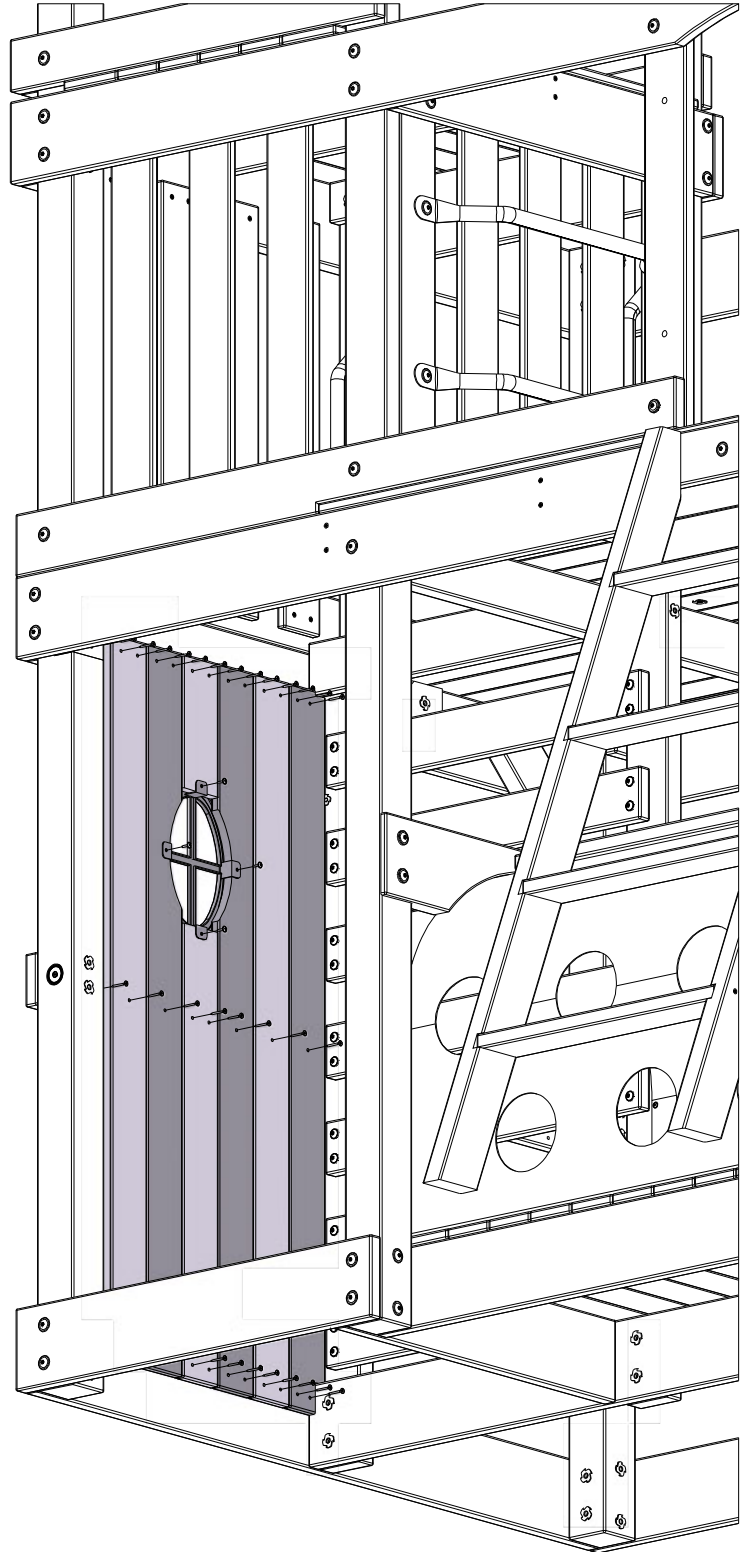

# STEP 53 - FORT ASSEMBLY

QTY	PART NUMBER	DESCRIPTION
10	H100087	SCREW PFH 8x1-1/4"
4	H100089	SCREW PFH 8x1-3/4"
1	H100171	BOLT WH 1/4x1 BLK
1	H100398	T-NUT 1/4 BLK
1	H100405	WASHER LOCK EXT 6x15 BLK

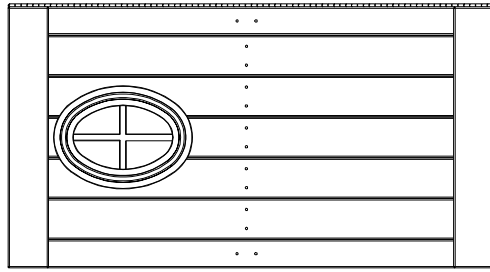

(x1) DOOR SUB-ASSEMBLY

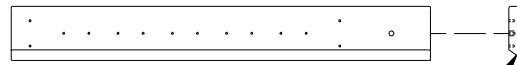

**H03 DOOR RAIL - W4L17764**  
(x1) 1"x3 3/8"x26 1/4" (24x86x666)

**BEVEL DOWN WHEN INSTALLED**

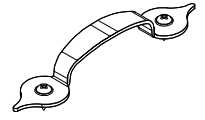

**A4M00627 DOOR HANDLE KIT**  
(x1)

**TIP:**  
**INSTALL T-NUTS IN WOOD FIRST**  
**ALIGN PILOT HOLES ON H03.**

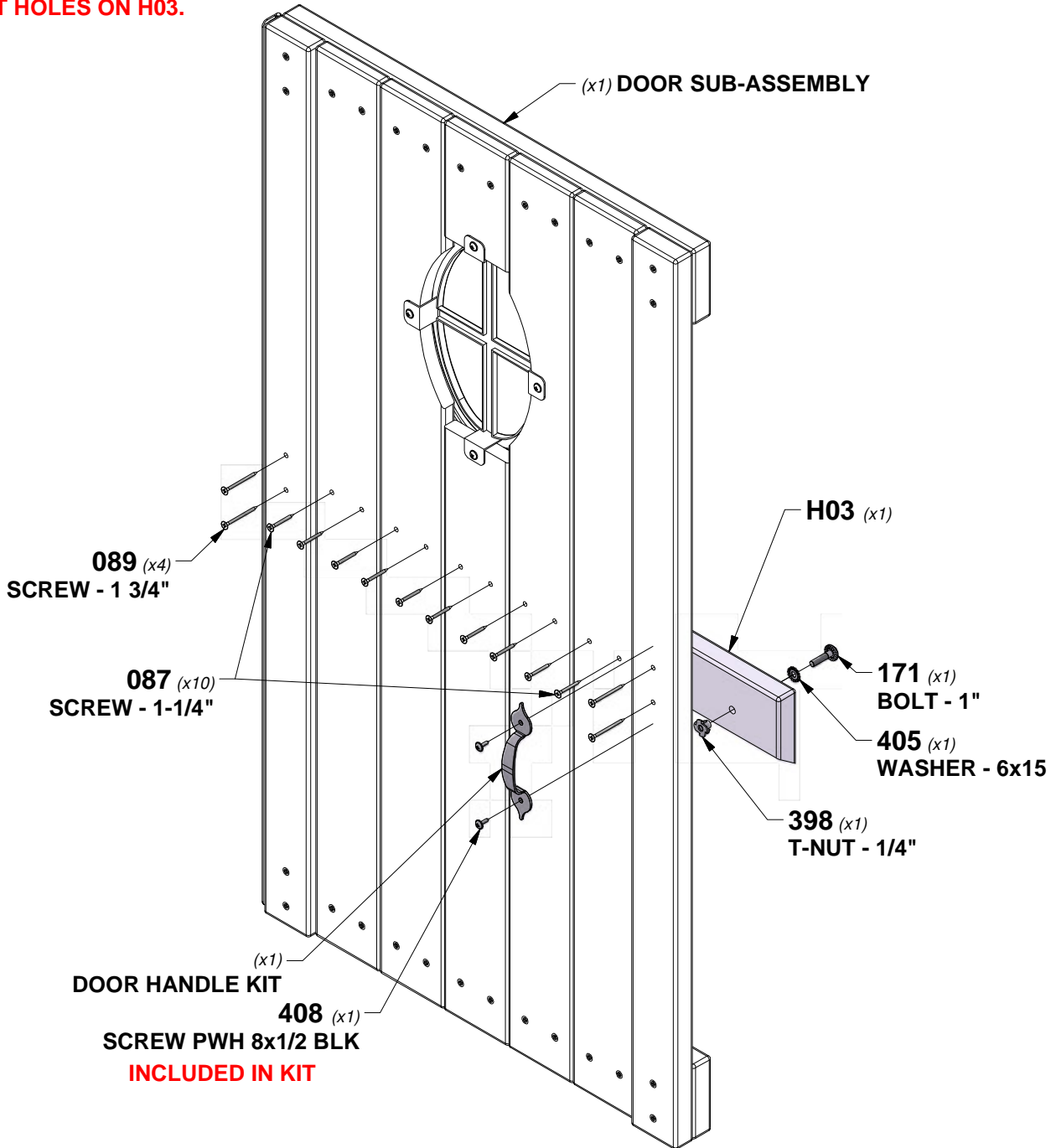

# STEP 54 - FORT ASSEMBLY

QTY	PART NUMBER	DESCRIPTION
13	H101191	SCREW PFH 6x1 BLK

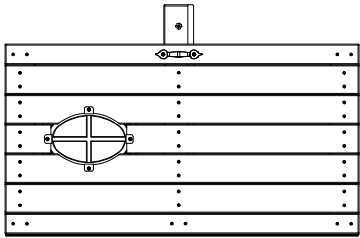

(x1) DOOR ASSEMBLY

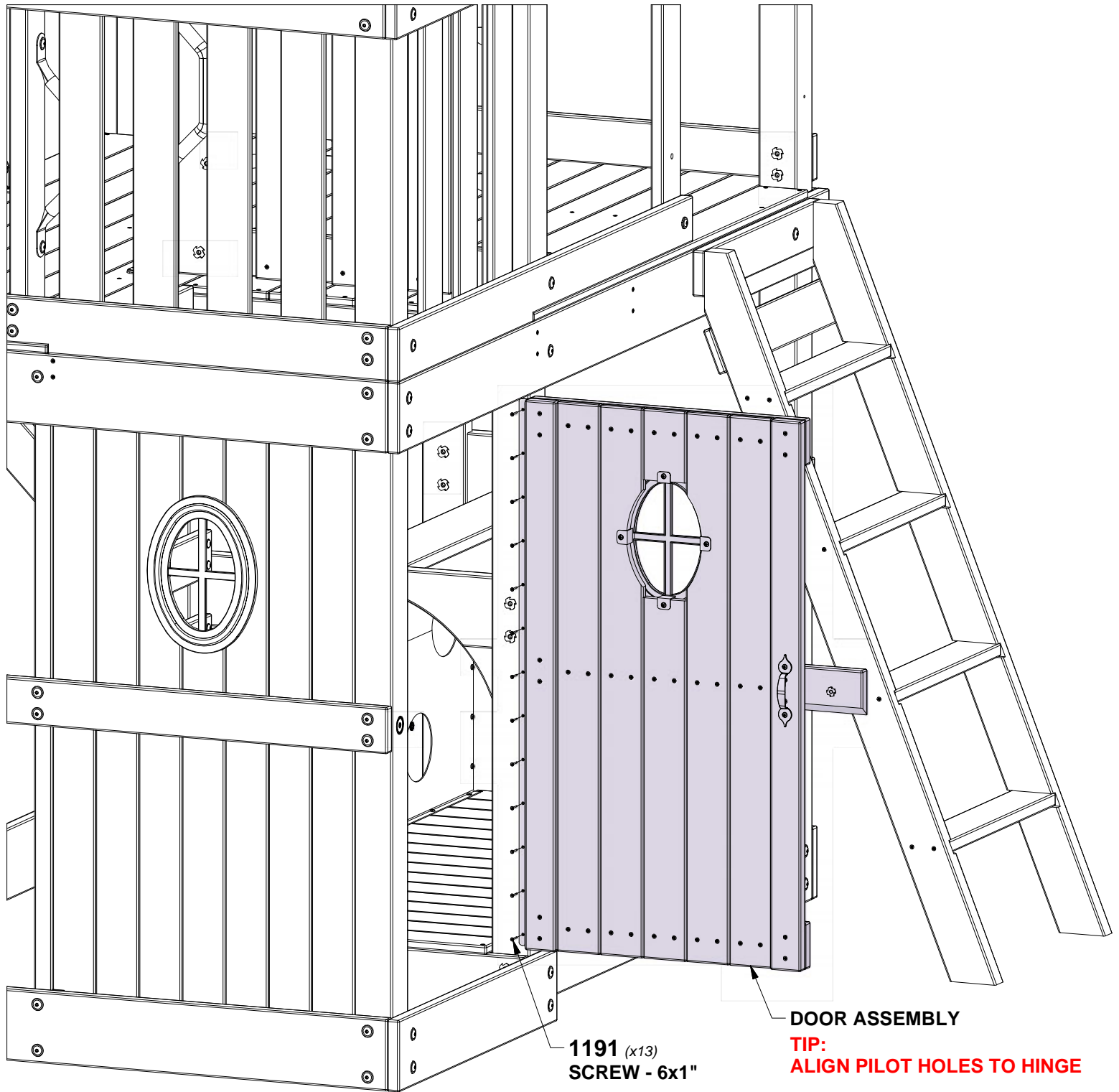

**1191 (x13)**  
**SCREW - 6x1"**

**DOOR ASSEMBLY**  
**TIP:**  
**ALIGN PILOT HOLES TO HINGE**

# STEP 55 - FORT ASSEMBLY

QTY	PART NUMBER	DESCRIPTION
12	H100087	SCREW PFH 8x1-1/4"



**M09 PICKET - W4L17752**  
 (x3) 5/8"x3 3/8"x26 5/8" (16x86x675)

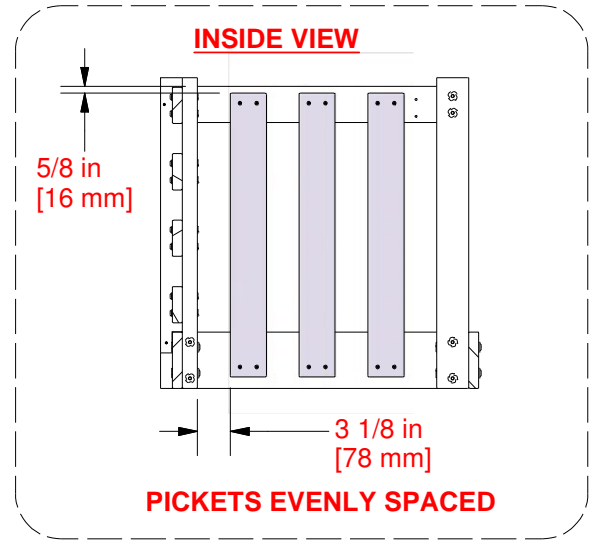
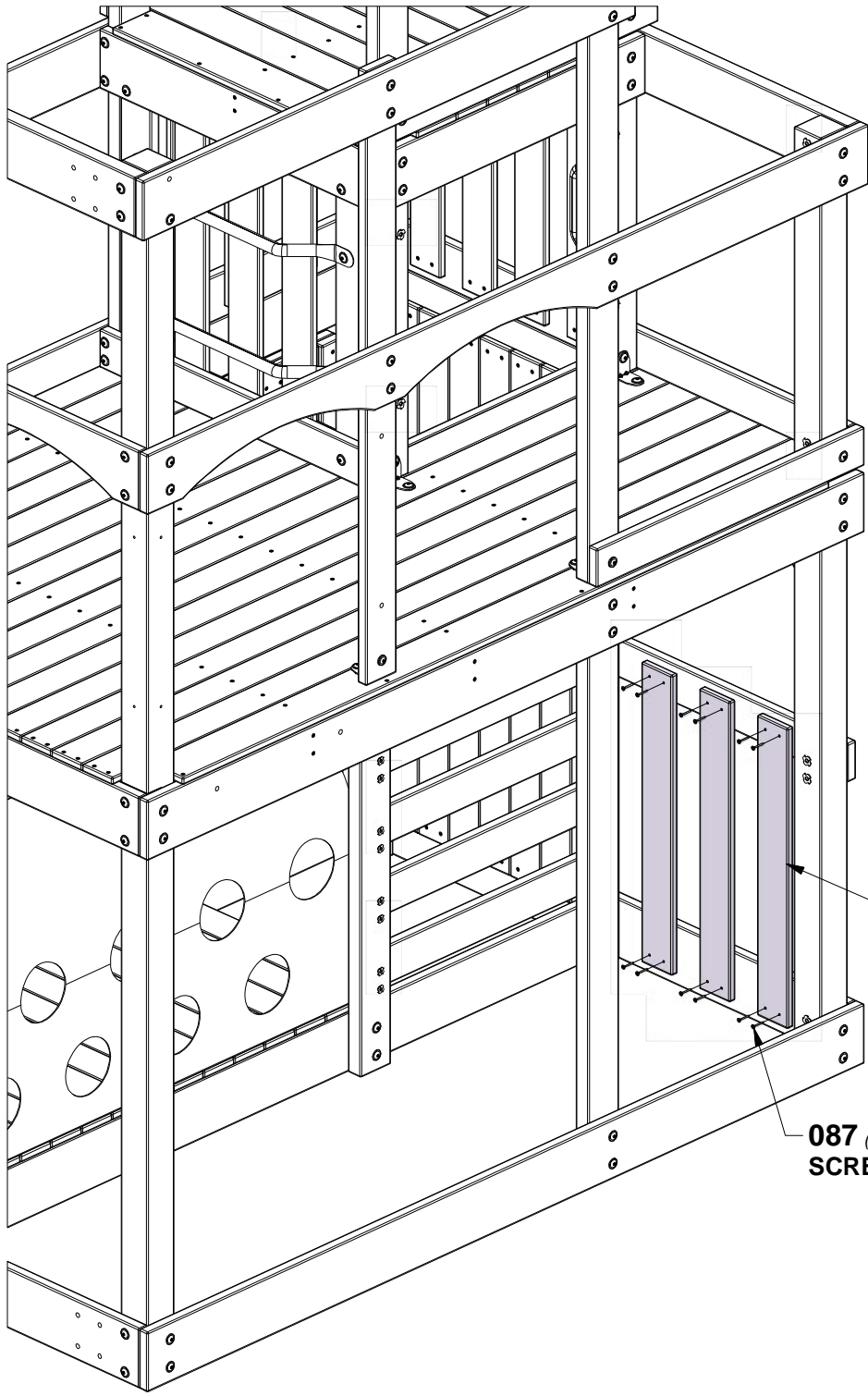

**M09 (x3)**

**087 (x12)**  
**SCREW - 1-1/4"**

# STEP 56 - FORT ASSEMBLY

QTY	PART NUMBER	DESCRIPTION
12	H100087	SCREW PFH 8x1-1/4"

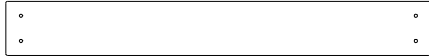

**M09 PICKET - W4L17752**  
 (x3) 5/8"x3 3/8"x26 5/8" (16x86x675)

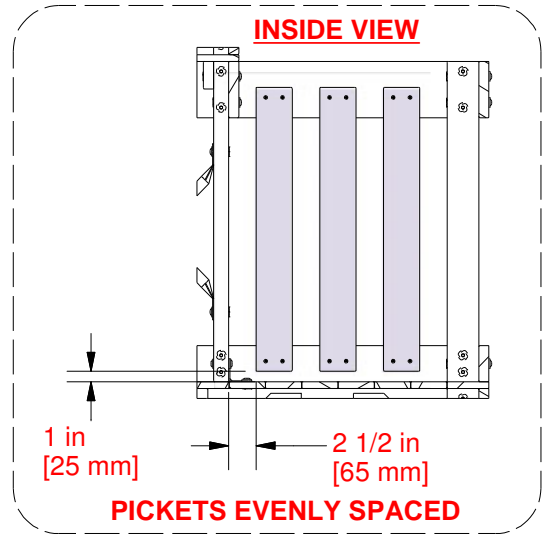
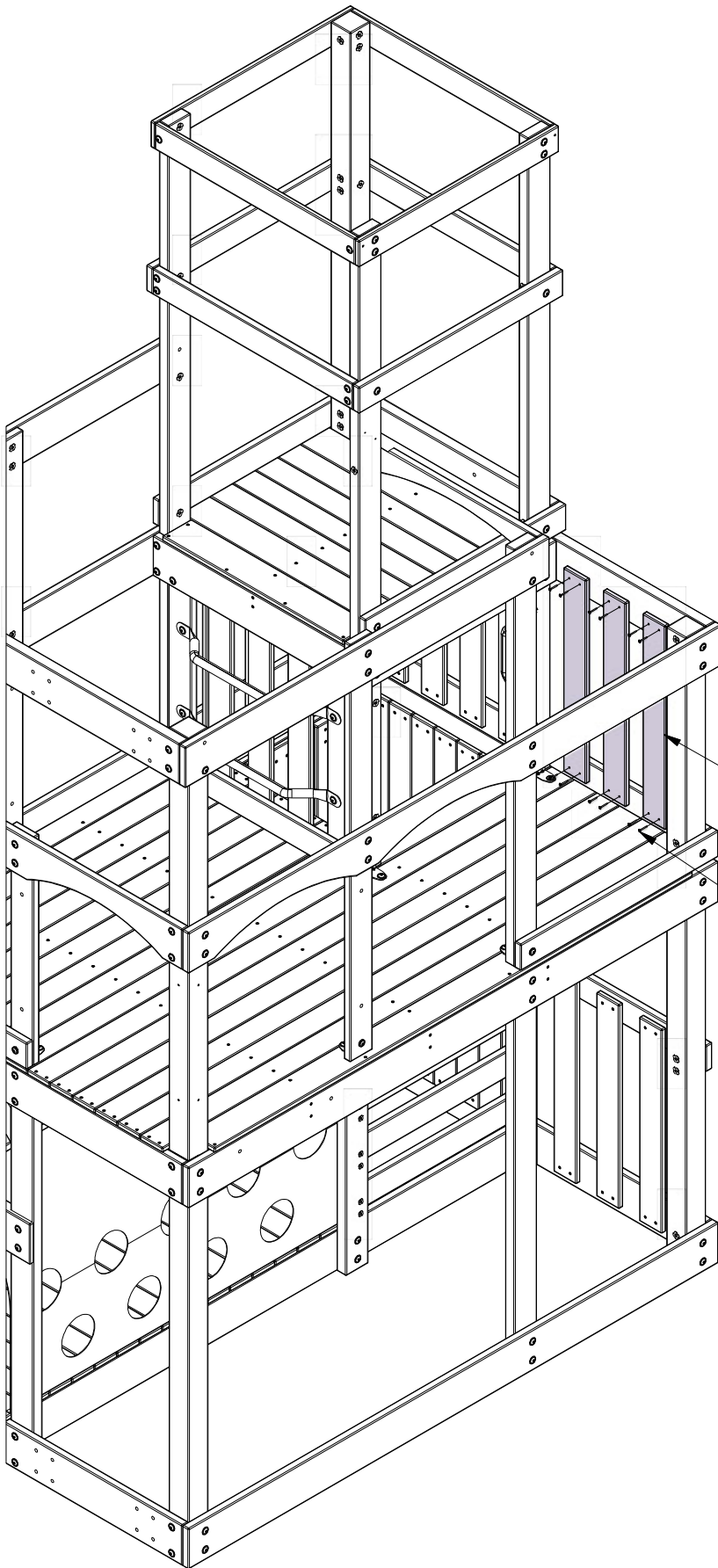

**M09 (x3)**

**087 (x12)**  
**SCREW - 1-1/4"**

# STEP 57 - FORT ASSEMBLY

QTY	PART NUMBER	DESCRIPTION
12	H100087	SCREW PFH 8x1-1/4"

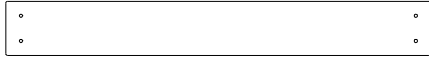

**M09 PICKET - W4L17752**  
(x3) 5/8"x3 3/8"x26 5/8" (16x86x675)

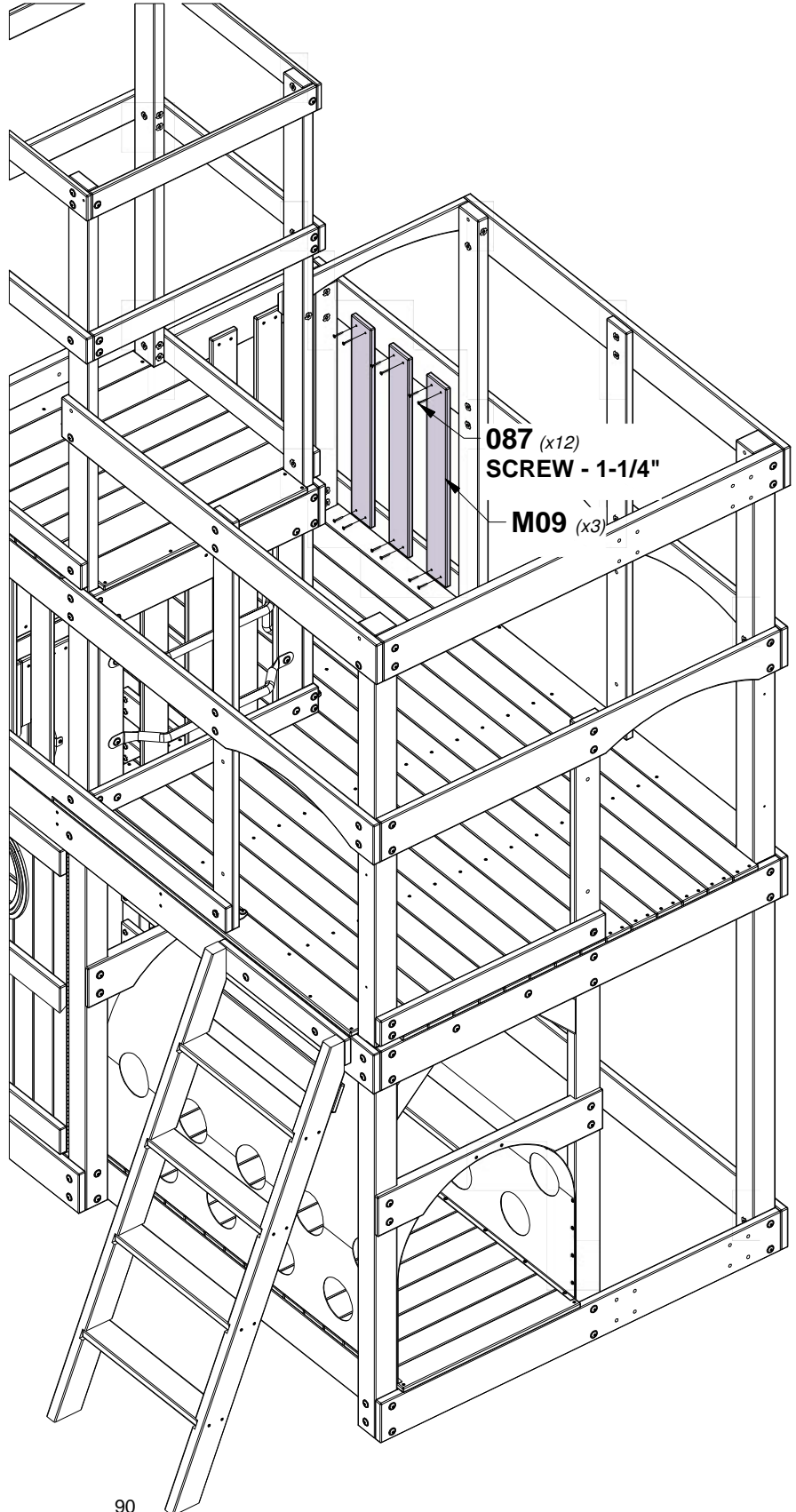
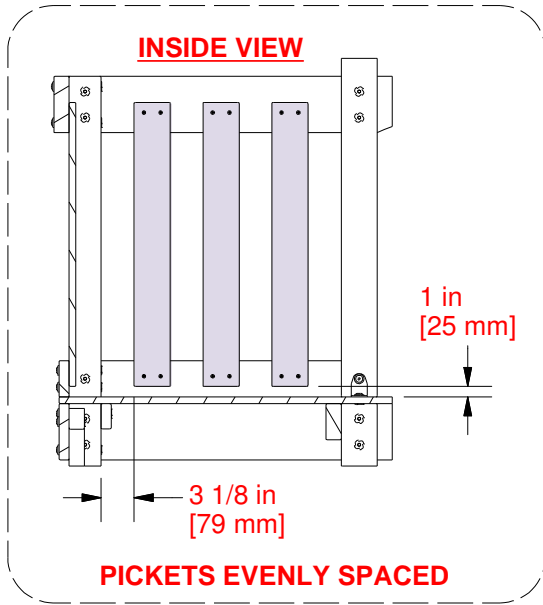



# STEP 58 - FORT ASSEMBLY

QTY	PART NUMBER	DESCRIPTION
12	H100087	SCREW PFH 8x1-1/4"

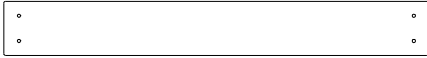

**M09 PICKET - W4L17752**  
 (x3) 5/8"x3 3/8"x26 5/8" (16x86x675)

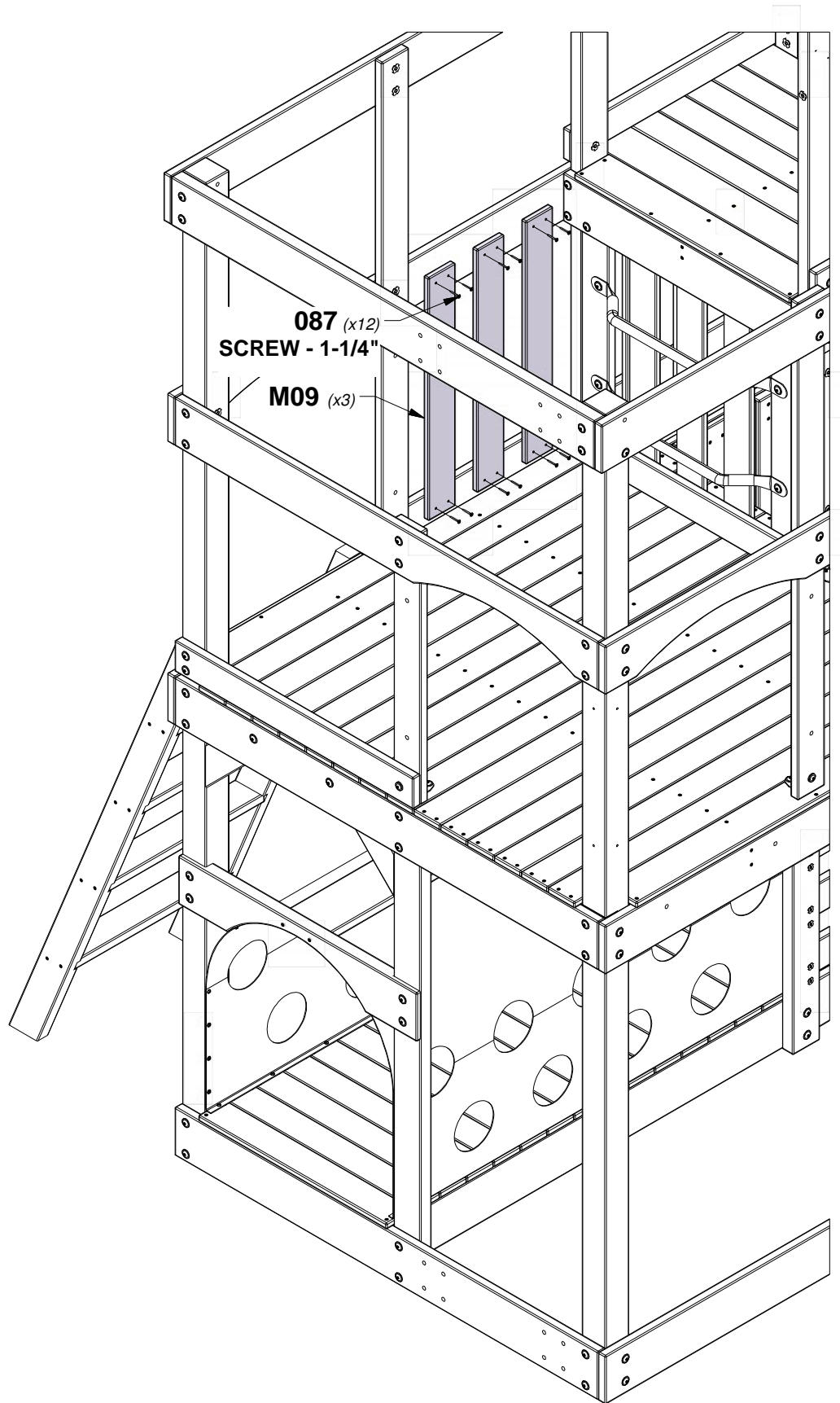
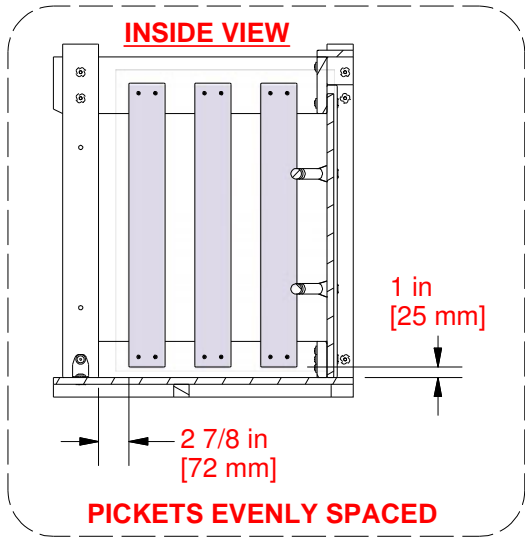

# STEP 59 - FORT ASSEMBLY

QTY	PART NUMBER	DESCRIPTION
16	H100087	SCREW PFH 8x1-1/4"

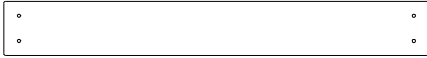

**M09 PICKET - W4L17752**  
 (x4) 5/8"x3 3/8"x26 5/8" (16x86x675)

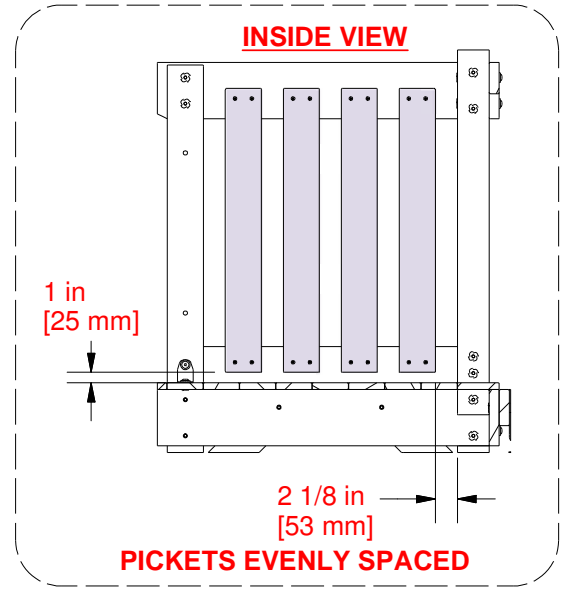
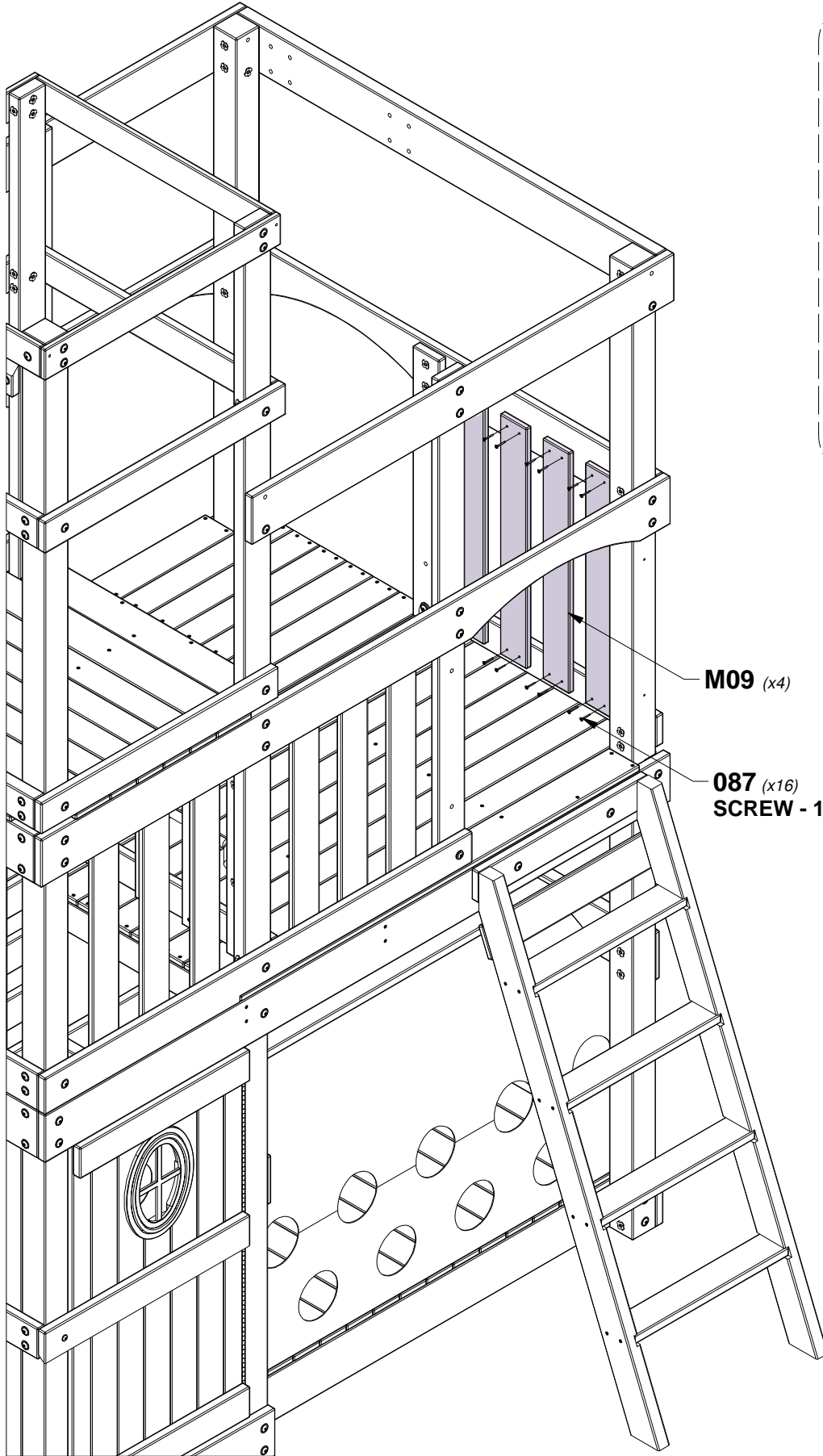

**M09 (x4)**

**087 (x16)  
 SCREW - 1-1/4"**



# STEP 60 - FORT ASSEMBLY

QTY	PART NUMBER	DESCRIPTION
24	H100087	SCREW PFH 8x1-1/4"
2	H100379	T-NUT 5/16 BLK



**M12 WALL BOARD - W4L17773**  
(x6) 5/8"x3 3/8"x31 3/4" (16x86x808)

**TIP:**  
**INSTALL T-NUTS IN WOOD FIRST**

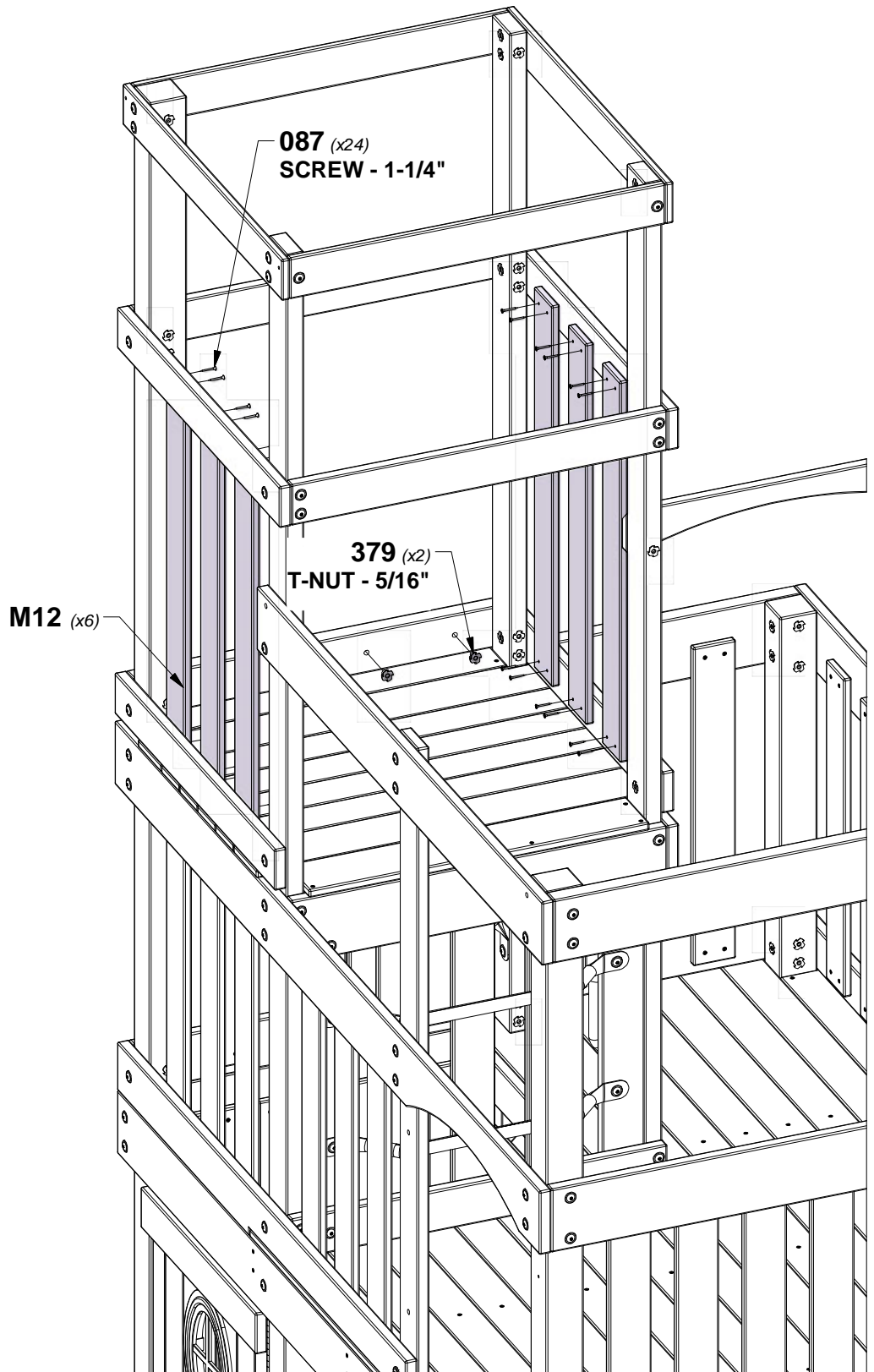
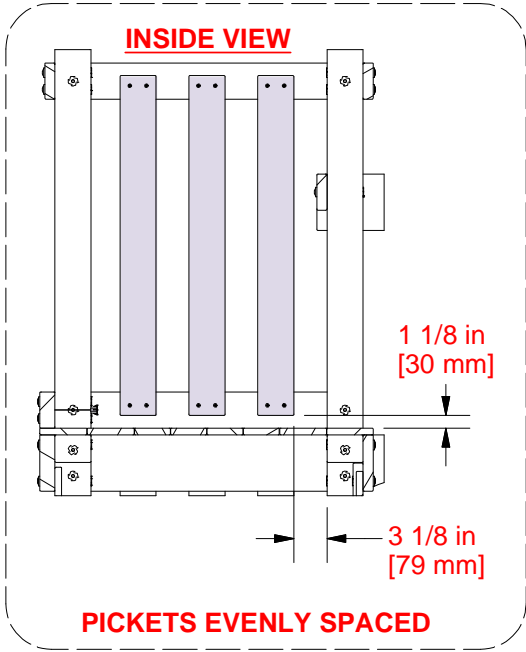

# STEP 61 - FORT ASSEMBLY

QTY	PART NUMBER	DESCRIPTION
16	H100087	SCREW PFH 8x1-1/4"



**M12 WALL BOARD - W4L17773**  
(x4) 5/8"x3 3/8"x31 3/4" (16x86x808)

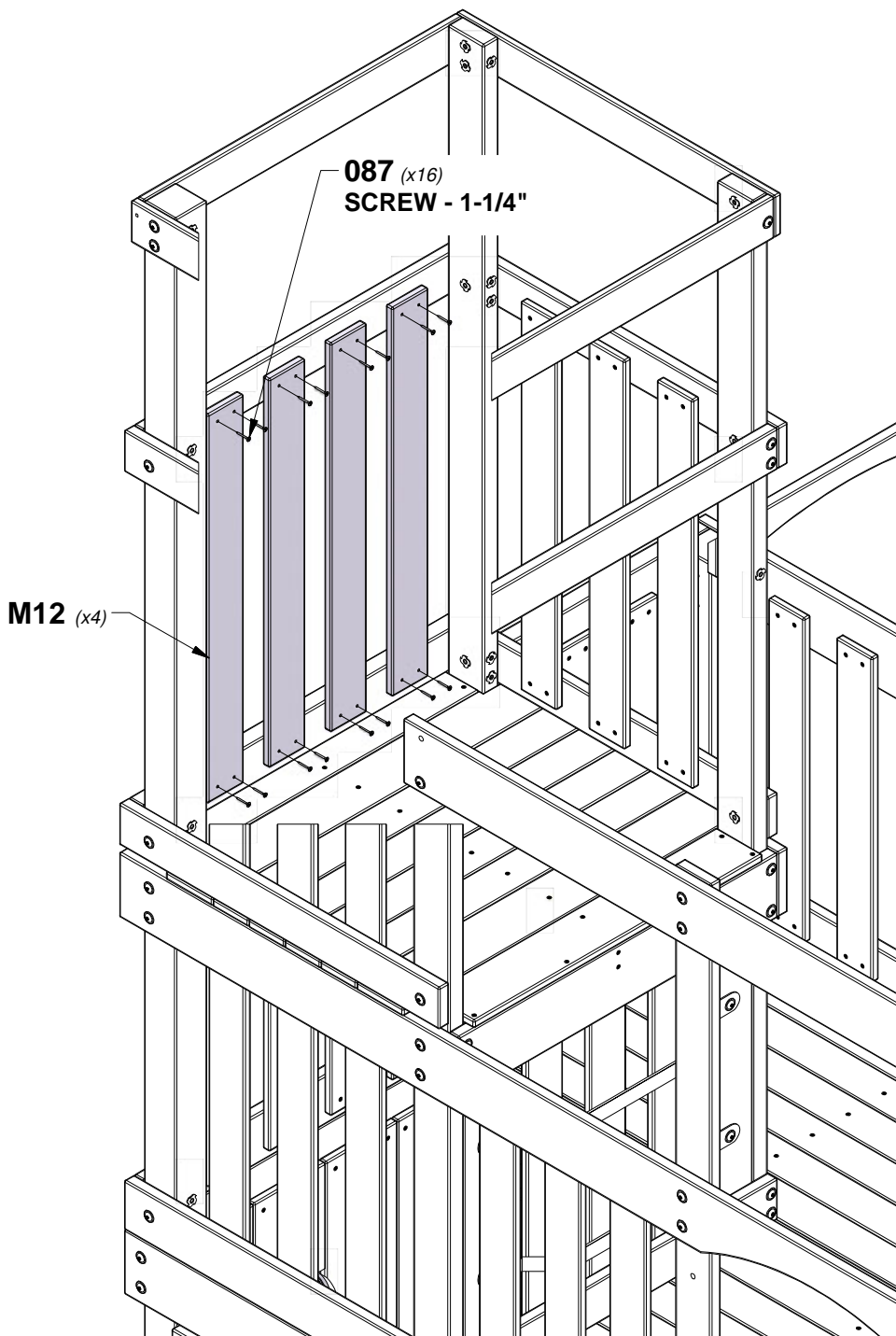
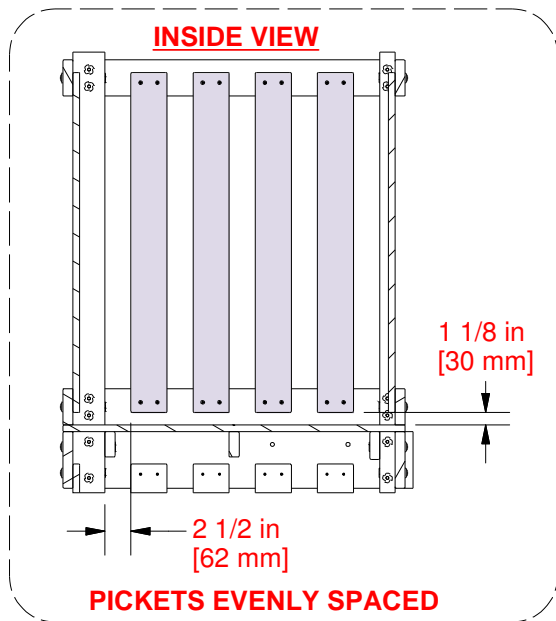

# STEP 62 - FORT ASSEMBLY

QTY	PART NUMBER	DESCRIPTION
24	H100087	SCREW PFH 8x1-1/4"
6	H100088	SCREW PFH 8x1-1/8"

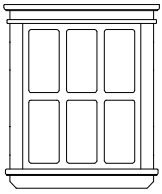

**A100321** PLASTIC WINDOW  
(x1) 44x412x485

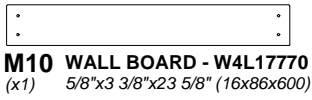

**M10** WALL BOARD - W4L17770  
(x1) 5/8"x3 3/8"x23 5/8" (16x86x600)

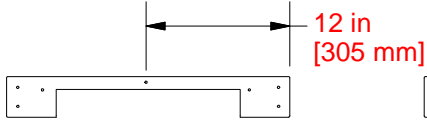

**M11** WALL BOARD - W4L17771  
(x2) 5/8"x3 3/8"x23 5/8" (16x86x600)



**M13** WALL BOARD - W4L17941  
(x1) 5/8"x3 3/8"x23 5/8" (16x86x600)



**Y04** WALL BOARD - W4L17772  
(x4) 5/8"x3 7/8"x4 1/8" (16x98x105)

## INSIDE VIEW

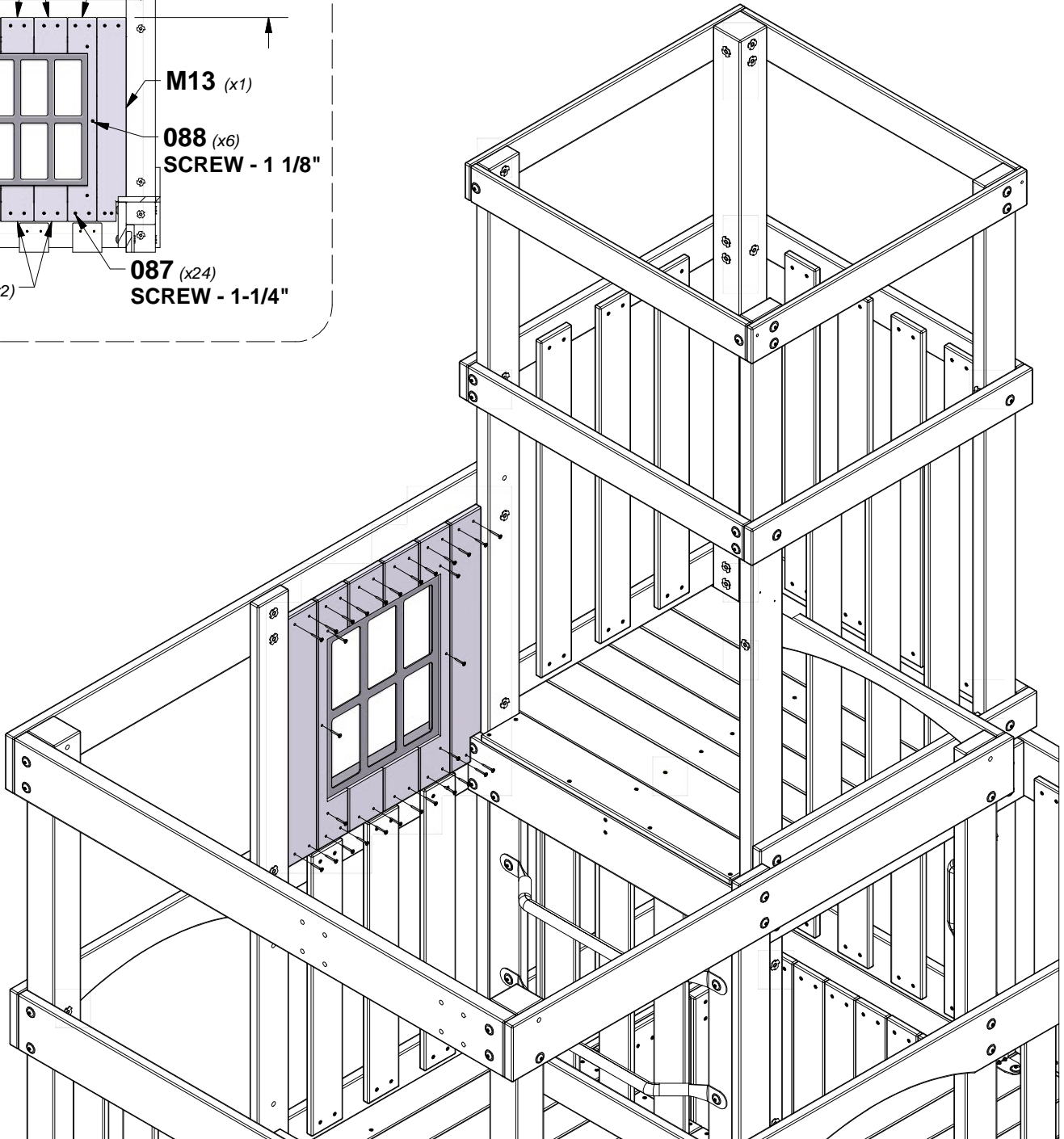
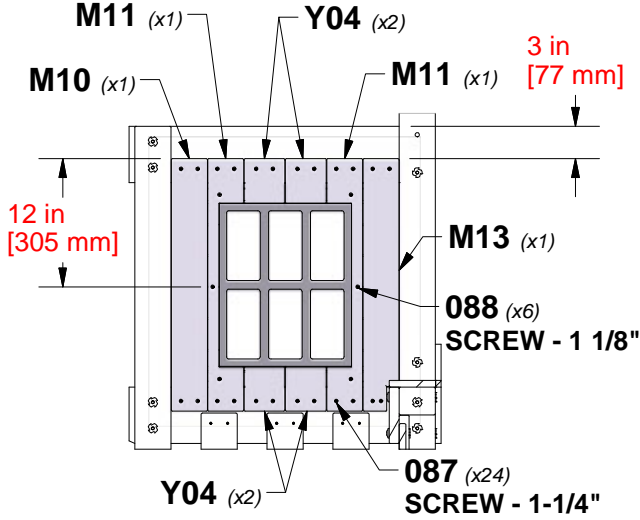

# STEP 63 - FORT ASSEMBLY

QTY	PART NUMBER	DESCRIPTION
48	H100087	SCREW PFH 8x1-1/4"
12	H100088	SCREW PFH 8x1-1/8"

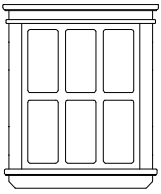

**A100321**  
(x2)  
**PLASTIC WINDOW**  
44x412x485



**M10 WALL BOARD - W4L17770**  
(x4) 5/8"x3 3/8"x23 5/8" (16x86x600)

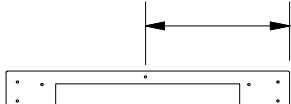

12 in  
[305 mm]

**M11 WALL BOARD - W4L17771**  
(x4) 5/8"x3 3/8"x23 5/8" (16x86x600)



**Y04 WALL BOARD - W4L17772**  
(x8) 5/8"x3 7/8"x4 1/8" (16x98x105)

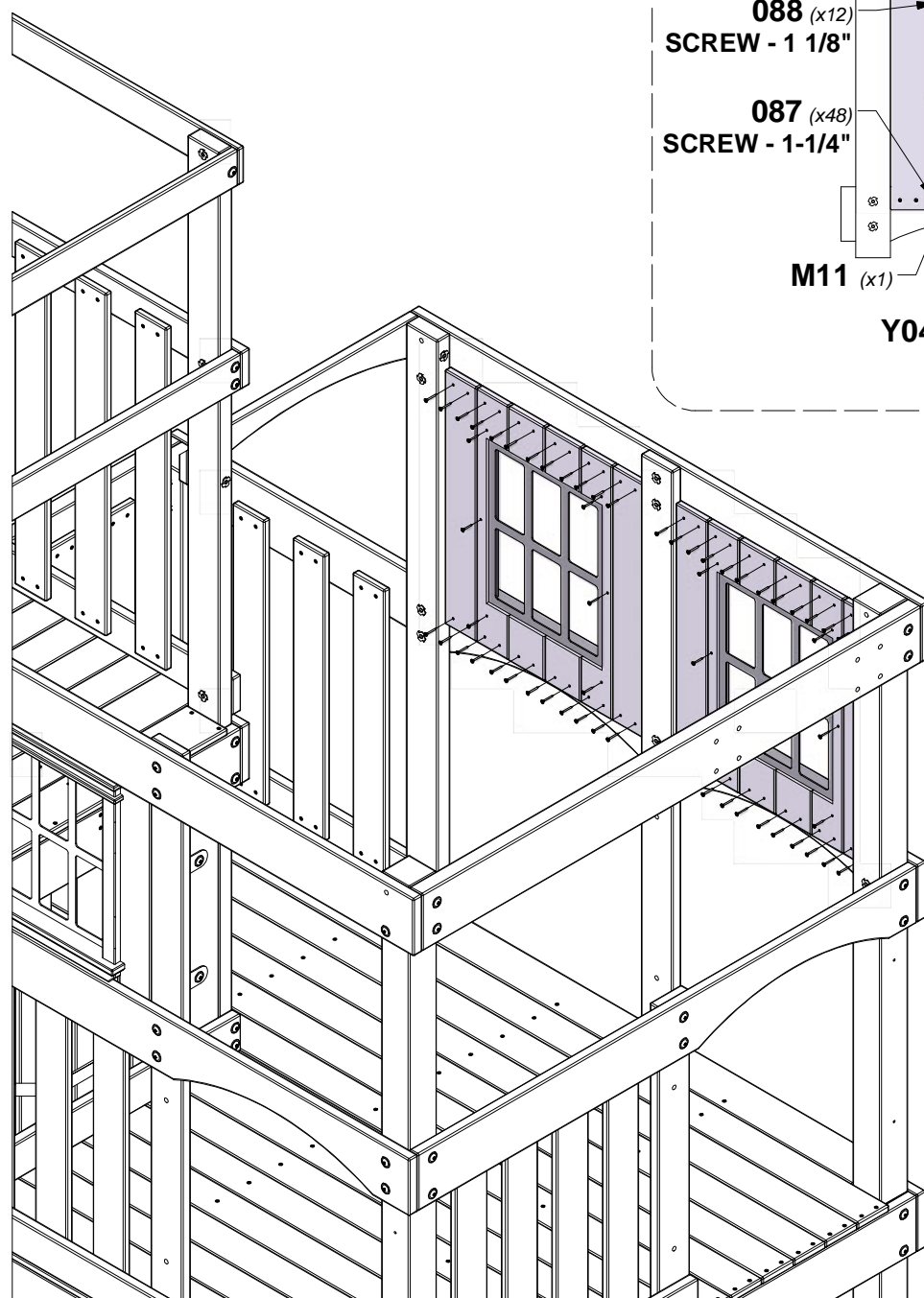
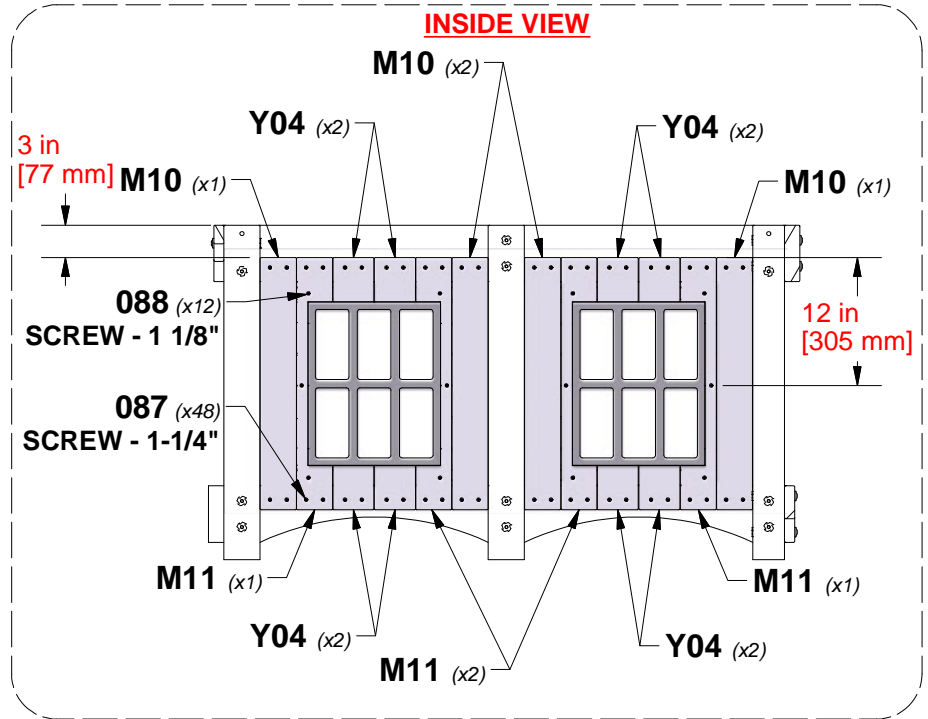

# STEP 64 - FORT ASSEMBLY

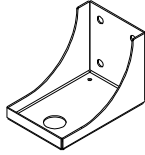

**A4M02061 ROPE LADDER BRACKET**  
(x4)

QTY	PART NUMBER	DESCRIPTION
16	H100379	T-NUT 5/16 BLK
16	H100477	WASHER SPLIT 5/16 BLK
16	H100478	WASHER FLAT 8x27 BLK
8	H100481	BOLT HEX 5/16x1 1/4 BLK
8	H100657	BOLT HEX 5/16x1 3/4 BLK

**TIP:**  
**INSTALL T-NUTS IN WOOD FIRST**

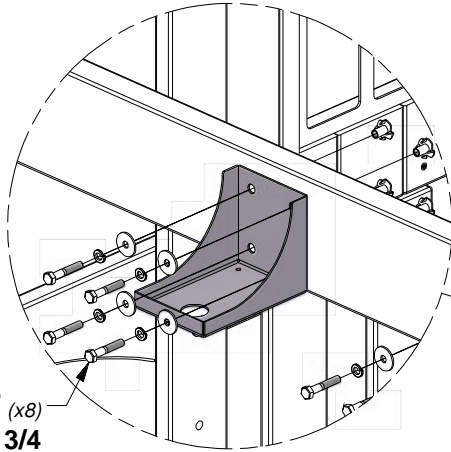

**657 (x8)**  
**BOLT - 5/16x1 3/4**

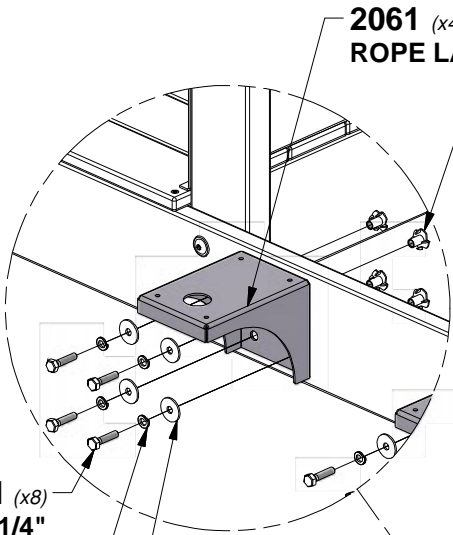

**2061 (x4)**  
**ROPE LADDER BRACKET**

**379 (x16)**  
**T-NUT - 5/16"**

**481 (x8)**  
**BOLT - 1 1/4"**

**477 (x16)**  
**WASHER - 5/16**

**478 (x16)**  
**WASHER - 8x27**

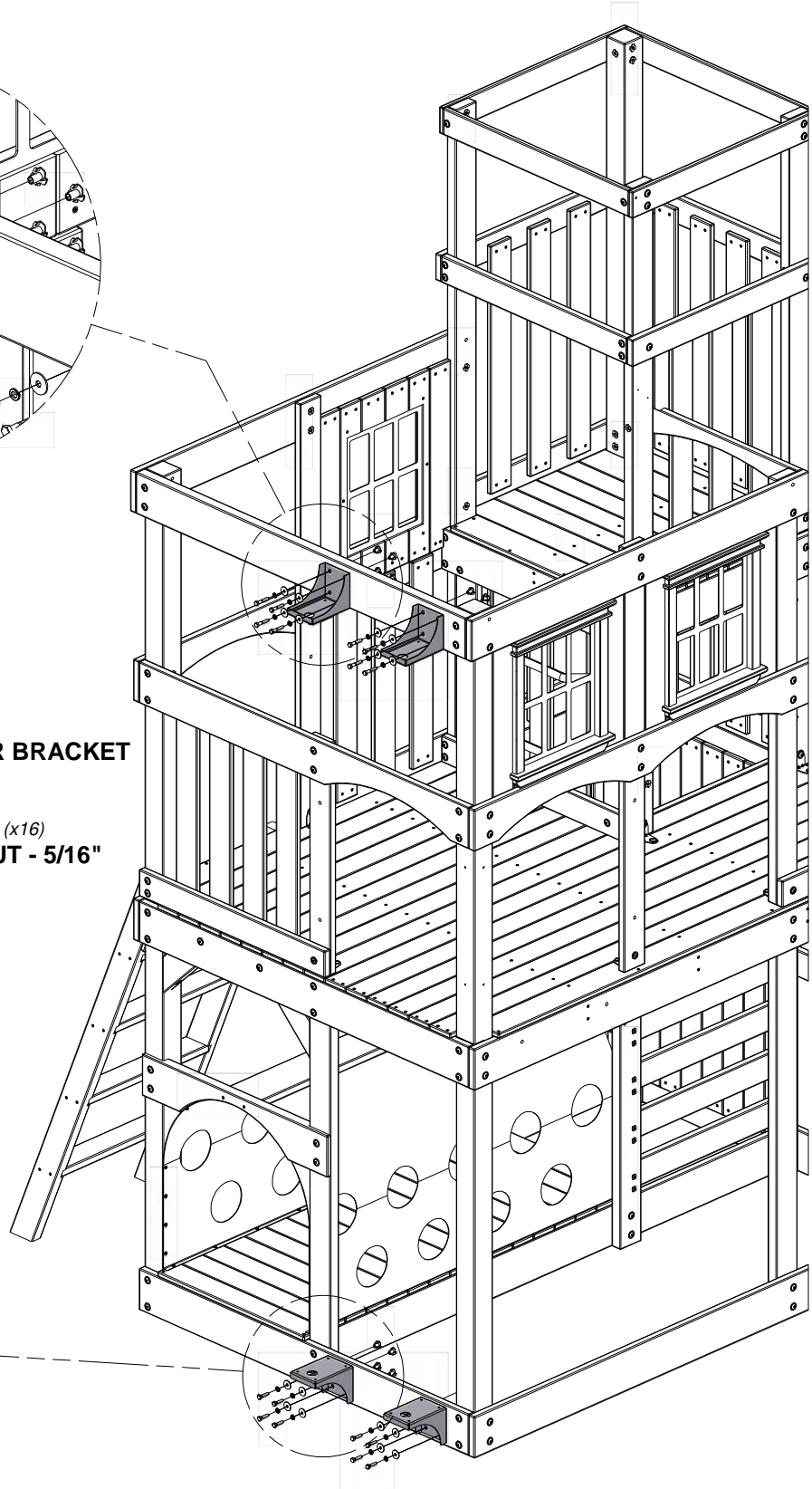

# STEP 1 - ROPE CLAMP ASSEMBLY

ROPE CLAMP ATTACHED IN NEXT STEP.

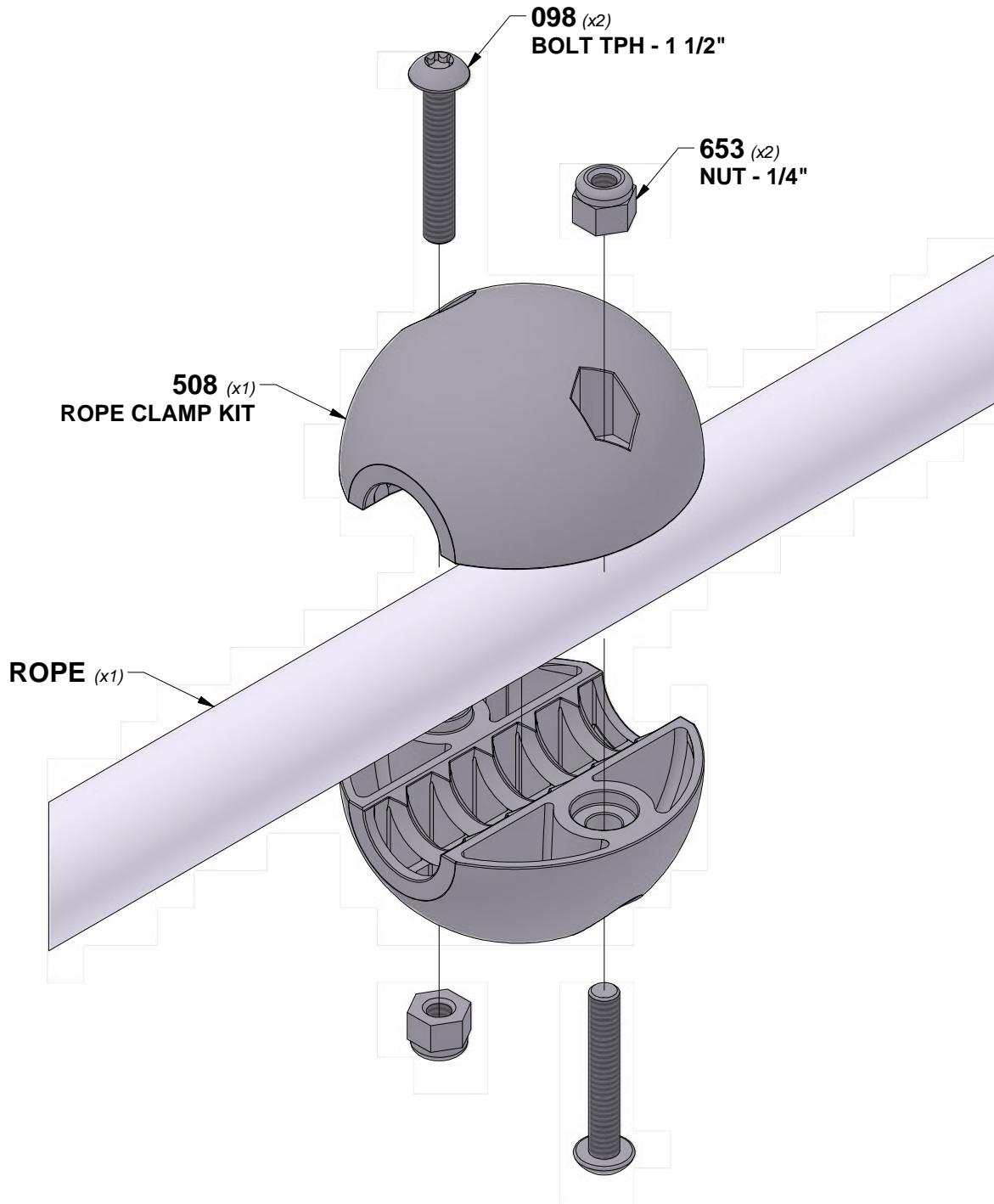



# STEP 65 - FORT ASSEMBLY

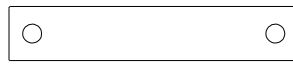

**H22 LADDER RUNG - W4L17915**  
(x4) 1"x3 3/8"x18 1/8" (24x86x460)

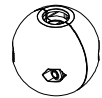

**A6P00508 ROPE CLAMP KIT**  
(x12)

**A6P00564 ROPE**  
(x2)

## FRONT VIEW

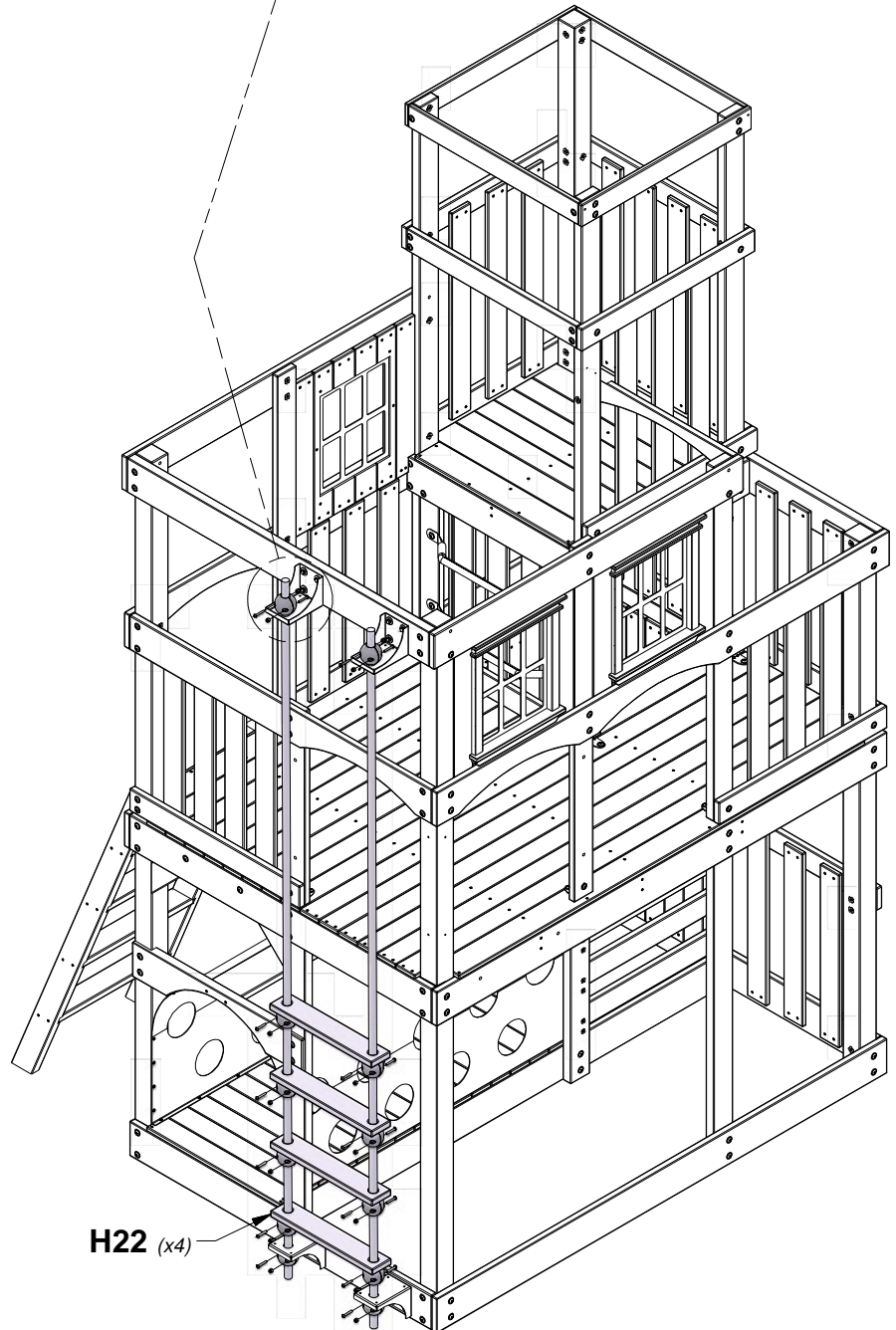
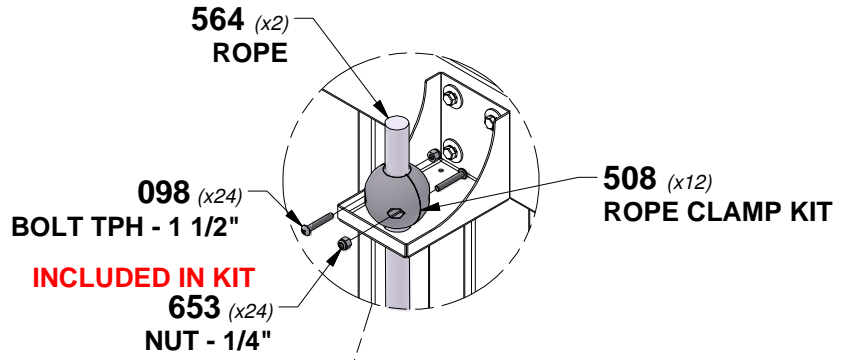
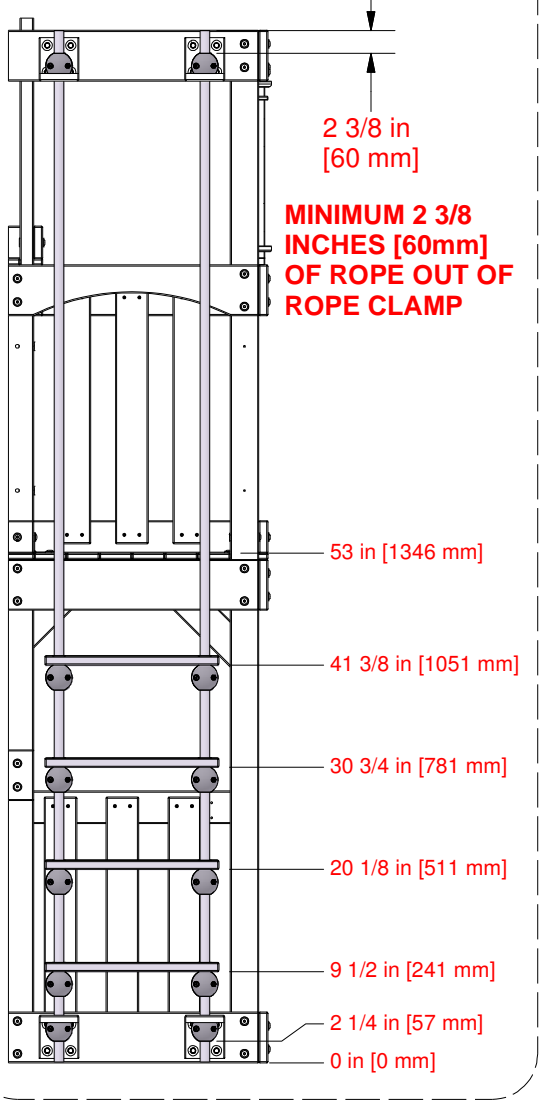

# STEP 66 - FORT ASSEMBLY

QTY	PART NUMBER	DESCRIPTION
4	H100198	WASHER LOCK EXT 8x19 BLK
4	H100458	LAG SCREW WH 5/16x2 BLK

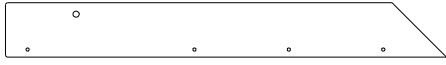

**H25 ROOF RAFTER - W4L17918**  
(x4) 1"x3 3/8"x27 1/2" (24x86x700)

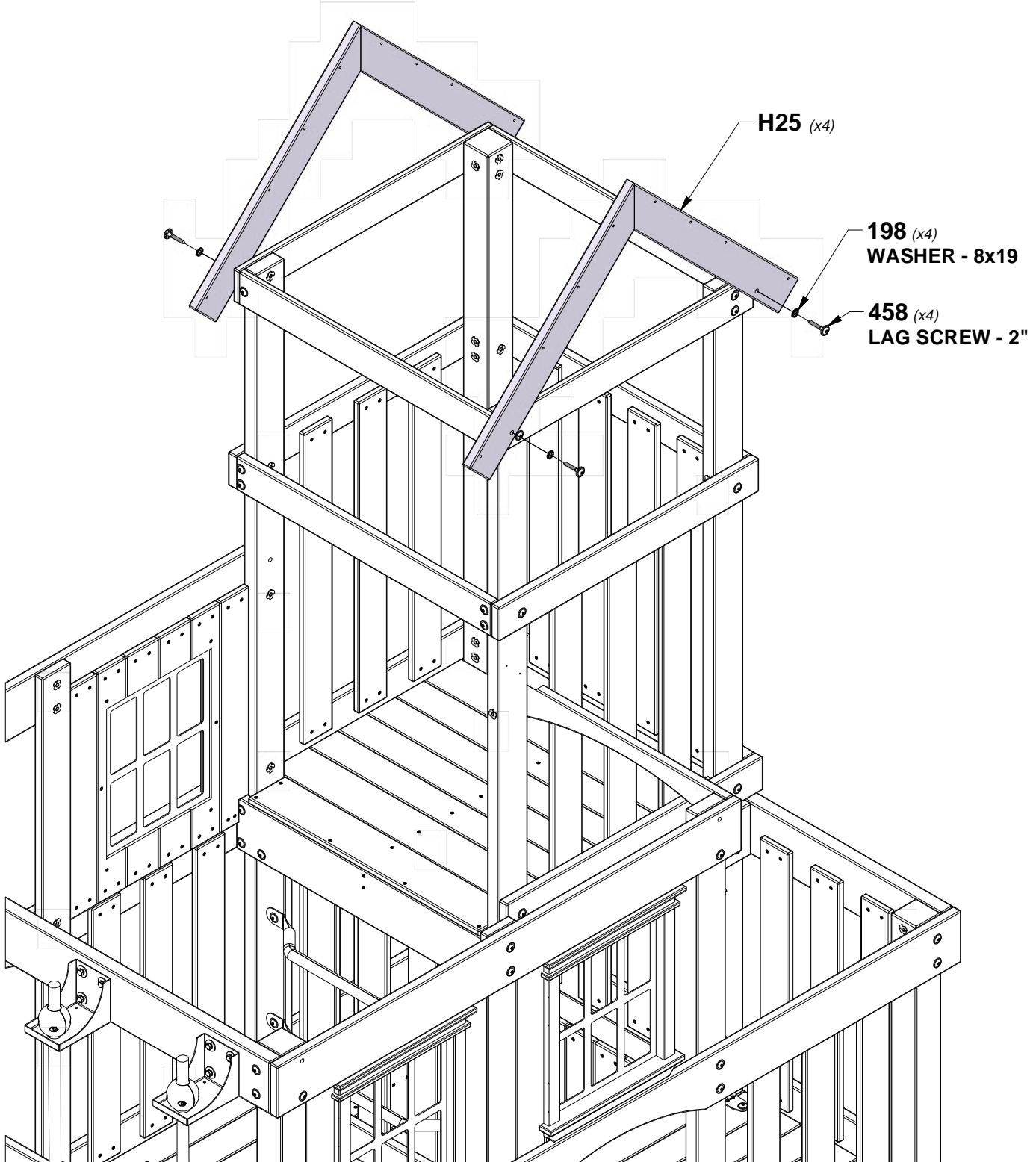



# STEP 67 - FORT ASSEMBLY

QTY	PART NUMBER	DESCRIPTION
12	H100087	SCREW PFH 8x1-1/4"
8	H100392	SCREW PWH 8x3/4 BLK

**J03 GABLE BOARD - W4L17978**  
(x2) 1"x2 3/8"x9 5/8" (24x60x245)

**N04 GABLE BOARD - W4L17920**  
(x2) 5/8"x2 3/8"x25 5/8" (16x60x650)

**A4M02100 GABLE CLEAT**  
(x2)

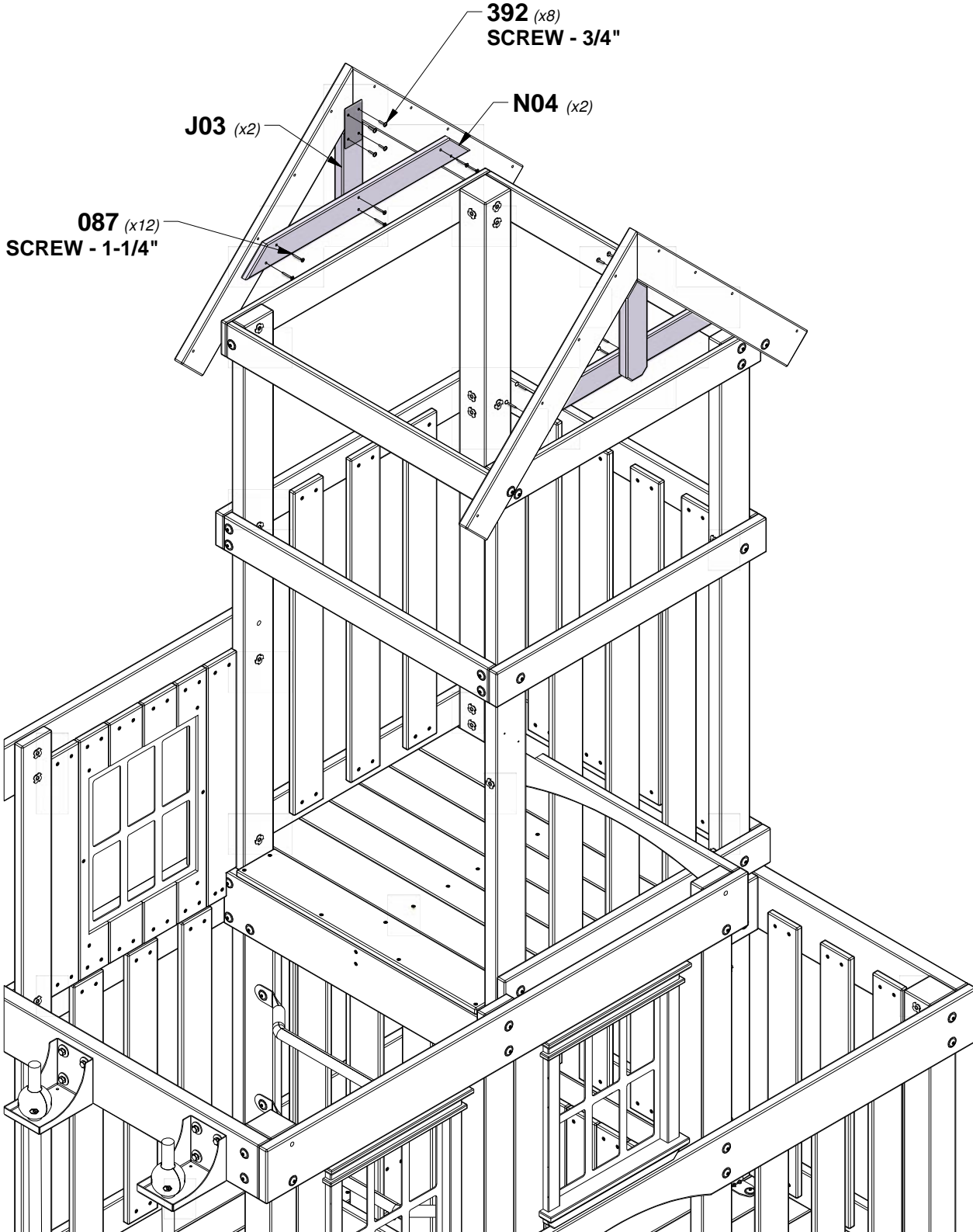

# STEP 68 - FORT ASSEMBLY

QTY	PART NUMBER	DESCRIPTION
8	H100391	SCREW PFH 8x2 BLK

•	•
•	•
•	•
•	•
•	•

:	:
•	•
•	•
•	•
•	•

**RP5 ROOF PANEL - W2A03760**  
 (x1) 1 5/8"x15 5/8"x59" (42x396x974)

**RP6 PEAK ROOF PANEL - W2A03761**  
 (x1) 1 5/8"x13 3/8"x62 1/2" (42x341x974)

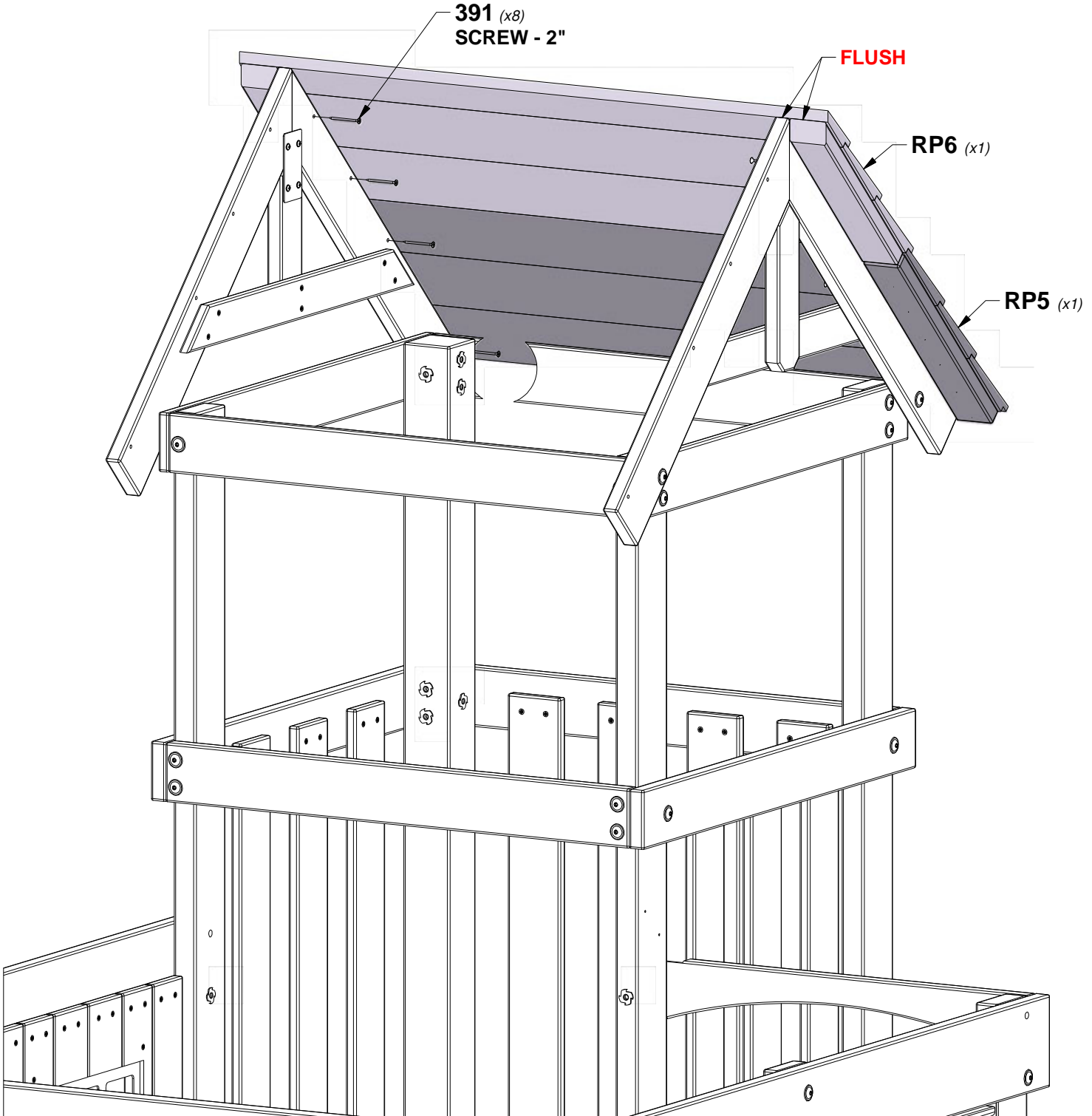

# STEP 69 - FORT ASSEMBLY

QTY	PART NUMBER	DESCRIPTION
8	H100391	SCREW PFH 8x2 BLK

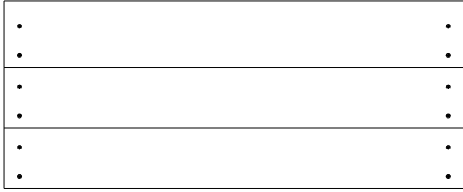

**RP5 ROOF PANEL - W2A03760**  
(x1) 1 5/8"x15 5/8"x59" (42x396x974)

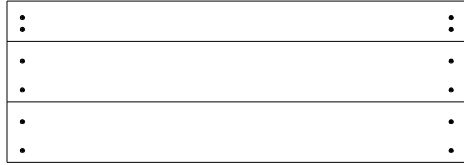

**RP6 PEAK ROOF PANEL - W2A03761**  
(x1) 1 5/8"x13 3/8"x62 1/2" (42x341x974)

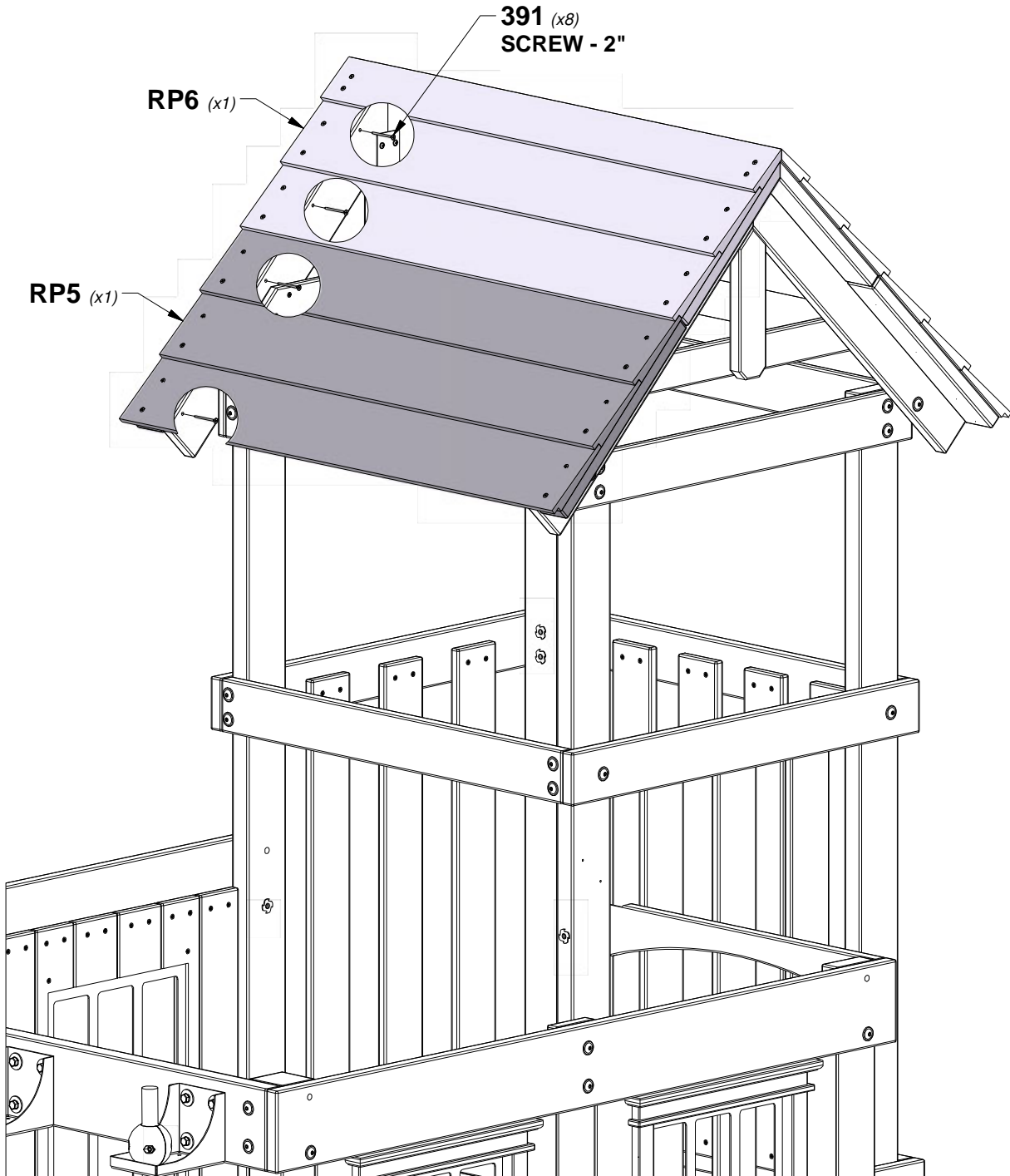

# STEP 70 - FORT ASSEMBLY

QTY	PART NUMBER	DESCRIPTION
4	H100198	WASHER LOCK EXT 8x19 BLK
4	H100379	T-NUT 5/16 BLK
2	H100480	BOLT WH 5/16x4 3/4 BLK
2	H100484	BOLT WH 5/16x3 1/4 BLK



**H24 ROOF RAFTER - W4L17774**  
 (x4) 1"x3 3/8"x42 5/8" (24x86x1083)

**TIP:**  
**INSTALL T-NUTS IN WOOD FIRST**

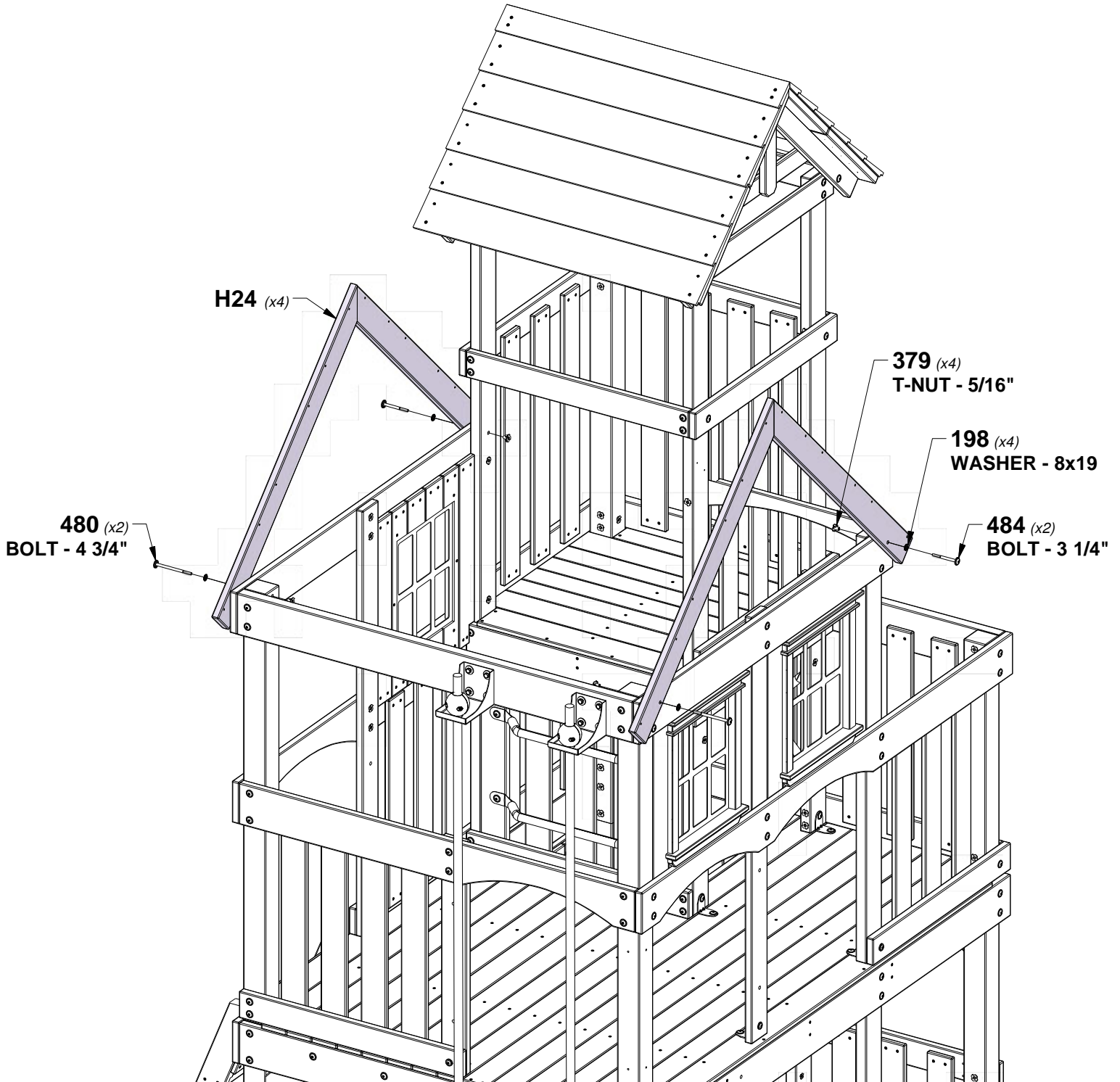

# STEP 71 - FORT ASSEMBLY

QTY	PART NUMBER	DESCRIPTION
32	H100087	SCREW PFH 8x1-1/4"

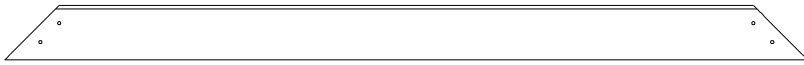

**K901 GABLE BOARD - W4L17968**  
(x2) 3/8"x3 3/8"x50 1/4" (11x86x1275)

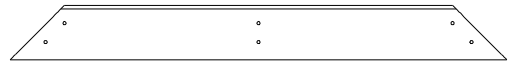

**K904 GABLE BOARD - W4L17971**  
(x2) 3/8"x3 3/8"x31 1/8" (11x86x789)

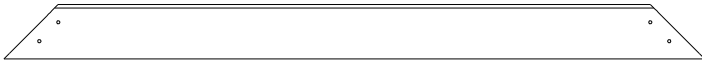

**K902 GABLE BOARD - W4L17969**  
(x2) 3/8"x3 3/8"x43 7/8" (11x86x1113)

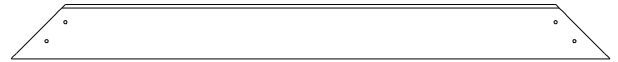

**K903 GABLE BOARD - W4L17970**  
(x2) 3/8"x3 3/8"x37 1/2" (11x86x951)

## INSIDE VIEW

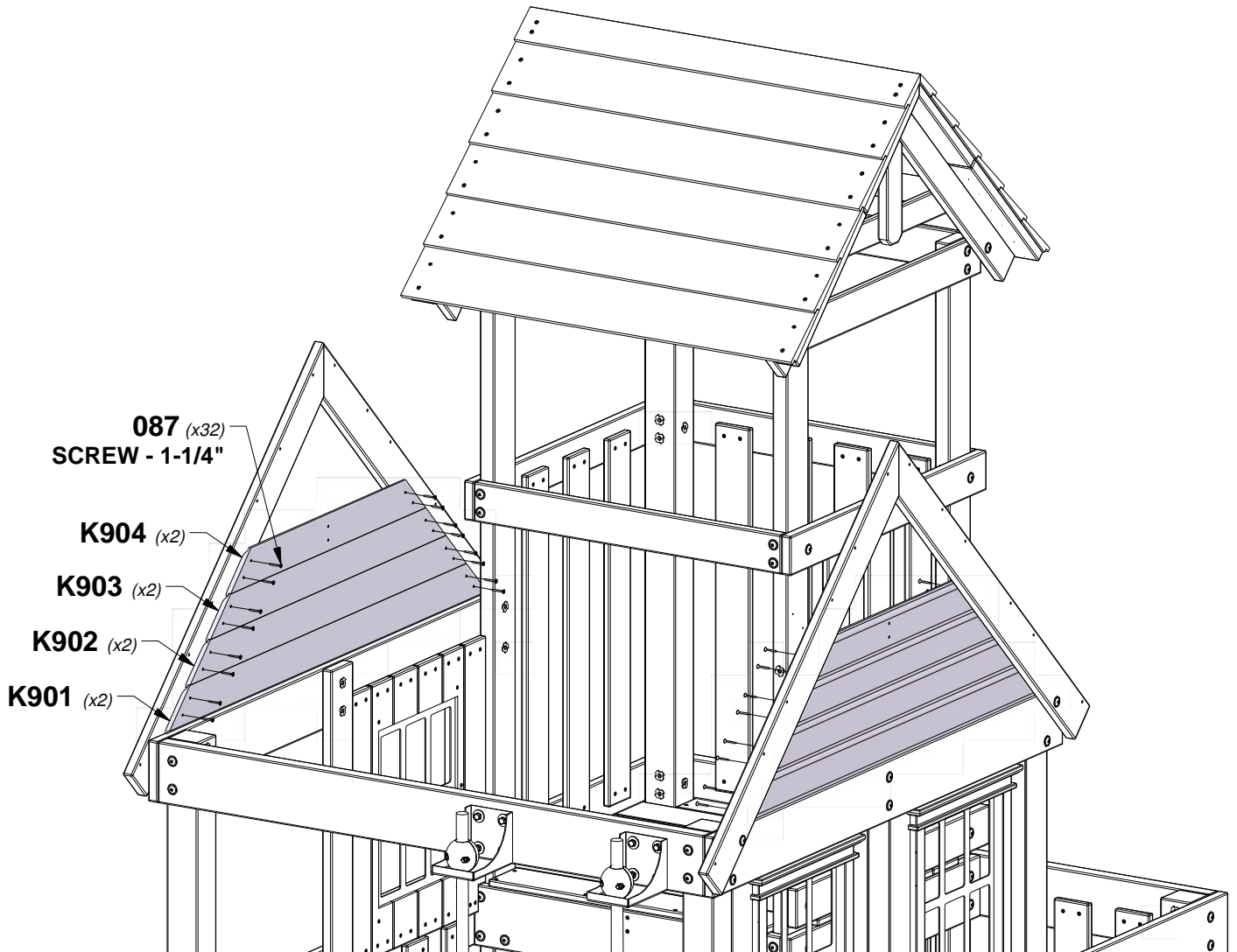
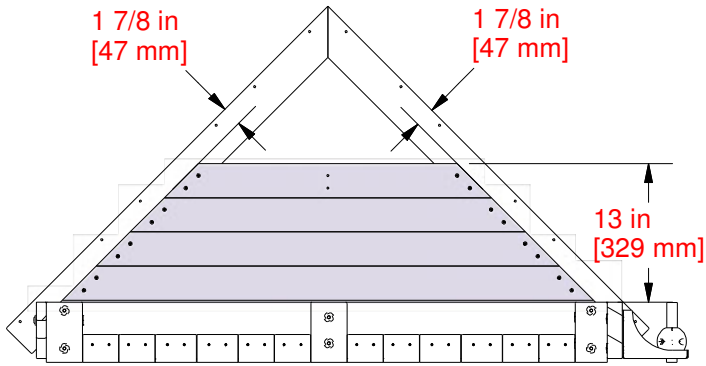

# STEP 72 - FORT ASSEMBLY

QTY	PART NUMBER	DESCRIPTION
12	H100087	SCREW PFH 8x1-1/4"
8	H100392	SCREW PWH 8x3/4 BLK



**N03 GABLE BOARD - W4L17919**  
(x4) 5/8"x2 3/8"x9" (16x60x230)



**J04 GABLE BOARD - W4L17921**  
(x2) 1"x2 3/8"x13" (24x60x330)

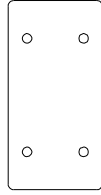

**A4M02100 GABLE CLEAT**  
(x2)

## INSIDE VIEW

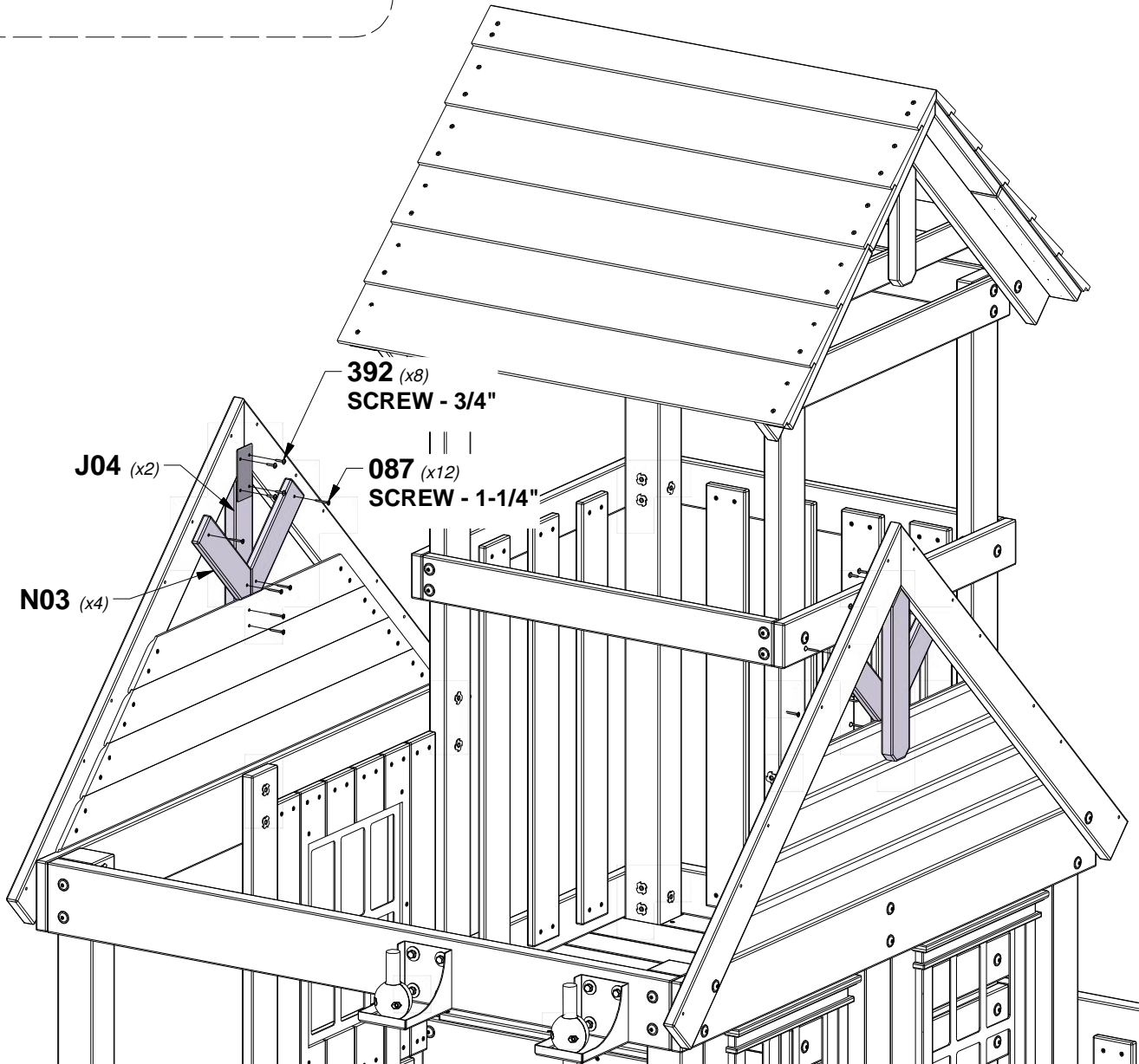
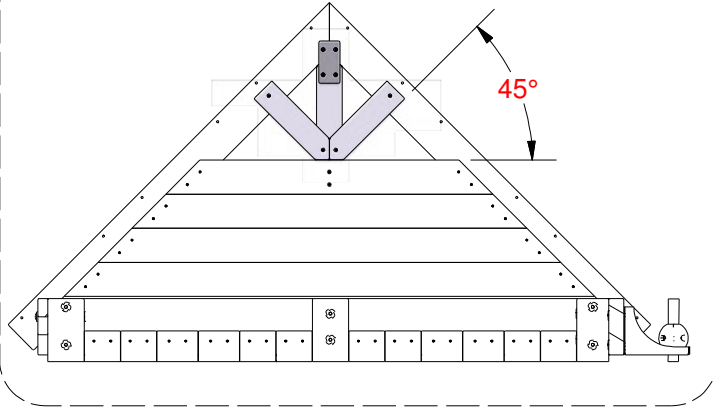



# STEP 73 - FORT ASSEMBLY

QTY	PART NUMBER	DESCRIPTION
4	H100391	SCREW PFH 8x2 BLK

:	:
.	.
.	.
.	.
.	.

**RP1 PEAK ROOF PANEL - W2A03756**  
(x1) 1 5/8"x13 3/8"x62 1/2" (42x341x1586)

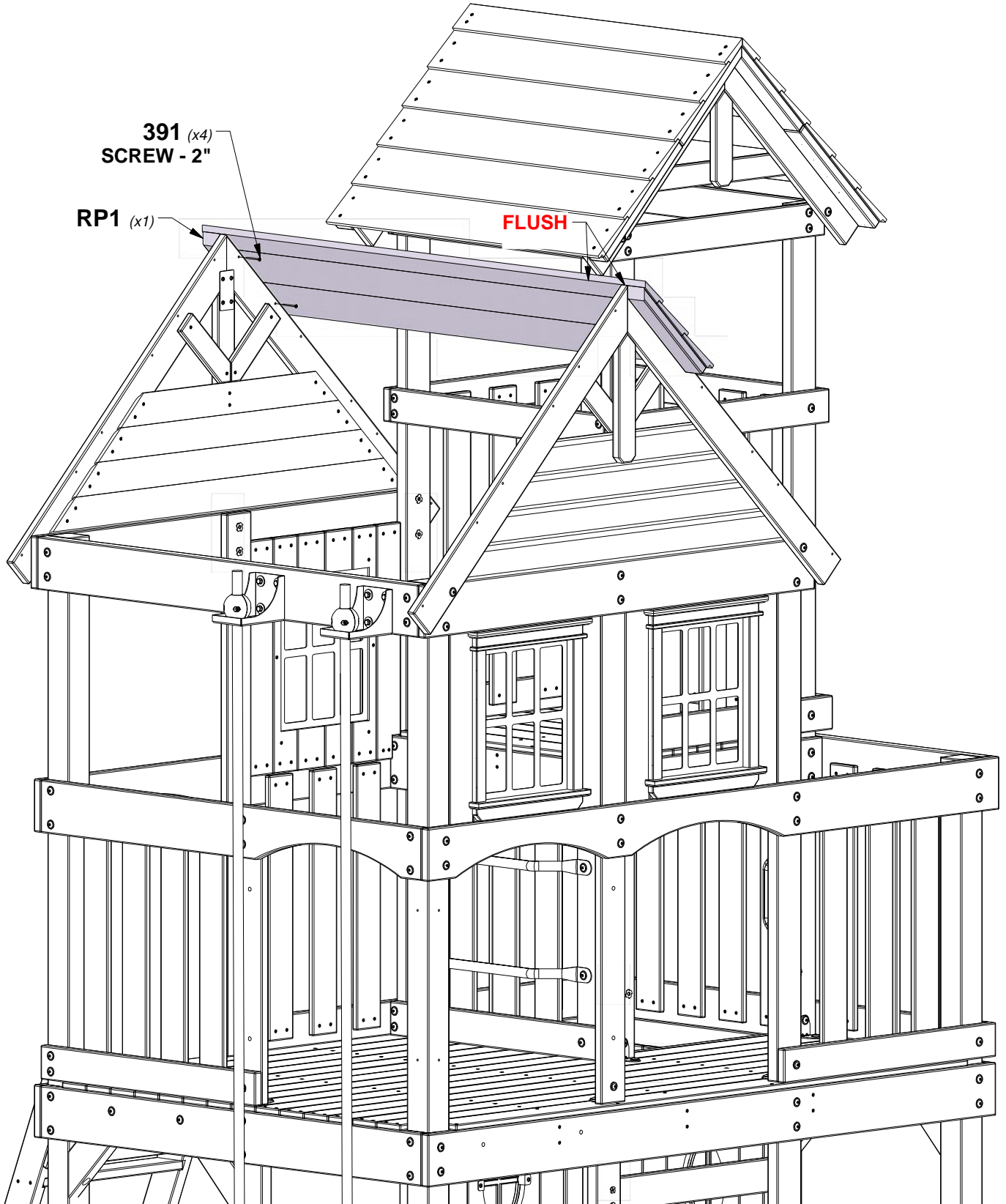

# STEP 74 - FORT ASSEMBLY

QTY	PART NUMBER	DESCRIPTION
4	H100391	SCREW PFH 8x2 BLK

.	.
.	.
.	.
.	.
.	.

**RP2 ROOF PANEL - W2A03757**  
 (x1) 1 5/8"x15 5/8"x59" (42x396x1586)

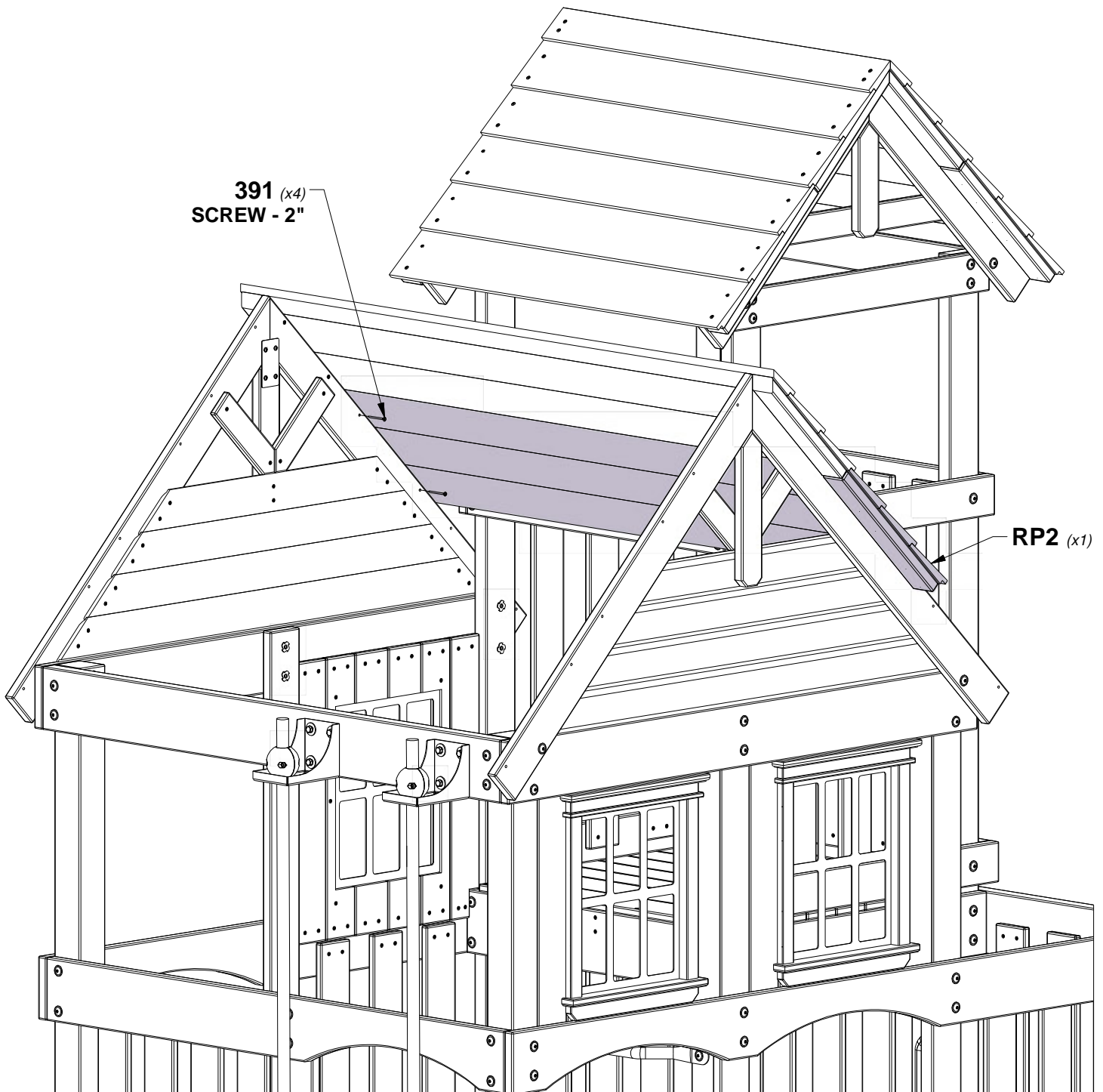



# STEP 75 - FORT ASSEMBLY

QTY	PART NUMBER	DESCRIPTION
2	H100387	SCREW PFH 8x1-1/4 BLK
4	H100391	SCREW PFH 8x2 BLK

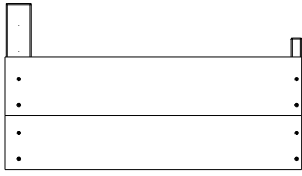

**RP3 ROOF PANEL - W2A03758**  
(x1) 1 5/8"x15 1/2"x27 3/4" (42x395x707)

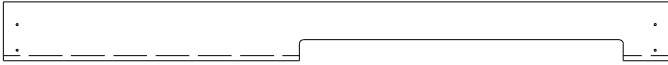

**R01 ROOF BOARD - W4L17916**  
(x1) 3/4"x5 1/2"x62 1/2" (18x140x1586)

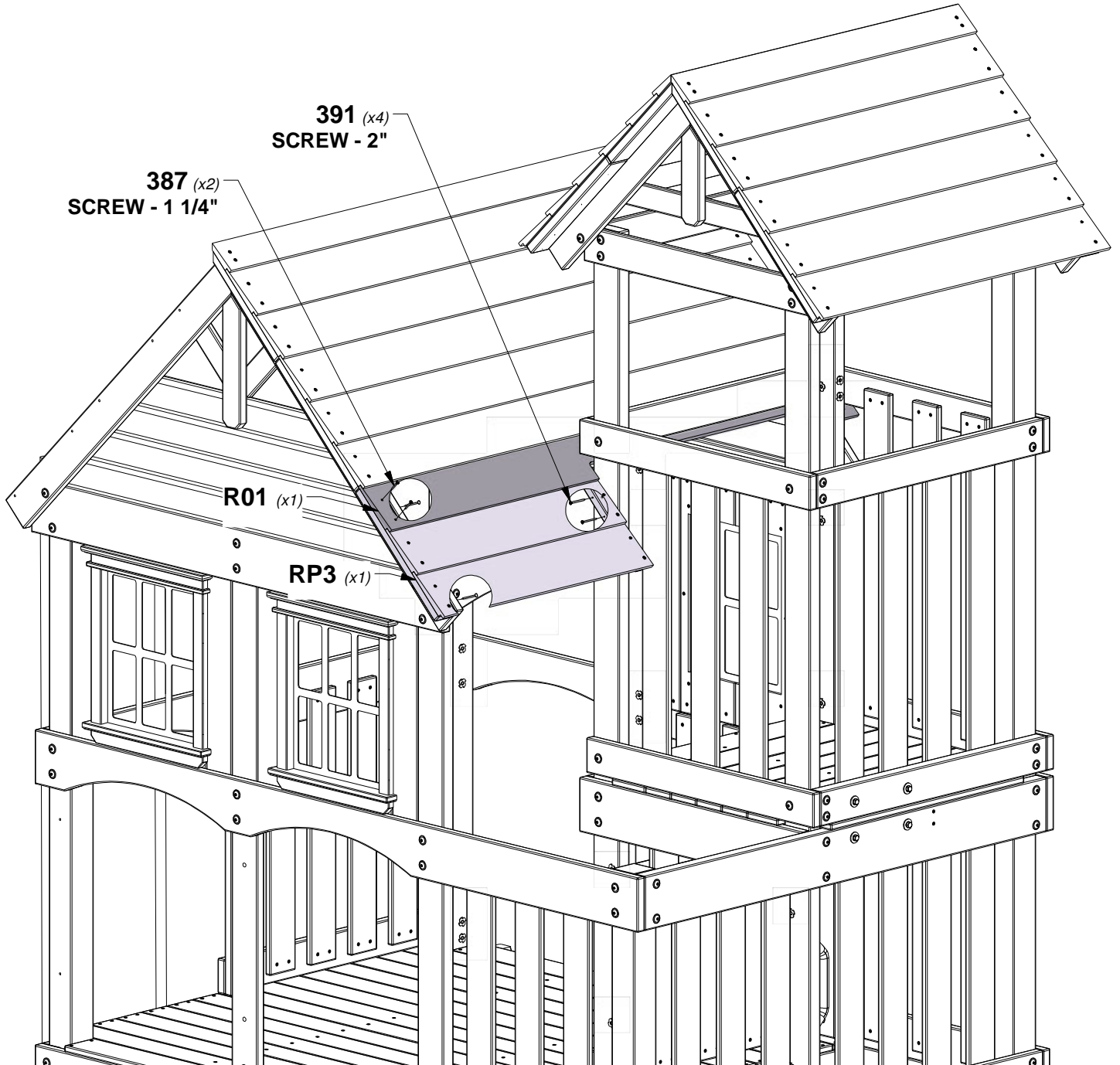

# STEP 76 - FORT ASSEMBLY

QTY	PART NUMBER	DESCRIPTION
2	H100387	SCREW PFH 8x1-1/4 BLK
2	H100391	SCREW PFH 8x2 BLK

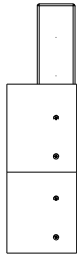

**RP4 ROOF PANEL - W2A03759**  
 (x1) 1 5/8"x15 1/2"x27 3/4" (42x395x111)

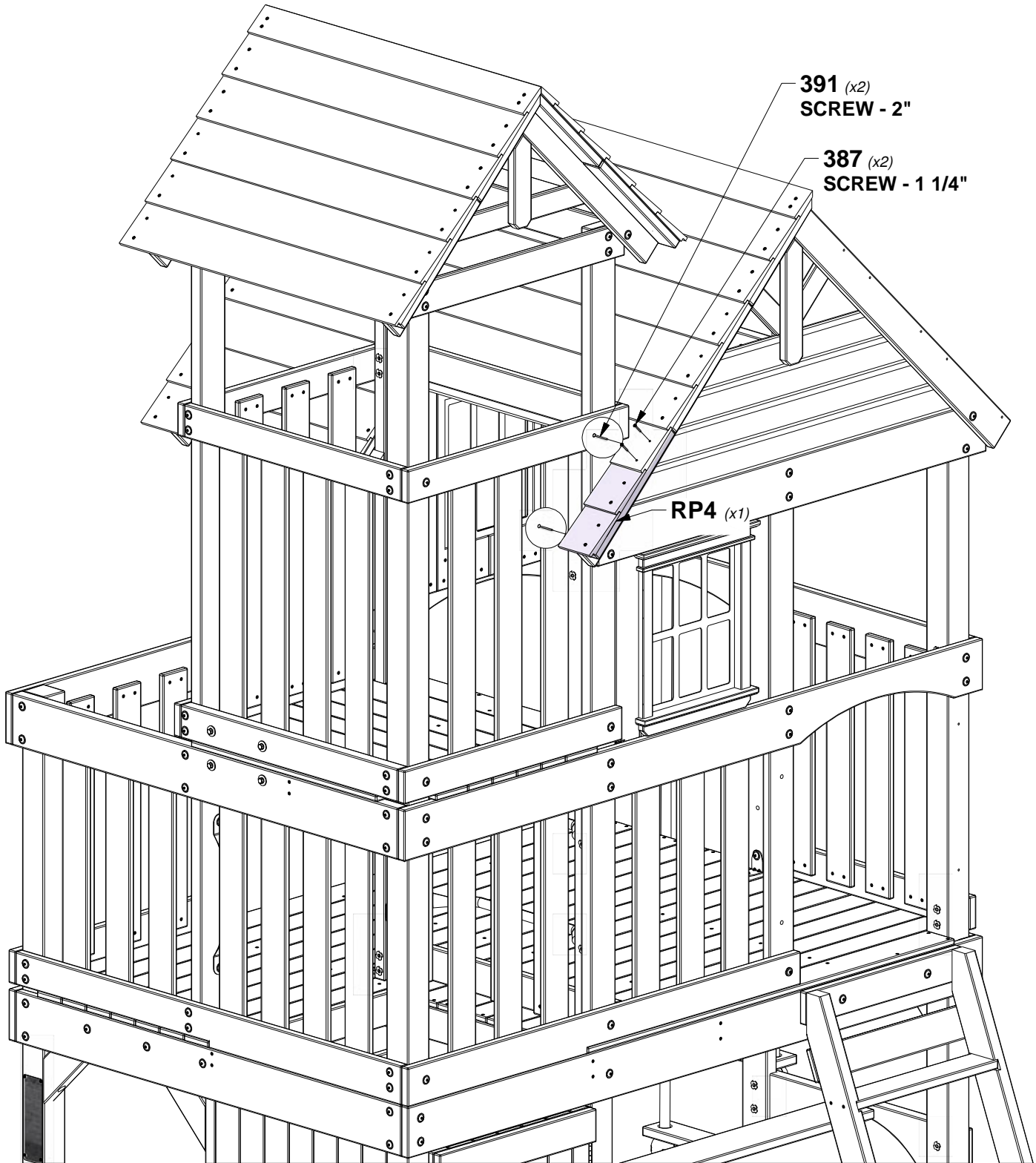

# STEP 77 - FORT ASSEMBLY

QTY	PART NUMBER	DESCRIPTION
12	H100380	SCREW PFH 8x1-1/8 BLK

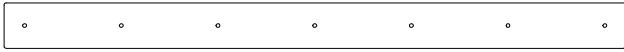

**N01 ROOF CLEAT - W4L17922**  
(x1) 5/8"x2 3/8"x32 3/8" (16x60x822)

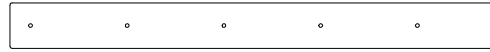

**N02 ROOF CLEAT - W4L17923**  
(x1) 5/8"x2 3/8"x25 3/8" (16x60x644)

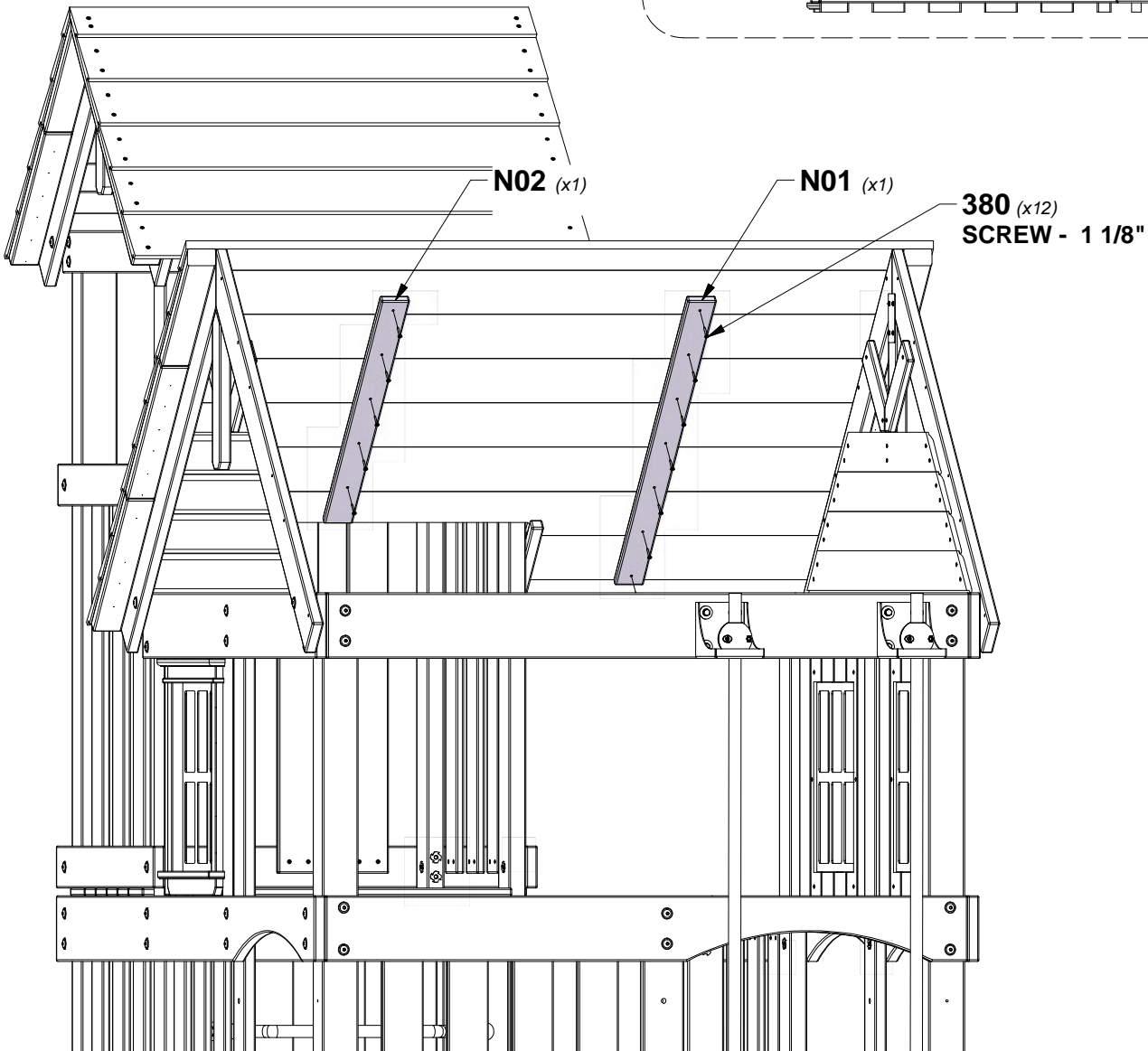
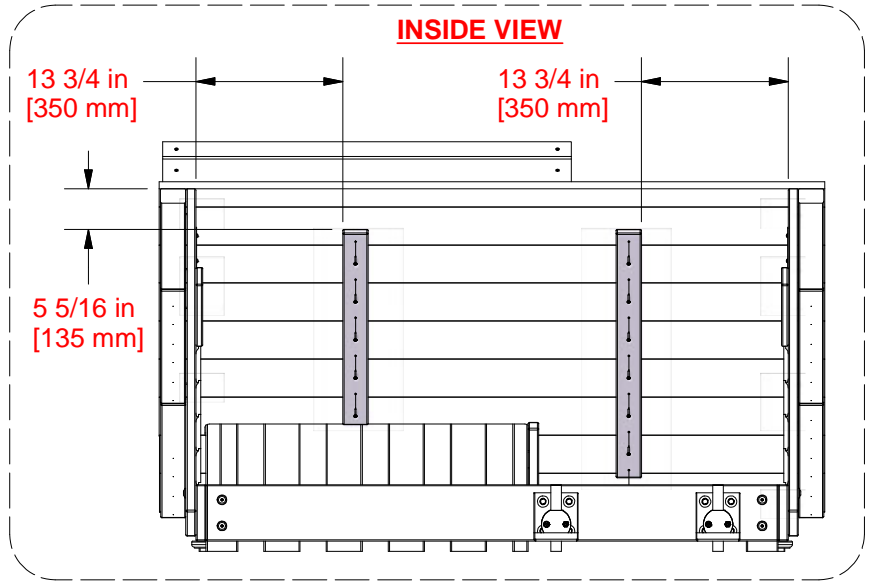

# STEP 78 - FORT ASSEMBLY

QTY	PART NUMBER	DESCRIPTION
4	H100391	SCREW PFH 8x2 BLK

:	:
:	:
:	:
:	:
:	:

**RP1 PEAK ROOF PANEL - W2A03756**  
(x1) 1 5/8"x13 3/8"x62 1/2" (42x341x1586)

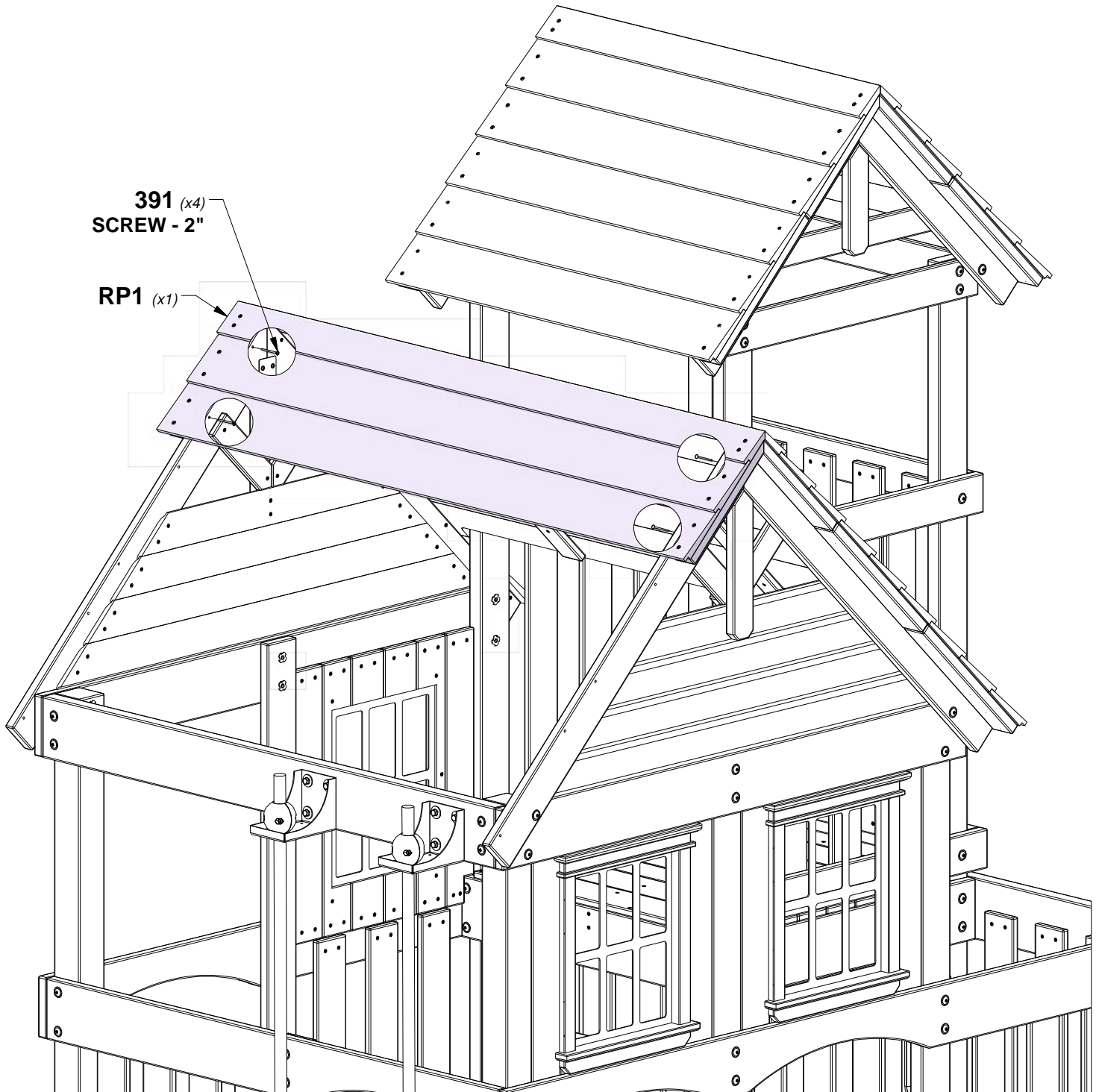

# STEP 79 - FORT ASSEMBLY

QTY	PART NUMBER	DESCRIPTION
4	H100391	SCREW PFH 8x2 BLK

.	.
.	.
.	.
.	.
.	.

**RP2 ROOF PANEL - W2A03757**  
(x1) 1 5/8"x15 5/8"x59" (42x396x1586)

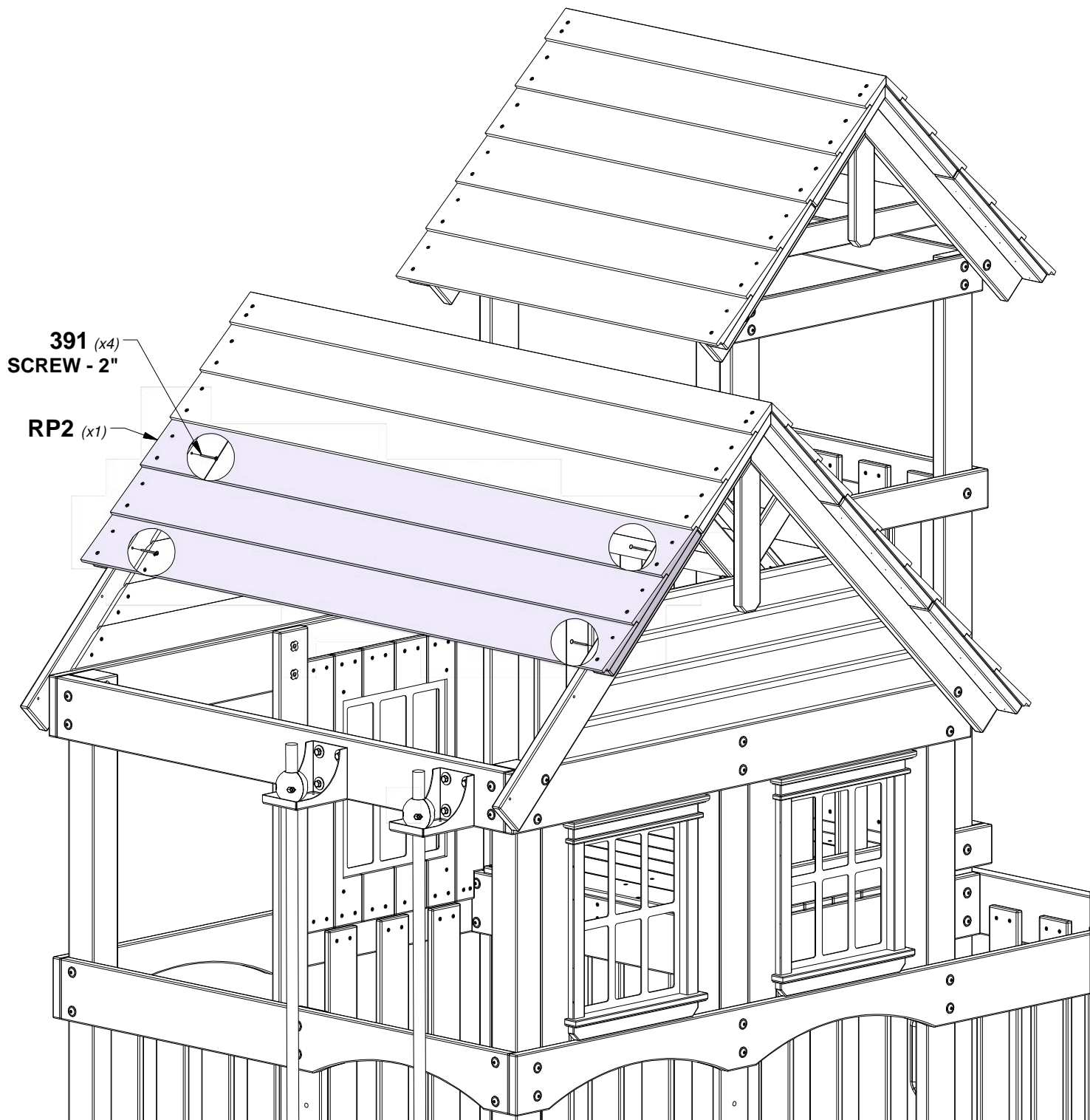

# STEP 80 - FORT ASSEMBLY

QTY	PART NUMBER	DESCRIPTION
4	H100387	SCREW PFH 8x1 1/4 BLK
4	H100391	SCREW PFH 8x2 BLK

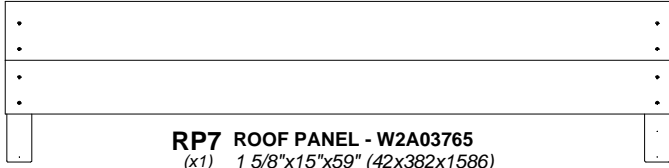

**RP7 ROOF PANEL - W2A03765**  
(x1) 1 5/8"x15"x59" (42x382x1586)



**R02 ROOF BOARD - W4L17917**  
(x1) 3/4"x5 1/2"x62 1/2" (18x140x1586)

**TIP:**  
**INSTALL RP7 ROOF PANEL FIRST.**

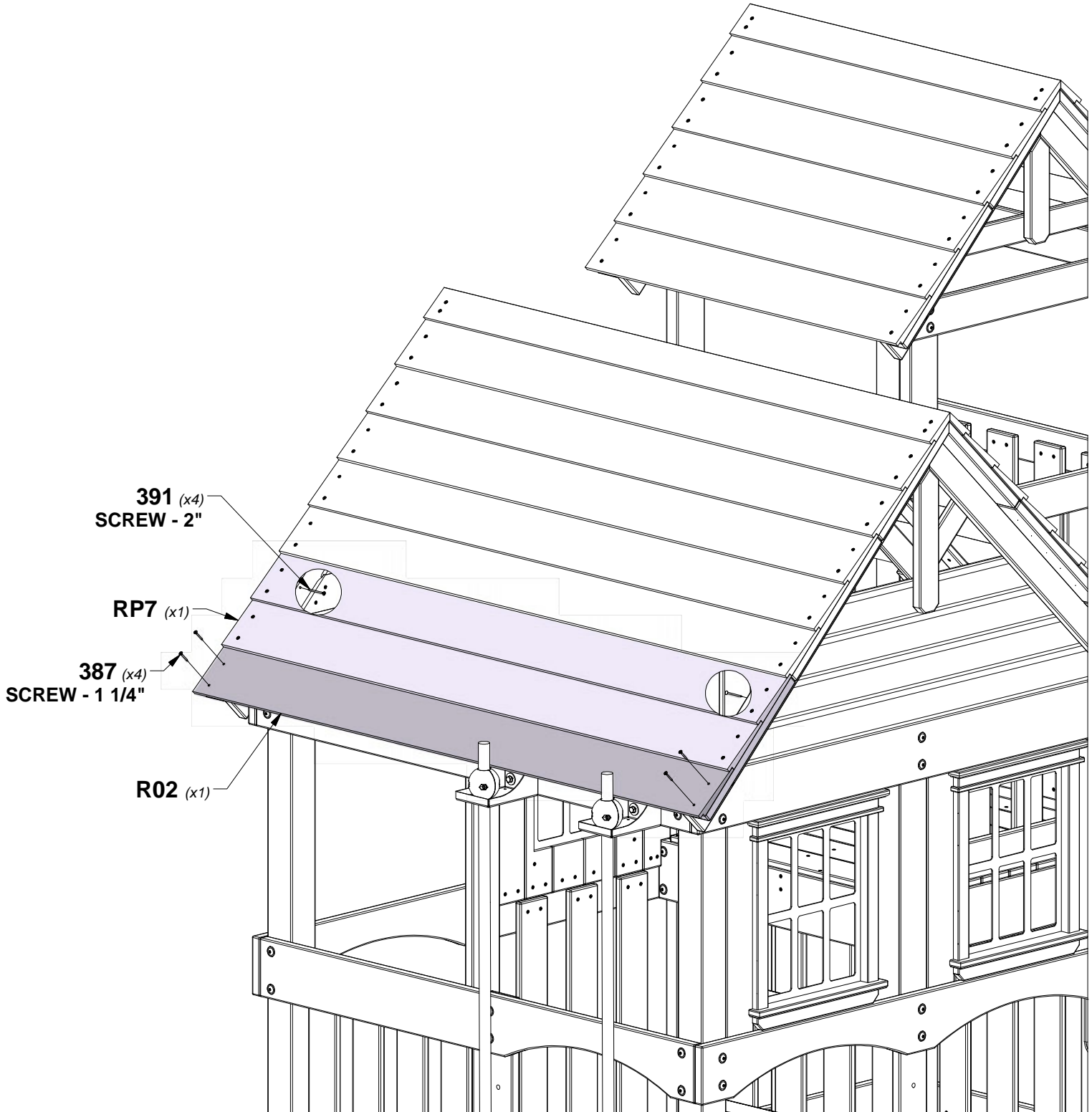



# STEP 81 - FORT ASSEMBLY

QTY	PART NUMBER	DESCRIPTION
14	H100380	SCREW PFH 8x1-1/8 BLK

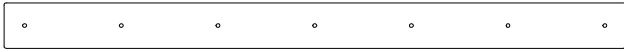

**N01 ROOF CLEAT - W4L17922**  
(x2) 5/8"x2 3/8"x32 3/8" (16x60x822)

## INSIDE VIEW

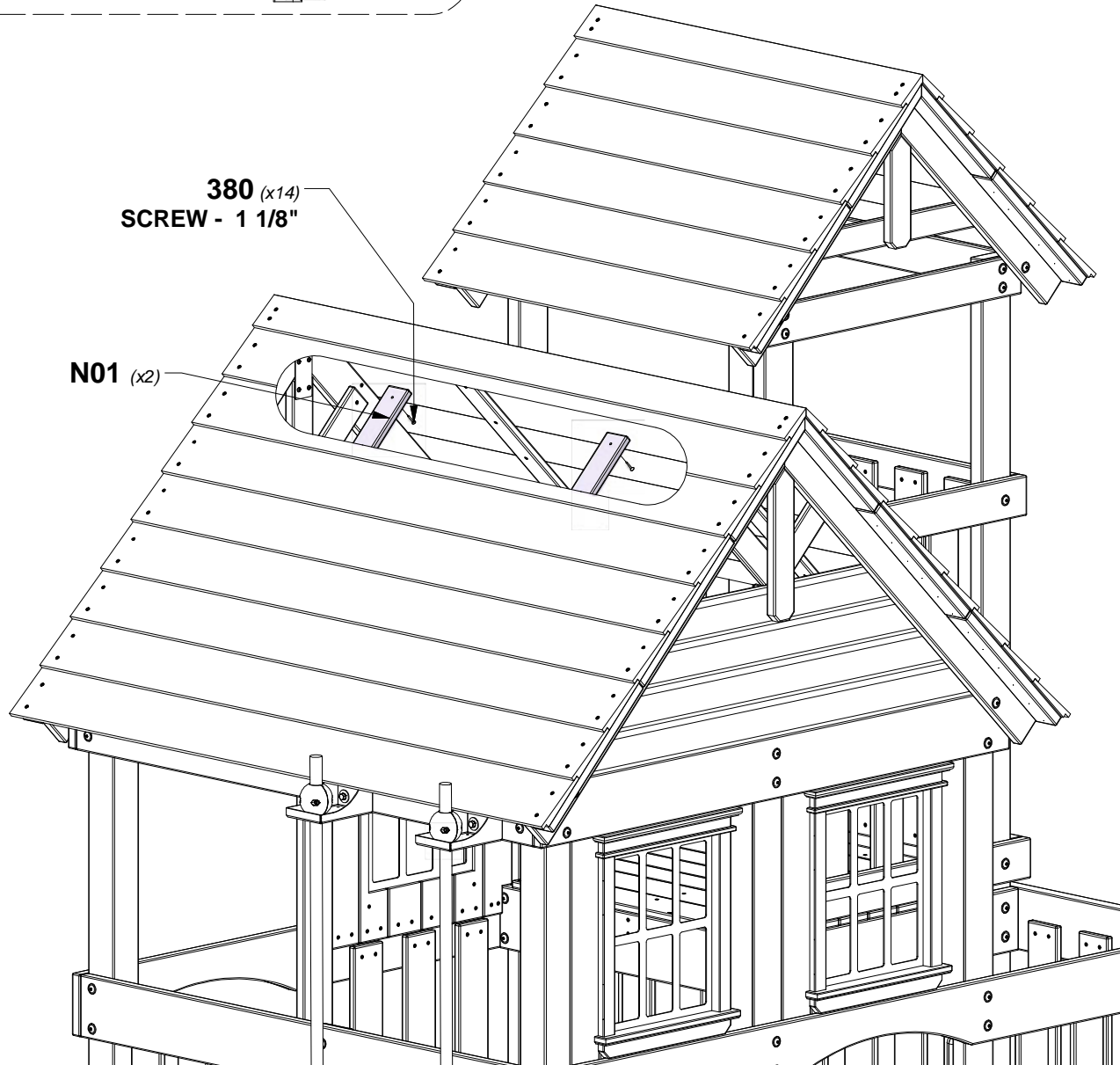
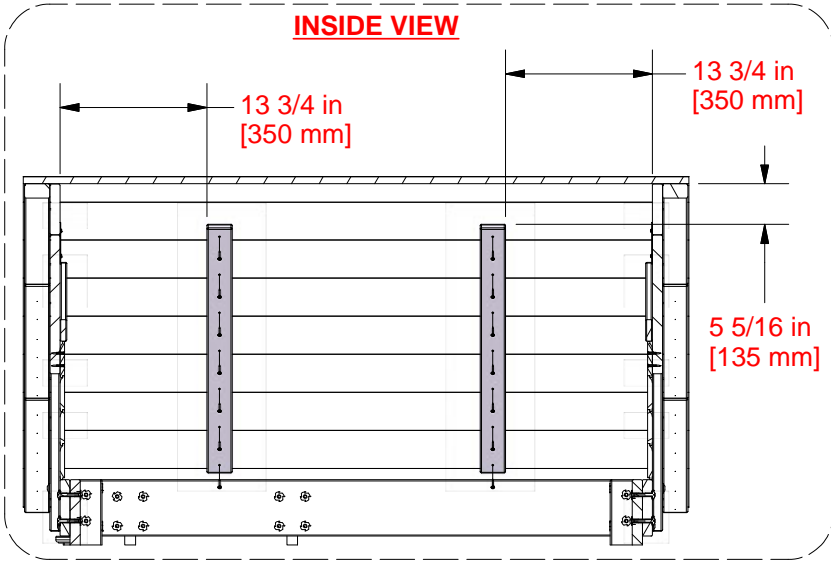

# STEP 82 - FORT ASSEMBLY

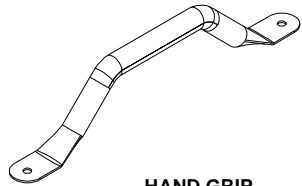

**A4M02249** HAND GRIP  
(x2) METAL GREY 381  
c/c

QTY	PART NUMBER	DESCRIPTION
2	H100379	T-NUT 5/16 BLK
2	H100468	BOLT WH 5/16x1 BLK
2	H100471	LAG SCREW WH 5/16x1-1/2 BLK

**TIP:**  
**INSTALL T-NUTS IN WOOD FIRST**

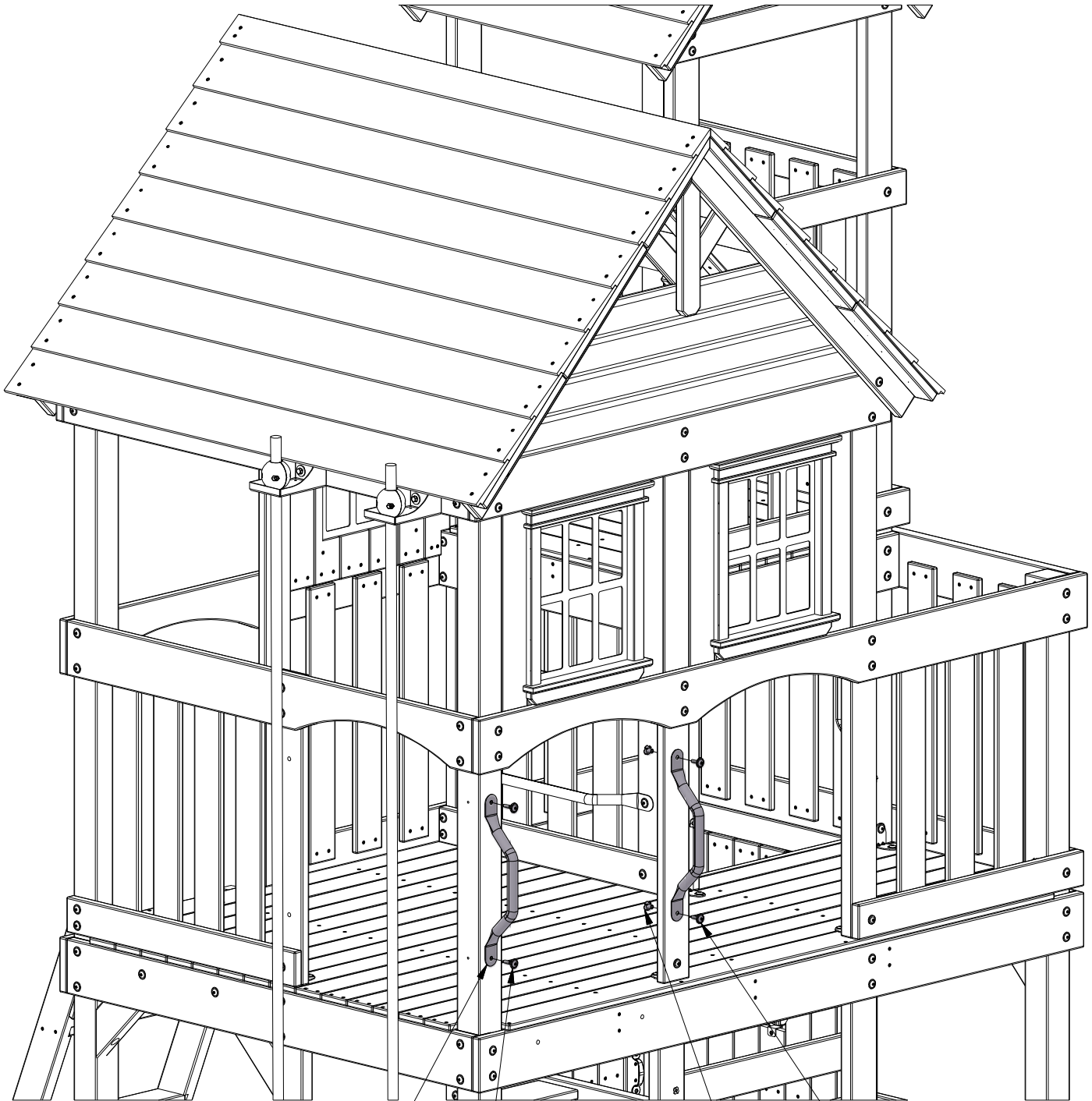

**249** (x2)  
HAND GRIP METAL GREY 381 c/c

**471** (x2)  
LAG SCREW - 1 1/2"

**468** (x2)  
BOLT - 1"

**379** (x2)  
T-NUT - 5/16"



# STEP 83 - FORT ASSEMBLY

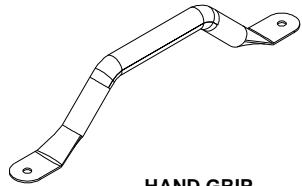

**A4M02249** HAND GRIP  
(x2) METAL GREY 381  
c/c

QTY	PART NUMBER	DESCRIPTION
2	H100379	T-NUT 5/16 BLK
2	H100468	BOLT WH 5/16x1 BLK
2	H100471	LAG SCREW WH 5/16x1-1/2 BLK

**TIP:**  
**INSTALL T-NUTS IN WOOD FIRST**

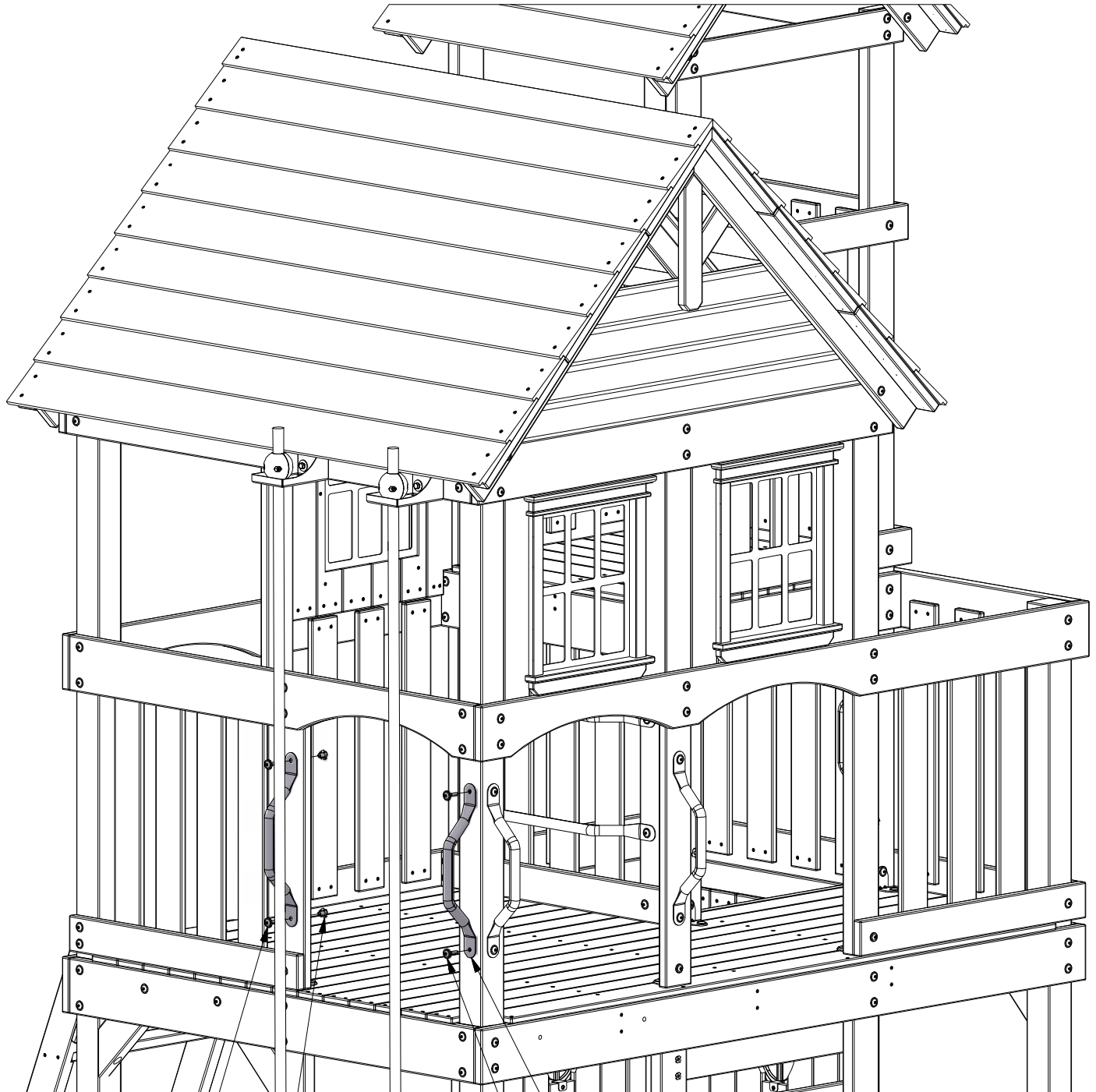

**468** (x2)  
BOLT - 1"

**379** (x2)  
T-NUT - 5/16"

**249** (x2)  
HAND GRIP METAL GREY 381 c/c

**471** (x2)  
LAG SCREW - 1 1/2"

# STEP 84 - FORT ASSEMBLY

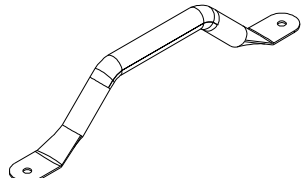

**A4M02249** HAND GRIP  
(x2) METAL GREY 381  
c/c

QTY	PART NUMBER	DESCRIPTION
2	H100379	T-NUT 5/16 BLK
2	H100468	BOLT WH 5/16x1 BLK
2	H100471	LAG SCREW WH 5/16x1-1/2 BLK

**TIP:**  
**INSTALL T-NUTS IN WOOD FIRST**

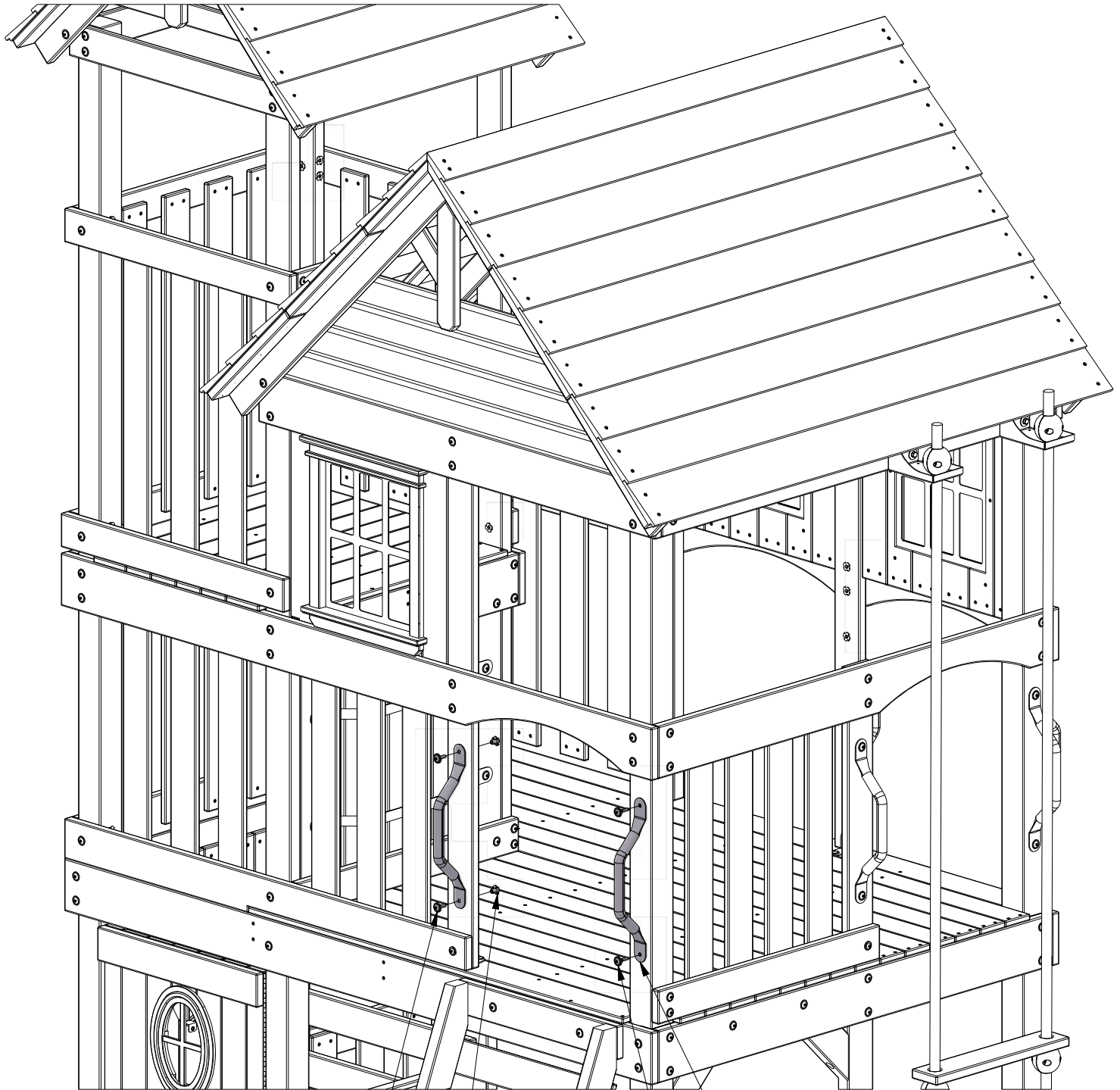

**468** (x2)  
**BOLT - 1"**

**379** (x2)  
**T-NUT - 5/16"**

**249** (x2)  
**HAND GRIP METAL GREY 381 c/c**

**471** (x2)  
**LAG SCREW - 1 1/2"**

# STEP 85 - FORT ASSEMBLY

QTY	PART NUMBER	DESCRIPTION
2	H100198	WASHER LOCK EXT 8x19 BLK
2	H100457	BOLT WH 5/16x2 BLK

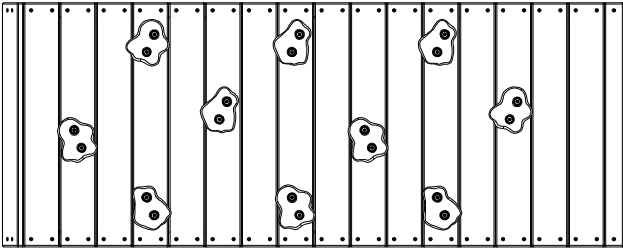

(x1) ROCKWALL ASSEMBLY

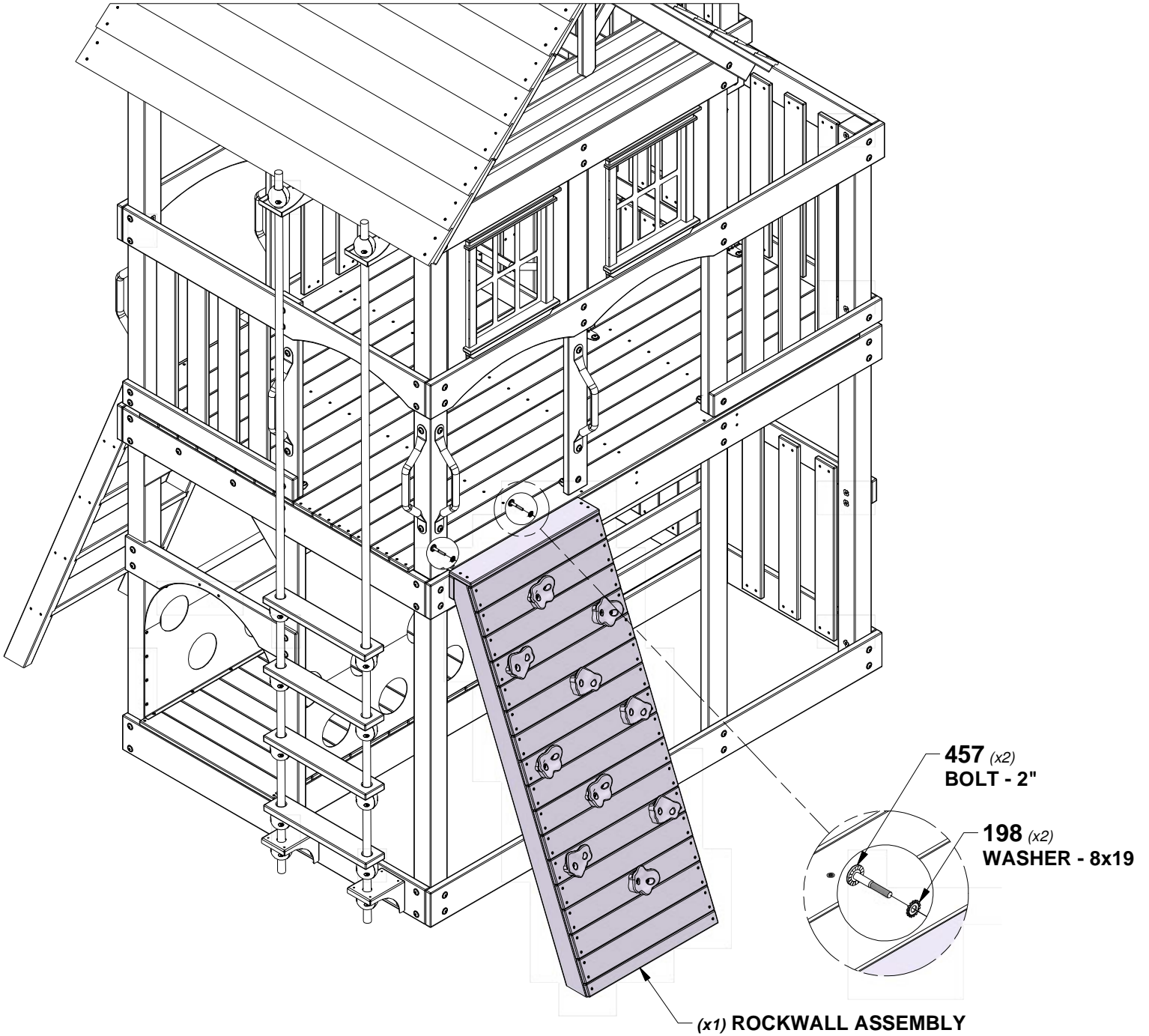

# STEP 86 - FORT ASSEMBLY

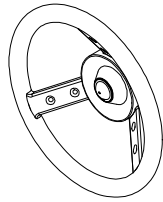

A6P00618 STEERING WHEEL  
(x1)

**TIP:**  
CENTER ON PICKET & DRILL (1) 1/4" [6 mm]  
HOLE THRU PICKET FOR HARDWARE.

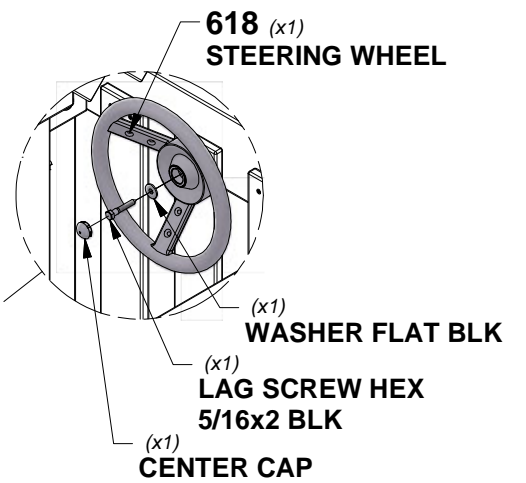
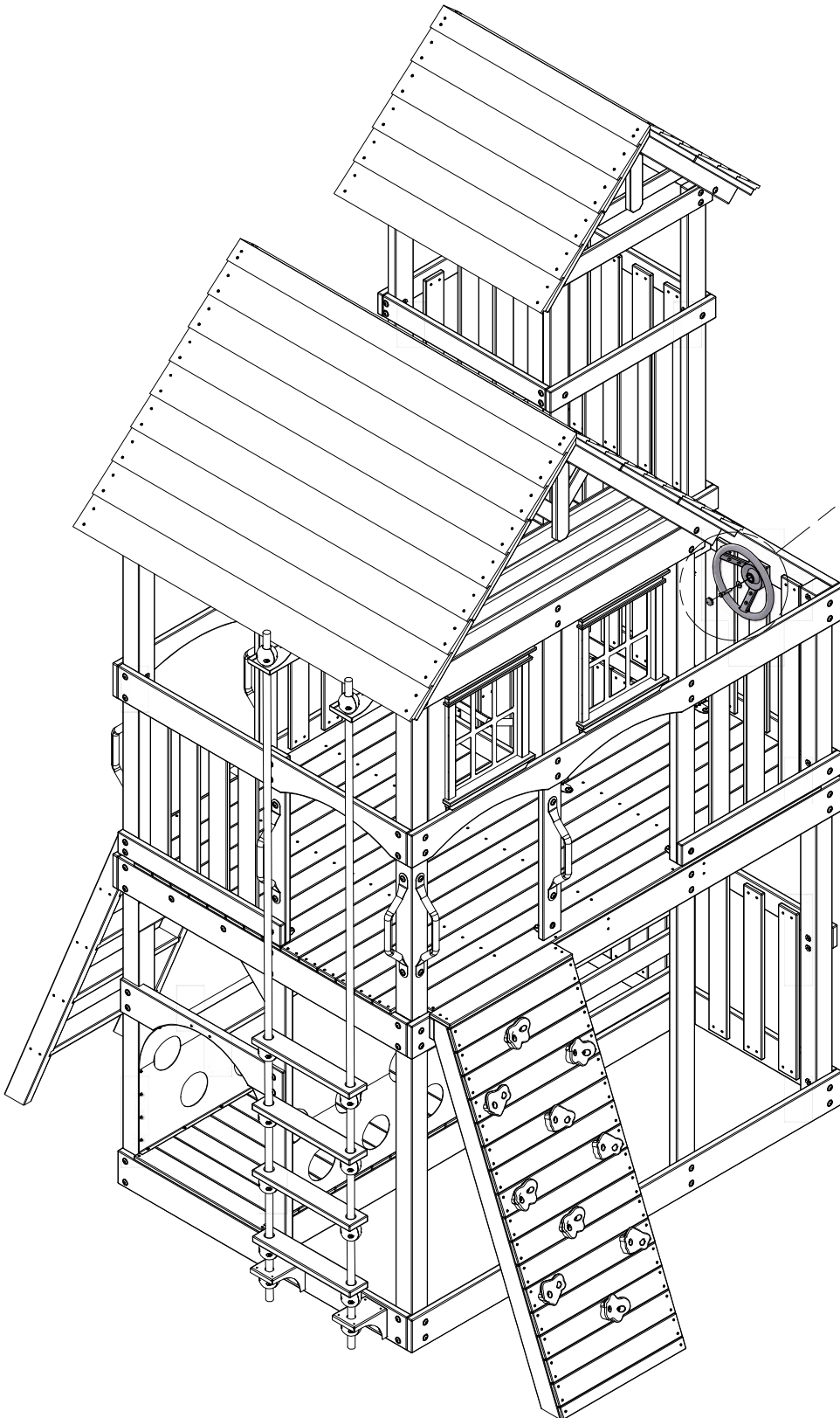

618 (x1)  
STEERING WHEEL

(x1)  
WASHER FLAT BLK

(x1)  
LAG SCREW HEX  
5/16x2 BLK

(x1)  
CENTER CAP

**INCLUDED WITH STEERING WHEEL**

# STEP 87 - FORT ASSEMBLY

QTY	PART NUMBER	DESCRIPTION
2	H100387	SCREW PFH 8x1-1/4 BLK

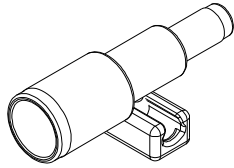

**A6P00596**  
*(x1)* TELESCOPE

**TIP:**  
PILOT DRILL, IN DESIRED LOCATION, USING A  
1/8" (3 mm) DRILL BIT.

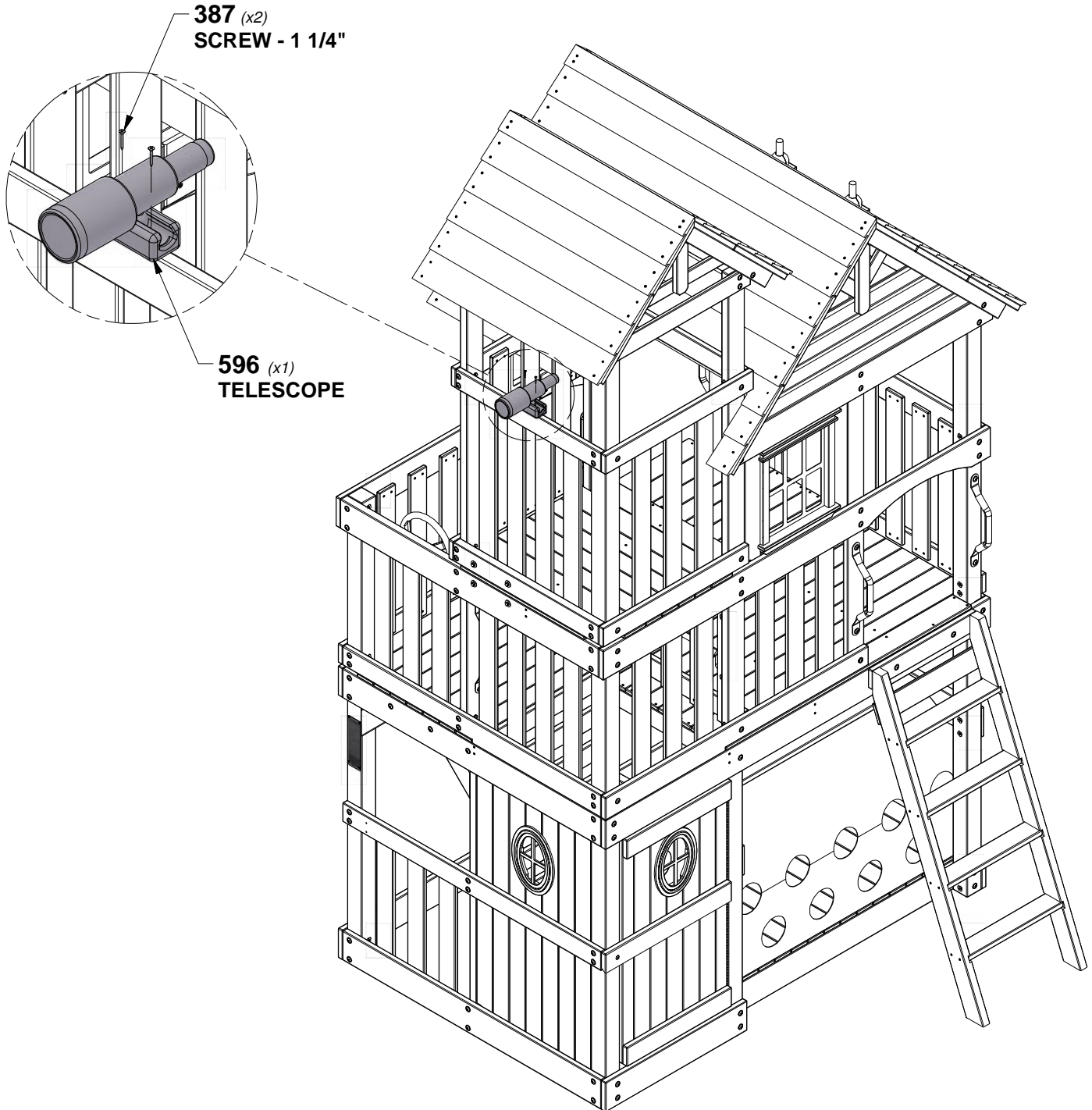



# STEP 88 - FORT ASSEMBLY

QTY	PART NUMBER	DESCRIPTION
4	H100201	SCREW PFH 8x2-1/2 BLK



**H18 TABLE SUPPORT - W4L17980**  
(x1) 1"x2 3/4"x10 1/2" (24x70x268)



**H19 TABLE SUPPORT - W4L17981**  
(x1) 1"x2 3/4"x10 1/2" (24x70x268)

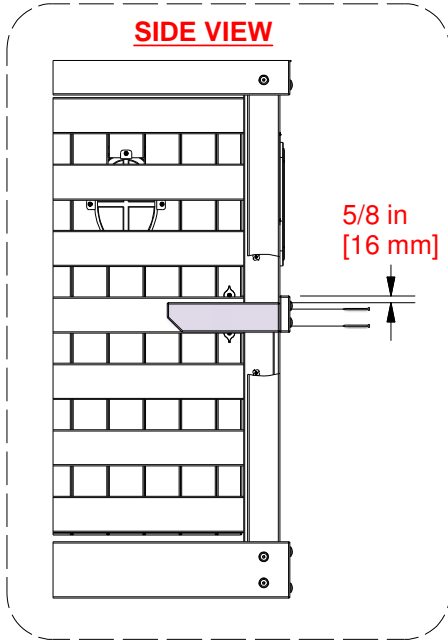
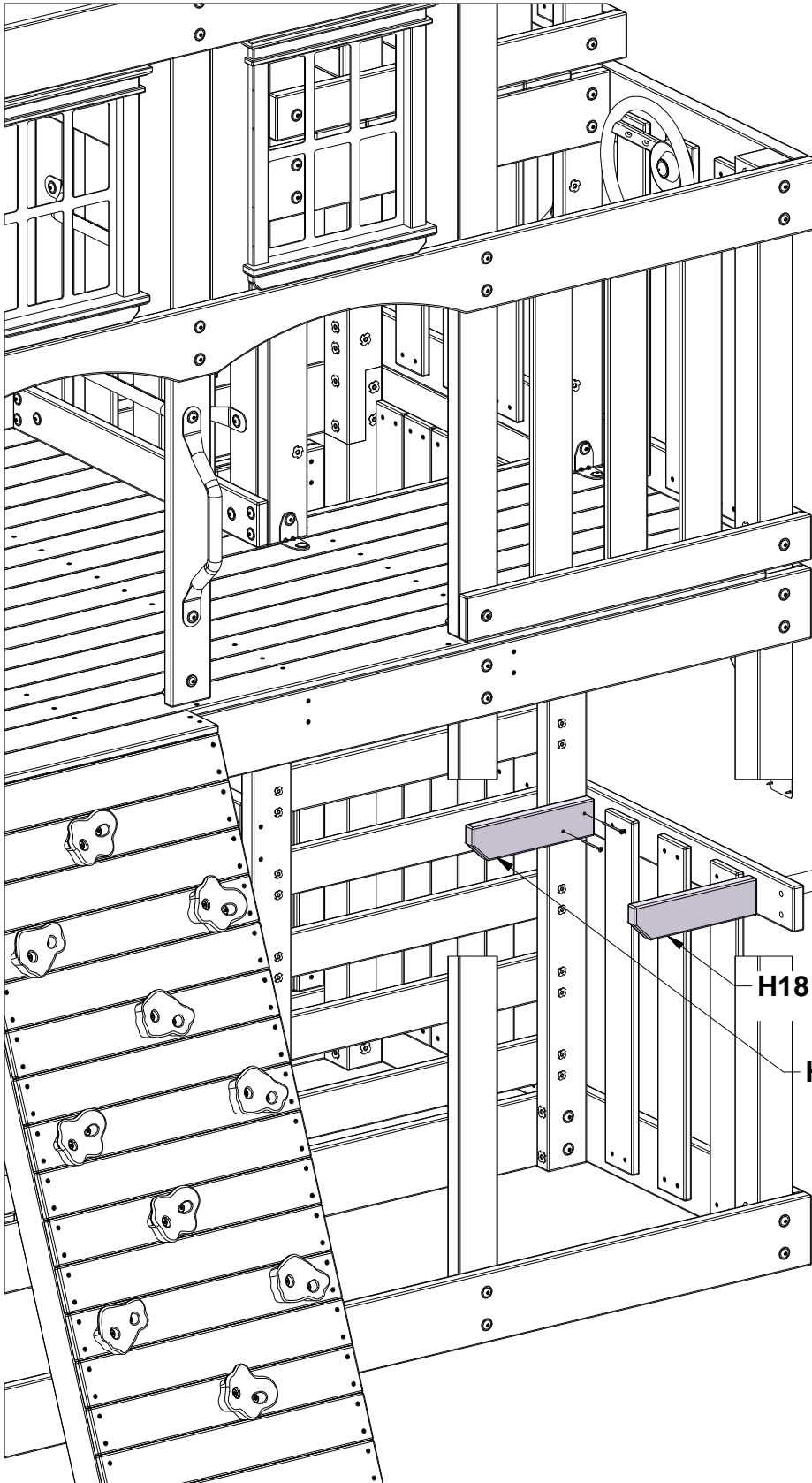

**201 (x4)**  
**SCREW - 2 1/2"**

**H18 (x1)**

**H19 (x1)**

# STEP 89 - FORT ASSEMBLY

QTY	PART NUMBER	DESCRIPTION
8	H100087	SCREW PFH 8x1-1/4"



**K02 TABLE TOP - W4L17982**  
(x1) 5/8"x5 1/4"x22 3/8" (16x134x568)



**K03 TABLE TOP - W4L17983**  
(x1) 5/8"x5 1/4"x22 3/8" (16x134x568)

**TIP:**  
CENTER PILOT HOLES OVER  
SUPPORT BOARDS.

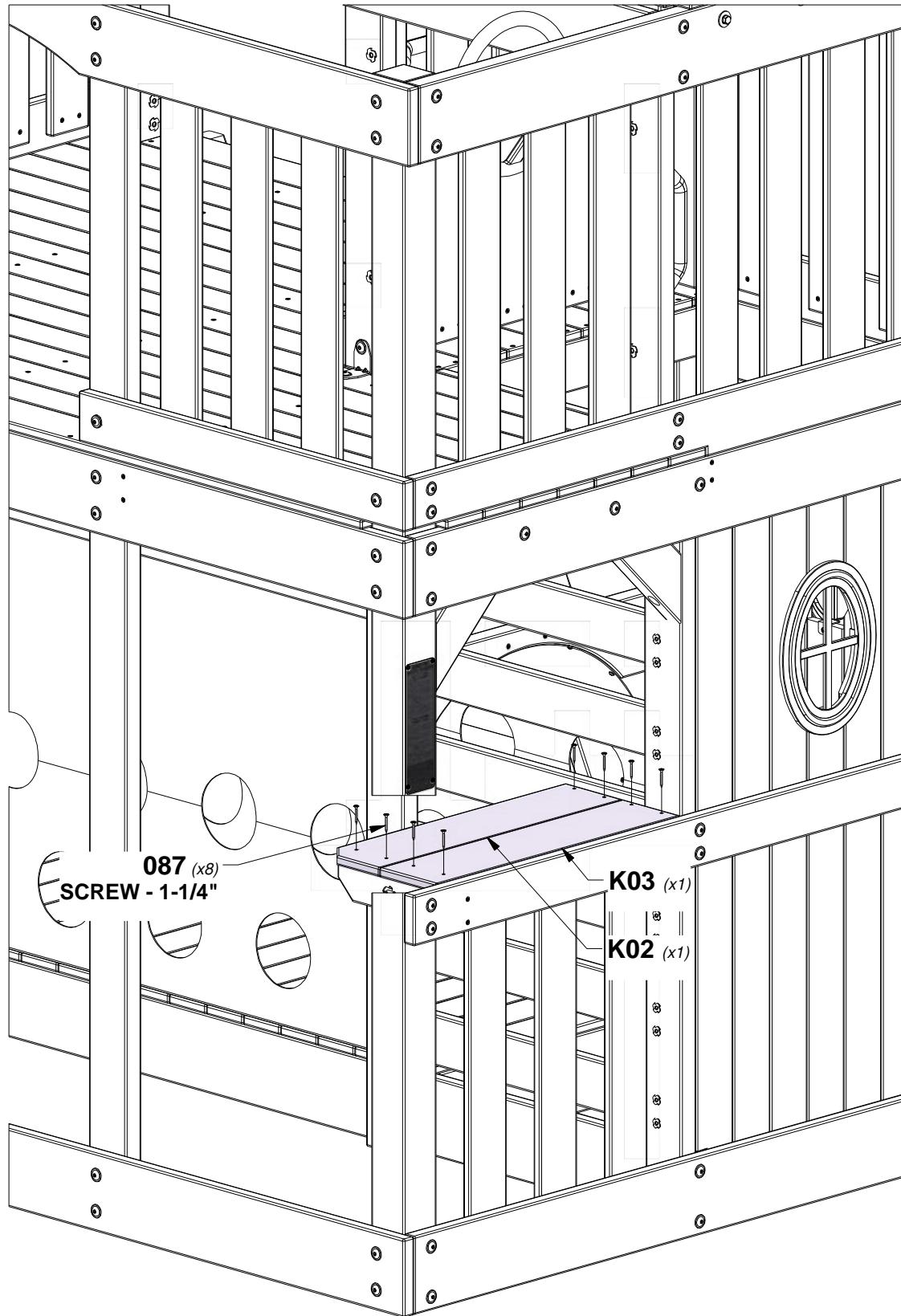

# STEP 90 - FORT ASSEMBLY

QTY	PART NUMBER	DESCRIPTION
4	H100128	SCREW PWH 8x5/8

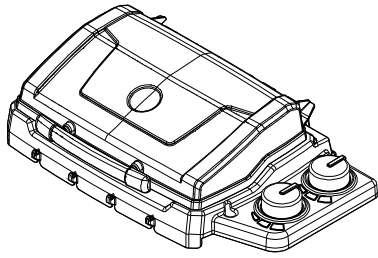

**A6P00282 BBQ GRILL**  
(x1)

**NOTE:**  
CENTER GRILL ON TABLE TOP.

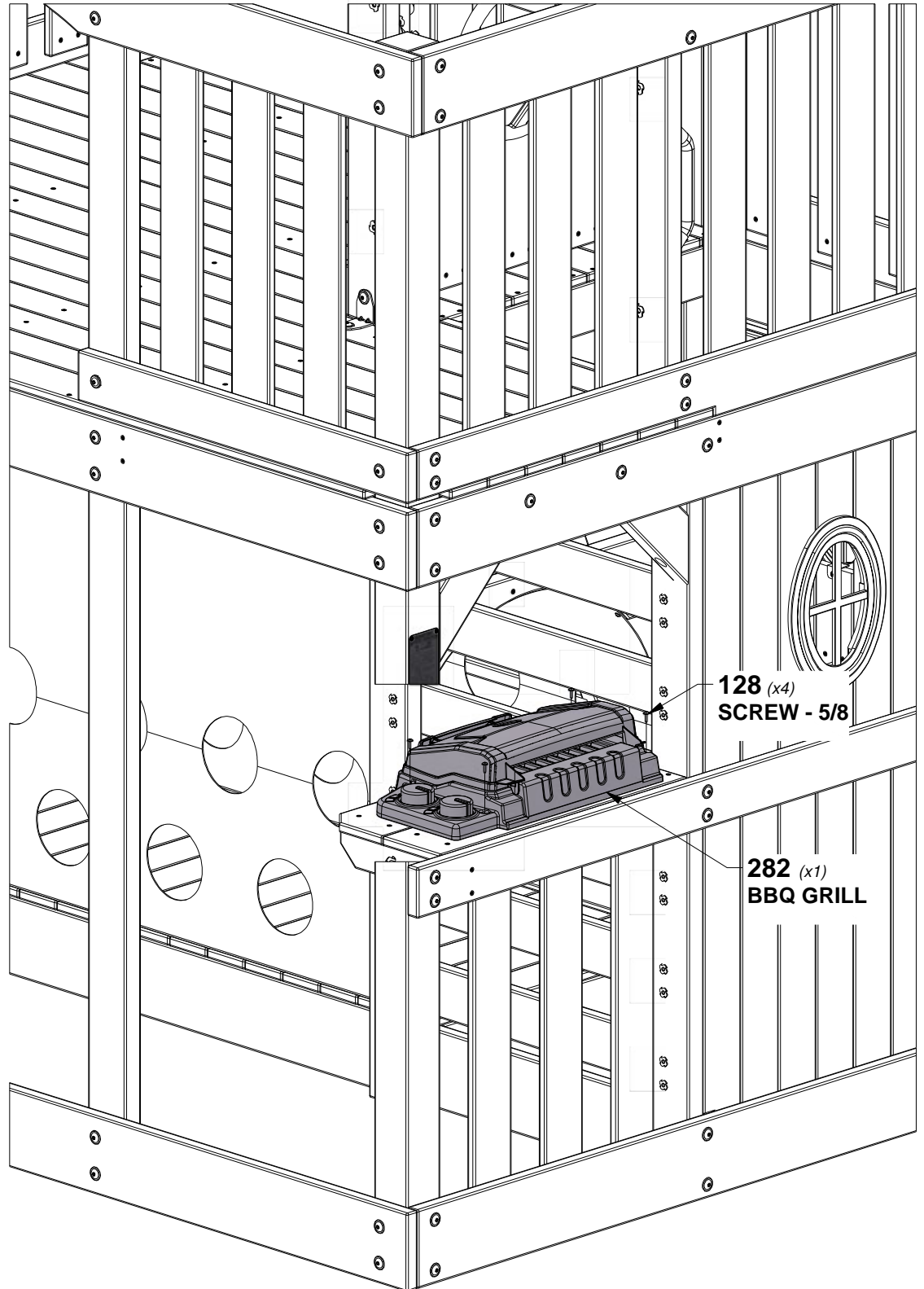

**128 (x4)**  
**SCREW - 5/8**

**282 (x1)**  
**BBQ GRILL**



# STEP 91 - FORT ASSEMBLY

QTY	PART NUMBER	DESCRIPTION
2	H100379	T-NUT 5/16 BLK
2	H100468	BOLT WH 5/16x1 BLK

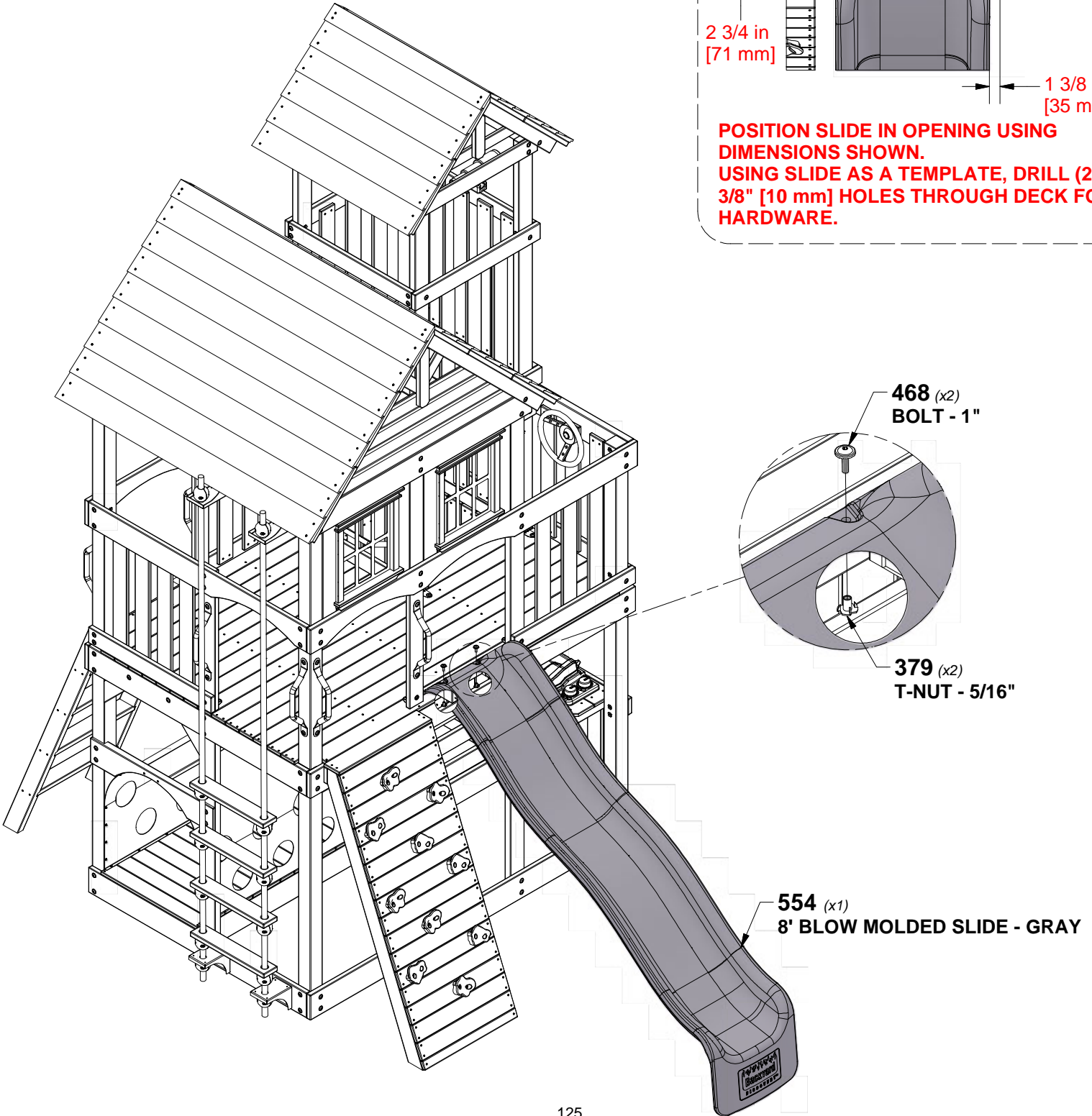
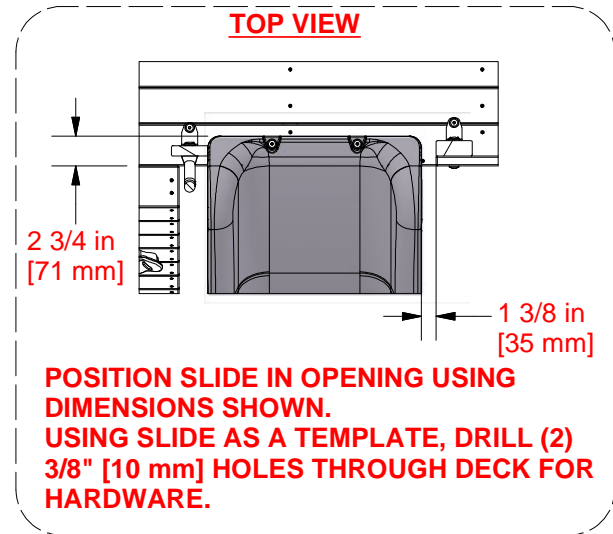
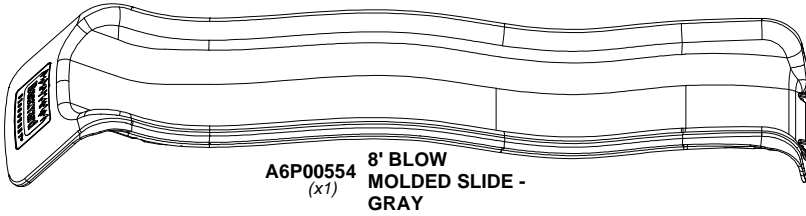

# STEP 92 - FORT ASSEMBLY

QTY	PART NUMBER	DESCRIPTION
4	H100477	WASHER SPLIT 5/16 BLK
4	H100478	WASHER FLAT 8x27 BLK
4	H100657	BOLT HEX 5/16x1-3/4 BLK

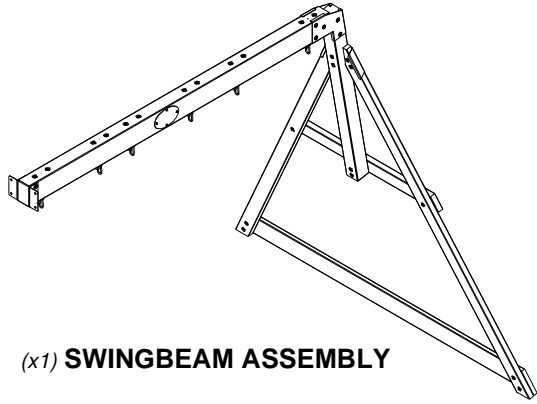

(x1) SWINGBEAM ASSEMBLY

**NOTE:**  
T-NUTS INSTALLED IN PREVIOUS STEPS.

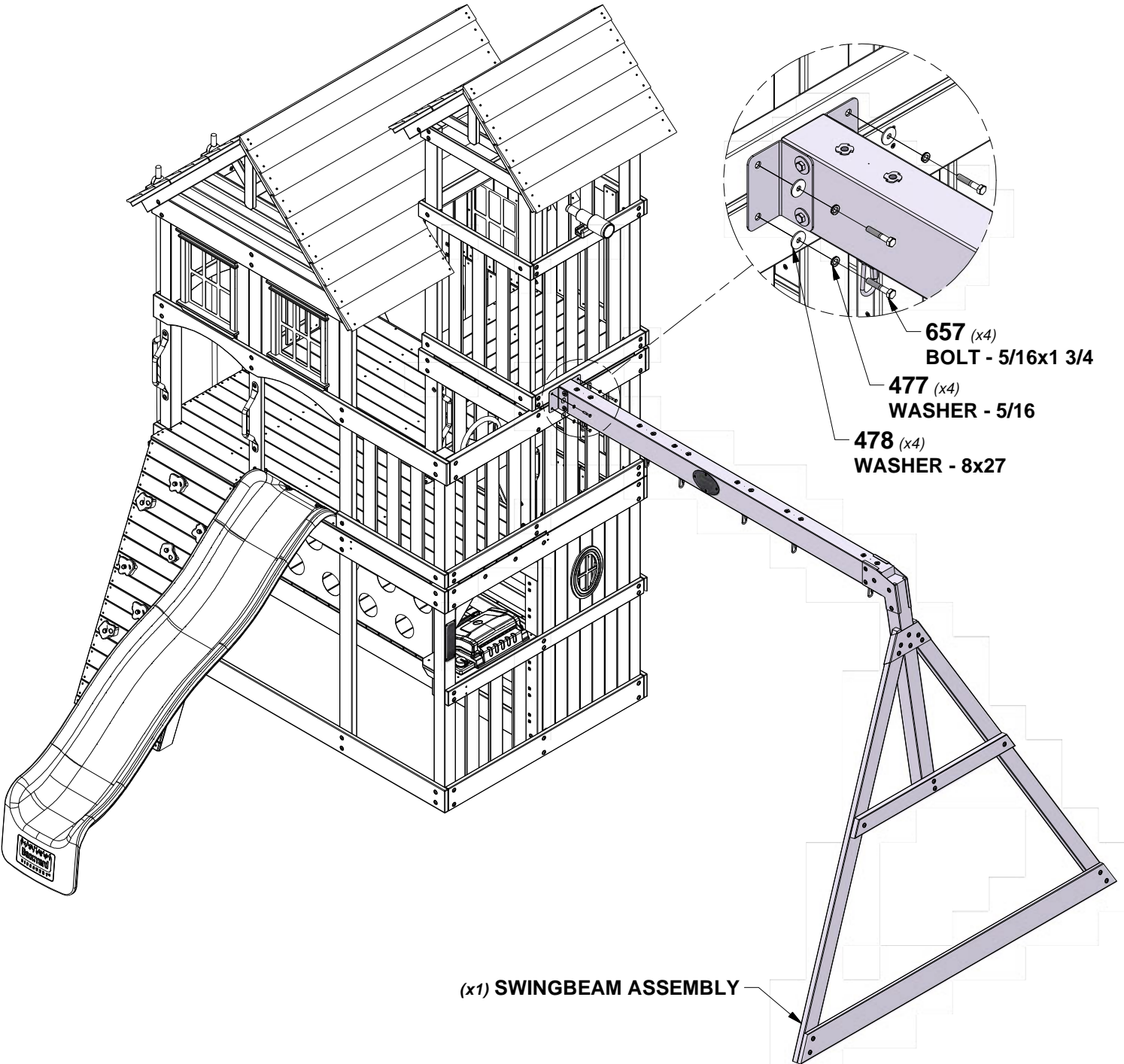

- 657 (x4)  
BOLT - 5/16x1 3/4
- 477 (x4)  
WASHER - 5/16
- 478 (x4)  
WASHER - 8x27

(x1) SWINGBEAM ASSEMBLY

# STEP 1 - WEB SWING ASSEMBLY

QTY	PART NUMBER	DESCRIPTION
4	H100831	NUT BARREL PTH BLK 1/4x3/4
4	H100832	BOLT PTH 1/4x3/4

**IMPORTANT: SLIDE ROPE LOOPS OVER TUBE ENDS FIRST!**

SLIDE NARROW END OF TUBES INTO LARGER OPENING AFTER SLIDING ROPE LOOPS ONTO TUBES.

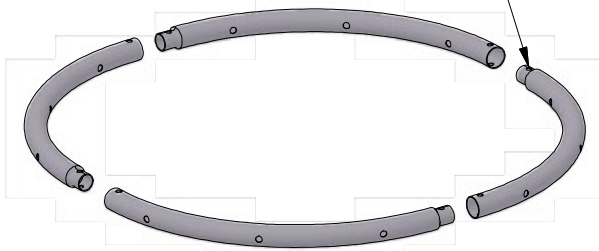

NOTE: ROPE WEBBING NOT SHOWN IN ILLUSTRATION FOR CLARITY.

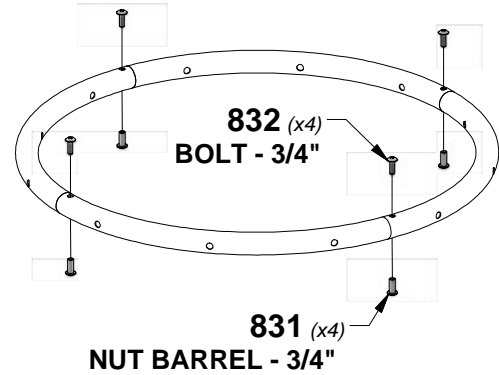

NOTE: IT IS IMPORTANT THAT THE WEB SWING HANG LEVEL.

TO ENSURE STRAIGHT SWINGING MOTION, ADJUST BOTH "S" BRACKETS UNTIL WEB SEAT IS LEVEL.

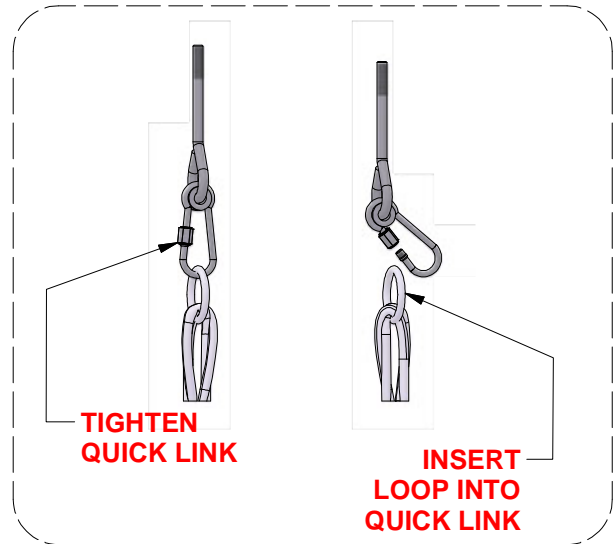

SWING MUST BE SET AT A MINIMUM OF 8 INCHES OFF THE GROUND WHEN INSTALLED.

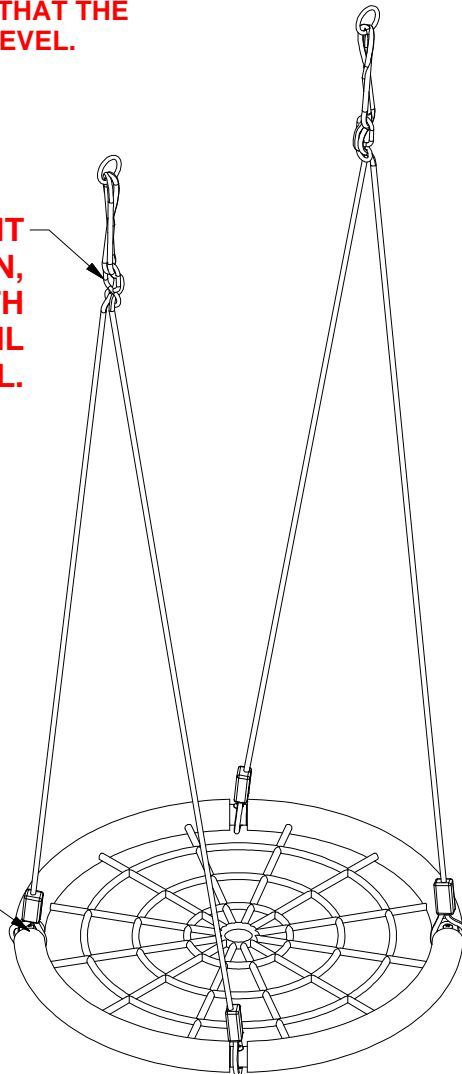

# STEP 93 - FORT ASSEMBLY



**A4M02212 CHAIN BLACK**  
(x4) 57"

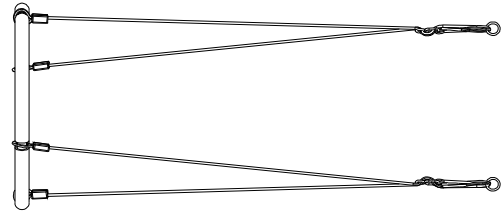

**A4M01126 26" WEB SWING**  
(x1)

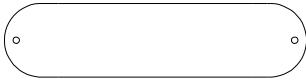

**A6P00595 SWING SEAT**  
(x2) GREY 22"



**A4M00633 QUICK LINK BLK**  
(x4)

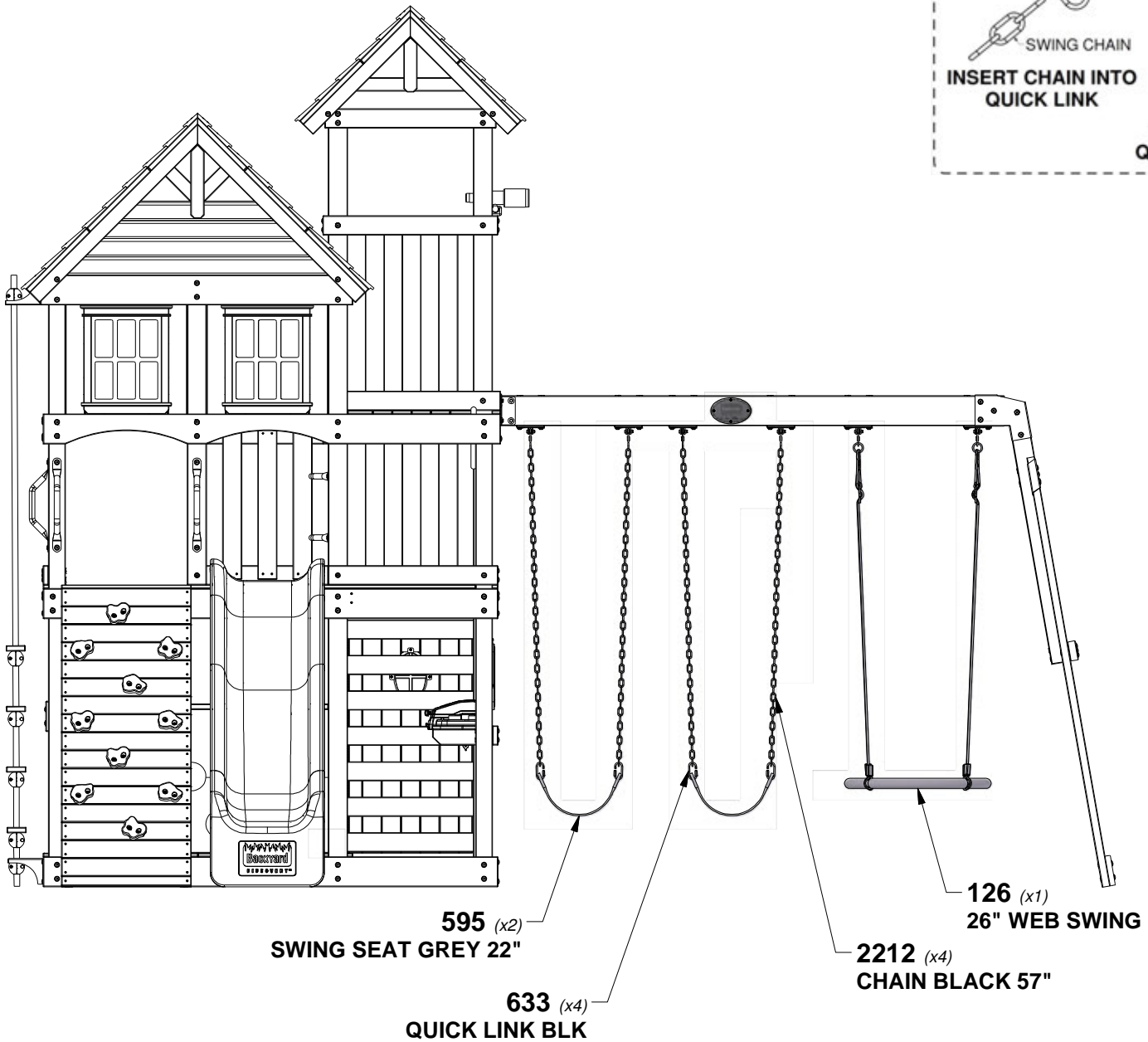
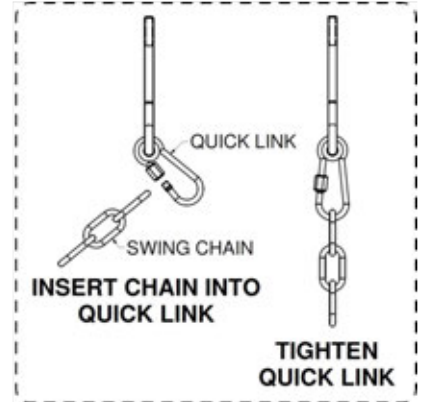

# STEP 94 - FORT ASSEMBLY

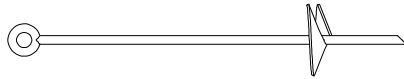

**A4M02252 AUGER GROUND STAKE**  
(x8)

QTY	PART NUMBER	DESCRIPTION
1	H100197	LAG SCREW WH 5/16x2-1/2 BLK
2	H100378	BOLT WH 5/16x1 3/4 BLK
7	H100379	T-NUT 5/16 BLK
5	H100459	BOLT WH 5/16x1 1/4 BLK

**NOTE:**  
TWIST GROUND STAKE INTO THE GROUND WHERE SHOWN. THEN USING GROUND STAKE AS A GUIDE, DRILL A 3/8" (10mm) HOLE FOR HARDWARE. (7 PLACES)

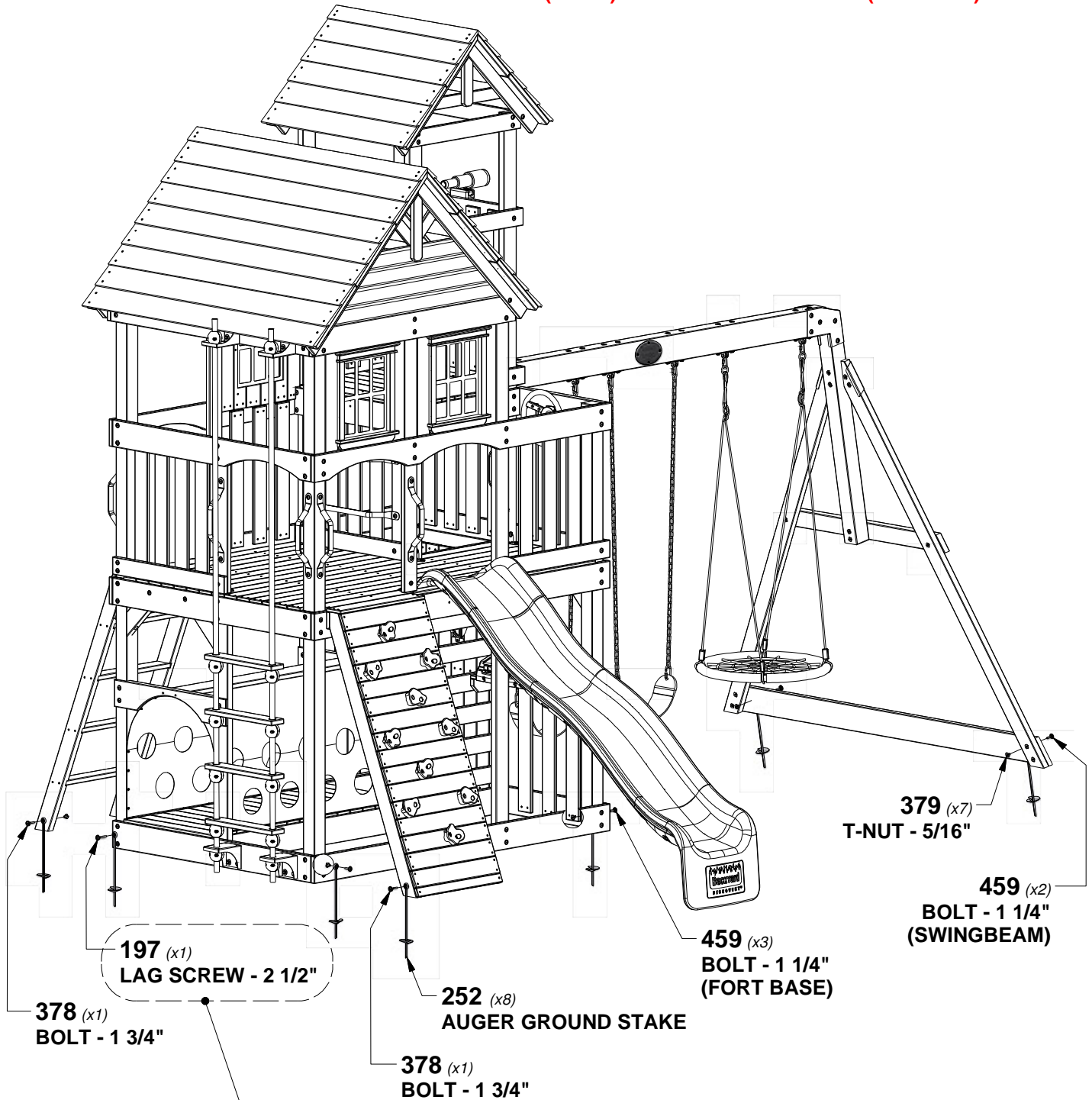

**NOTE:**  
DRILL A 3/16" (5mm) HOLE FOR (197 LAG SCREW).